

WORKING  
DRAFT

X3T10  
1048D

Revision 9.0  
November 12, 1996

## INFORMATION TECHNOLOGY - SCSI-3 Multimedia Commands

This is a draft proposed American National Standard of Accredited Standards Committee X3. As such this is not a completed standard. The X3T10 Technical Committee may modify this document as a result of comments received during public review and its approval as a standard. Use of the information contained herein is at your own risk.

Permission is granted to members of X3, its technical committees, and their associated task groups to reproduce this document for the purposes of X3 standardization activities without further permission, provided this notice is included. All other rights are reserved. Any commercial or for-profit replication or republication is prohibited.

MMC Technical Editor:

Ron Roberts  
SIERRA-PAC TECHNOLOGY  
PO Box 2389  
Shingle Springs, CA 95682  
Tel. (916) 677-5714  
Fax (916) 677-1218  
E-mail: rkroberts@aol.com

Reference number  
ISO/IEC \*\*\*\*\* :199X  
ANSI X3.\*\*\* :199X  
Printed Nov. 12 , 1996

## POINTS OF CONTACT:

### X3T10 Chair

John B. Lohmeyer  
Symbios Logic, Inc.  
4420 ArrowsWest Drive  
Colo. Spgs, CO 80907-3444  
Tel: (719) 533-7560  
Fax: (719) 533-7036  
Email: john.lohmeyer@symbios.com

### X3T10 Vice-Chair

Lawrence J. Lamers  
Adaptec Inc.  
691 S. Milpitas Blvd.  
Milpitas, Ca. 95035  
Telephone: (408) 957-7817  
Facsimile: (408) 957-7193  
Email: ljlammers@aol.com

### X3 Secretariat

X3 Secretariat  
1250 Eye Street, NW Suite 200  
Washington, DC 20005

Telephone: 202-737-8888  
Facsimile: 202-638-4922  
e-mail: X3@itic.nw.dc.us

### SCSI Reflector

Internet address for subscription to the SCSI reflector:  
Internet address for distribution via SCSI reflector:

majordomo@symbios.com  
scsi@symbios.com

### MMC Reflector

Internet address for subscription to the MMC Reflector  
Internet address for distribution via MMC Reflector

majordomo@dt.wdc.com  
mmc@dt.wdc.com

### SCSI Bulletin Board

719-533-7950

### Document Distribution

Global Engineering  
15 Inverness Way East  
Englewood, CO 80112-5704

Telephone: 303-792-2181 or  
800-854-7179  
Facsimile: 303-792-2192

## ABSTRACT

This working draft standard defines the SCSI-3 command set extensions to access multimedia features for all classes of SCSI-3 devices. The applicable clauses of this standard when used in conjunction with the SCSI Primary Commands specification, SCSI-3 Block Commands, and other applicable command set documents pertaining to the subject device class, define the full standard set of commands available for that device in the SCSI-3 environment.

## PATENT STATEMENT

The developers of this standard have requested that holder's of patents that may be required for the implementation of the standard, disclose such patents to the publisher. However neither the developers nor the publisher have undertaken a patent search in order to identify which if any patents may apply to this standard.

No position is taken with respect to the validity of any claim or any patent rights that may have been disclosed. Details of submitted statements may be obtained from the publisher concerning any statement of patents and willingness to grant a license under these rights on reasonable and non-discriminatory terms and conditions to applicants desiring to obtain such a license.

## REVISION HISTORY

Revision 2a - Base document for tracking changes.

Revision 2b - Added Clause 5.0 for CD-R. Updated foreword, added revision history.

Revision 3.0 - Added Commands for CD-R in clause 5, added Annex A (ASC and ASCQ Assignments), Annex F(Functional Requirements), updated CD commands in reference to SFF 8020 rev 2.5, general editing of other clauses.

Revision 4.0 - Added all write commands and reorganized document by command name. Included all known changes and corrections. Added Annex B (Command Listings).

Revision 5.0 - Includes changes to write process commands introduced by Philips, Ricoh, Sony, Yamaha. Also includes changes identified by Toshiba, Mitsumi, and others. All changes were as a result of working group activity. Revisions after this one will contain revision marks.

Revision 6.0 - Includes all updates from ATAPI 2.6, Format CD command, ATAPI annex (D), Blank command changes. Also includes all submitted changes to Rev 4, 5, 5D. Document includes change bars for Rev 5.D changes.

Revision 7.0 - Includes all updates noted at May working group session, except new Format command. ISRC tables revised, Rd TOC/PMA/ATIP revised, all other identified changes included.

Revision 7.0G - Includes changes developed during the June 17 -19th working group session. Also includes new Format Unit command from Philips, new Annex B from HP, comments from Apple, Yamaha, Ricoh, Mitsumi, and Sony. Informative annexes have been moved to Annex N through Annex P. WRITE CD and WRITE CD MSF commands have been removed.

Revision 8.0B - Includes all responses to letter ballot comments. Also includes new ASC, ASCQ tables and references for each command. New clause 2.0 Normative References conforms to X3 guidelines.

## Table of Contents

REVISION HISTORY.....	iii
Foreword.....	xii
Introduction .....	xiii
1. Scope .....	1
2. Normative References.....	3
2.1. Approved references.....	3
2.2. References under development .....	3
2.3. Other references.....	3
3. Definitions, abbreviations and symbols.....	5
3.1. Definitions of terms .....	5
3.2. Abbreviations and symbols.....	7
3.3. Conventions.....	7
3.4. Keywords.....	7
4. CD Devices .....	8
4.1. Model for CD Devices.....	8
4.1.1. CD media organization.....	8
4.1.2. Supported Block Sizes .....	11
4.1.3. CD physical data format .....	11
4.1.3.1. Frame format for audio.....	11
4.1.3.2. Q sub-channel information formats .....	11
4.1.4. CD-ROM Sector Formats.....	15
4.1.5. CD Audio error reporting .....	15
4.1.6. CD ready condition/not ready condition.....	16
4.1.7. CD address reporting formats (MSF bit).....	17
4.1.8. Sensing support for CD-audio commands.....	17
4.1.9. Error reporting .....	18
4.2. Changer Model .....	19
4.2.1. Initialization.....	20
4.2.2. Changer Addressing .....	21
4.2.3. Automatic Load and Unload Operations .....	21
4.2.4. Delayed Disc load operation .....	21
4.2.5. Prevent / Allow processing .....	22
4.2.6. Error Reporting .....	23
5. CD Commands.....	24
5.1. CD Command Listing.....	24
5.1.1. LOAD/UNLOAD CD Command.....	25
5.1.2. MECHANISM STATUS Command .....	27
5.1.3. PAUSE/RESUME Command.....	30
5.1.4. PLAY AUDIO(10) Command.....	31
5.1.5. PLAY AUDIO(12) Command.....	32
5.1.6. PLAY AUDIO MSF Command .....	33
5.1.7. Play CD Command.....	34
5.1.8. READ CD Command .....	36
5.1.8.1. Description of Sub-Channels R-W.....	42
5.1.9. READ CD MSF Command.....	44
5.1.10. READ CD RECORDED CAPACITY Command.....	45
5.1.11. READ HEADER Command .....	47
5.1.12. READ SUB-CHANNEL Command .....	49
5.1.12.1. Sub-Channel Data Header .....	49

5.1.12.2. Sub-Channel Data Format (01h), CD current position .....	50
5.1.12.3. Sub-Channel Data Format (02h), Media Catalogue Number .....	52
5.1.12.4. Sub-Channel Data Format (03h), Track International Standard Recording Code .....	53
5.1.13. READ TOC/PMA/ATIP Command .....	56
5.1.13.1. READ TOC Response parameter list, general definition .....	57
5.1.13.2. TOC/PMA/ATIP Response Data Format 0000b .....	58
5.1.13.3. TOC/PMA/ATIP Response Data Format 0001b .....	59
5.1.13.4. TOC/PMA/ATIP Response Data Format 0010b .....	60
5.1.13.5. TOC/PMA/ATIP Response Data Format 0011b .....	63
.....	63
5.1.13.6. TOC/PMA/ATIP Response Data Format 0100b .....	64
5.1.14. SCAN Command .....	66
5.1.15. SET CD SPEED Command .....	69
5.1.16. STOP PLAY/SCAN Command .....	70
5.2. Parameters for CD devices .....	72
5.2.1. Diagnostic parameters .....	72
5.2.2. Log parameters .....	72
5.2.3. Mode parameters .....	72
5.2.3.1. CD Audio Control parameters .....	75
5.2.3.2. CD device parameters .....	77
5.2.3.3. Read error recovery parameters .....	77
5.2.3.4. CD Capabilities and Mechanical Status Page .....	79
5.2.3.5. Verify error recovery parameters .....	83
6. CD-RECORDABLE/REWRITABLE (CD-R/RW) .....	88
6.1. Write Parameters .....	88
6.1.1. Write Parameters Mode Page .....	88
6.2. CD-R/RW Commands .....	93
6.2.1. CD-R/RW Command Listing .....	93
6.2.2. BLANK Command .....	94
6.2.3. CLOSE TRACK/SESSION Command .....	96
6.2.4. FORMAT UNIT command .....	98
6.2.5. READ BUFFER CAPACITY Command .....	101
6.2.6. READ DISC INFORMATION Command .....	103
6.2.7. READ MASTER CUE Command .....	108
6.2.8. READ TRACK INFORMATION Command .....	110
6.2.9. REPAIR TRACK command .....	116
6.2.10. RESERVE TRACK Command .....	117
6.2.11. SEND CUE SHEET Command .....	119
6.2.11.1. CUE SHEET FORMAT .....	119
6.2.11.2. Information of the absolute disc location .....	120
6.2.11.3. Data Form of Sub-Channel .....	125
6.2.11.4. Absolute Time .....	125
6.2.11.5. Session Format .....	125
6.2.11.6. Pre-gap .....	126
6.2.11.7. Post-gap .....	126
6.2.11.8. Catalog Number .....	126
6.2.11.9. ISRC .....	127
6.2.12. SEND OPC INFORMATION Command .....	128
6.2.13. SYNCHRONIZE CACHE Command .....	130
6.2.14. WRITE Command .....	131
Annex A Additional Sense Codes for CD (normative) .....	135
A.1. Error Reporting .....	135
Annex B ATAPI Compliance (normative) .....	147

B.1. Introduction.....	147
B.2. General .....	147
B.2.1. Terms .....	147
B.2.2. Supported Block Sizes.....	147
B.2.3. CD Audio error reporting.....	147
B.2.4. Multi-Initiator Environment.....	147
B.2.5. Command Packet Padding.....	147
B.3. ATAPI CD Commands.....	148
B.4. Parameters for CD devices.....	150
B.4.1. Mode parameters.....	150
B.4.2. CD Audio Control parameters.....	150
B.4.3. Write Parameters Mode Page.....	150
Annex C Command Play/Scan Operation (normative).....	151
Annex N Command Listings (Informative).....	152
Annex O - Functional Requirements for CD-R (Informative).....	156
O.1. - INTRODUCTION.....	156
O.1.1. - GENERAL .....	156
O.2. - Disc Definition .....	156
O.3. - Status Definitions.....	157
O.3.1. - Track Definitions.....	157
O.3.1.1. - Static track definitions.....	157
O.3.1.2. - Dynamic Track definitions.....	157
O.3.2. - Session Definitions.....	157
O.3.2.1. - Static Session definition.....	157
O.3.2.2. - Session State Transitions.....	158
O.3.3. - Disc Status Definitions .....	158
O.3.3.1. - Static Disc Definitions.....	158
O.3.3.2. - Disc State Transitions .....	158
O.3.4. - Test for Writable Disc.....	159
O.4. - Write Process.....	160
O.5. - Empty Disc.....	161
O.6. - Session Status.....	162
O.7. - RESERVE TRACK.....	163
O.8. - Write a Track .....	164
O.9. - Write a Packet.....	166
O.10. - Complete Incremental Track .....	168
O.11. - Write Raw .....	169
O.12. - Complete Session .....	170
Annex P - SAMPLES OF CUE SHEETS (Informative).....	171

## List of Tables

Table 1 - Example of Mixed Mode CD Disc Layout.....	9
Table 2 - Block Sizes for Read.....	11
Table 3 - ISRC 6 bit character codes (in hexadecimal).....	14
Table 4 - Not Ready Error Reporting (by command).....	16
Table 5 - MSF Address format .....	17
Table 6 - Sense key responses for error reporting.....	18
Table 7 - Commands that may cause delayed loads to occur.....	21
Table 8 - Commands that will cause delayed loads to occur .....	22
Table 9 - Commands that should not cause delayed loads to occur .....	22
Table 10 - Error Conditions and Sense Keys for Changer Mechanisms.....	23
Table 11 - Multimedia Commands Specific to CD Devices.....	24
Table 12 - LOAD/UNLOAD CD command .....	25
Table 13 - Load/Unload Operations.....	25
Table 14 - Recommended errors for Load/Unload CD operation.....	26
Table 15 - MECHANISM STATUS Command Descriptor Block .....	27
Table 16 - Mechanism Status Parameter List.....	28
Table 17 - Mechanism Status Header.....	28
Table 18 - Changer State Field.....	28
Table 19 - CD Mechanism State Field .....	29
Table 20 - Slot Table Response Format.....	29
Table 21 - Recommended errors for Mechanism Status command .....	29
Table 22 - PAUSE/RESUME Command Descriptor Block .....	30
Table 23 - Recommended errors for PAUSE/RESUME command .....	30
Table 24 - PLAY AUDIO(10) Command Descriptor Block .....	31
Table 25 - Recommended errors for PLAY AUDIO(10) Command .....	31
Table 26 - PLAY AUDIO(12) Command Descriptor Block .....	32
Table 27 - Recommended errors for PLAY AUDIO(12) Command .....	32
Table 28 - PLAY AUDIO MSF Command Descriptor Block .....	33
Table 29 - Recommended errors for PLAY AUDIO MSF Command .....	33
Table 30 - PLAY CD Command Descriptor Block.....	34
Table 31 - Expected Sector type field bit definitions .....	34
Table 32 - PLAY CD, Field definition .....	35
Table 33 - Recommended errors PLAY CD Command.....	35
Table 34 - READ CD Command Descriptor Block .....	36
Table 35 - Header Code field definition .....	37
Table 36 - READ CD, Error field definition .....	37
Table 37 - READ CD, Sub-channel Data Selection Field definition.....	38
Table 38 - Formatted Q sub-channel response data.....	38
Table 39 - Number of Bytes Returned Based on Data Selection Field.....	39
Table 40 - Recommended errors for READ CD command.....	40
Table 41 - CD-DA (Digital Audio) Data Block Format.....	40
Table 42 - P-W RAW data format .....	40
Table 43 - P-W Data de-interleaved and error corrected .....	41
Table 44 - Sub-channel R-W; Allowed mode/item combinations .....	43
Table 45 - READ CD MSF Command Descriptor Block.....	44
Table 46 - Recommended errors for READ CD MSF Command.....	44
Table 47 - READ CD RECORDED CAPACITY Command Descriptor Block.....	45
Table 48 - READ CD RECORDED CAPACITY data format .....	45
Table 49 - Recommended errors for READ CD RECORDED CAPACITY Command.....	46
Table 50 - READ HEADER Command Descriptor Block.....	47
Table 51 - READ HEADER LBA data format .....	47
Table 52 - CD Data Mode field.....	48
Table 53 - READ HEADER MSF data format.....	48

Table 54 - Recommended errors for READ HEADER command.....	48
Table 55 - READ SUB-CHANNEL Command Descriptor Block.....	49
Table 56 - Sub-channel parameter list codes.....	49
Table 57 - Sub-Q Channel Data Header Format.....	50
Table 58 - Audio status codes.....	50
Table 59 - CD current position data format.....	50
Table 60 - ADR Q sub-channel field.....	51
Table 61 - Q sub-channel control field.....	51
Table 62 - Media Catalogue Number data format.....	52
Table 63 - MCN Format of Data Returned.....	52
Table 64 - Track International Standard Recording Code data format.....	53
Table 65 - ISRC Format of Data Returned.....	54
Table 66 - Recommended errors for READ SUB-CHANNEL command.....	55
Table 67 - READ TOC/PMA/ATIP Command Descriptor Block.....	56
Table 68 - Format Field.....	56
Table 69 - READ TOC/PMA/ATIP parameter list, general definition.....	57
Table 70 - READ TOC/PMA/ATIP response data (Format = 0000b).....	58
Table 71 - READ TOC/PMA/ATIP response data (Format = 0001b).....	59
Table 72 - READ TOC/PMA/ATIP response data (Format = 0010b).....	60
Table 73 - TOC Track Descriptor Format, Q sub-channel.....	61
Table 74 - POINT Field.....	61
Table 75 - Disc Type Byte Format.....	62
Table 76 - READ TOC/PMA/ATIP response data (Format = 0011b).....	63
Table 77 - READ TOC/PMA/ATIP response data (Format = 0100b).....	64
Table 78 - Lowest CLV Recording Speeds.....	65
Table 79 - Highest CLV Recording Speeds.....	65
Table 80 - Recommended errors for READ TOC/PMA/ATIP Command.....	65
Table 81 - SCAN Command Descriptor Block.....	66
Table 82 - Type field bit definitions.....	67
Table 83 - Scan starting address field format-logical blocks.....	67
Table 84 - Scan Starting Address format - MIN, SEC, FRAME format.....	67
Table 85 - Scan Starting Address Format-Track Number (TNO).....	67
Table 86 - Recommended errors for SCAN operation.....	68
Table 87 - SET CD SPEED Command Descriptor Block.....	69
Table 88 - Recommended errors for SET CD SPEED Command.....	69
Table 89 - STOP PLAY/SCAN Command Descriptor Block.....	70
Table 90 - Recommended errors for STOP PLAY/SCAN Command.....	70
Table 91 - Diagnostic page codes.....	72
Table 92 - Log page codes.....	72
Table 93 - CD medium type codes.....	73
Table 94 - CD device specific parameter.....	73
Table 95 - CD Density codes.....	73
Table 96 - Mode page codes.....	74
Table 97 - CD Audio Control parameters page.....	75
Table 98 - Output port channel selection.....	76
Table 99 - CD parameters page.....	77
Table 100 - Inactivity timer multiplier values.....	77
Table 101 - Read error recovery parameters page.....	78
Table 102 - Error Recovery Parameter Bit Settings.....	78
Table 103 - CD Capabilities and Mechanical Status Page.....	79
Table 104 - Loading Mechanism Type.....	81
Table 105 - Data Rate Examples.....	82
Table 106 - Verify error recovery parameters page.....	83
Table 107 - CD Devices, error recovery description.....	84



Table 108 - Write Parameters Mode Page.....	89
Table 109 - Write Type Field.....	90
Table 110 - Multi-session Field Definition.....	90
Table 111 - Data Block Type Codes.....	91
Table 112 - Session Format Codes.....	92
Table 113 - Commands Specific to CD-R/RW Devices.....	93
Table 114 - BLANK Command Descriptor Block.....	94
Table 115 - Blanking Types.....	95
Table 116 - Recommended errors for BLANK Command.....	95
Table 117 - CLOSE TRACK/SESSION Command Descriptor Block.....	96
Table 118 - Session and Track Bits Definitions.....	96
Table 119 - Recommended errors for CLOSE TRACK/SESSION Command.....	97
Table 120 - Format Unit Command.....	98
Table 121 - Format Unit Parameter List.....	98
Table 122 - Format List Header.....	98
Table 123 - Initialization Descriptor.....	99
Table 124 - CD-RW Format Descriptor.....	99
Table 125 - Recommended errors for FORMAT UNIT Command.....	100
Table 126 - READ BUFFER CAPACITY Command Descriptor Block.....	101
Table 127 - READ BUFFER CAPACITY data.....	101
Table 128 - Recommended errors for READ BUFFER CAPACITY Command.....	102
Table 129 - READ DISC INFORMATION Command Descriptor Block.....	103
Table 130 - Disc Information Block.....	104
Table 131 - Disc Status.....	105
Table 132 - State of Last Session.....	105
Table 133 - Disc Type Field - PMA.....	106
Table 134 - OPC Table Entry.....	107
Table 135 - Recommended errors for READ DISC INFORMATION Command.....	107
Table 136 - READ MASTER CUE Command Descriptor Block.....	108
Table 137 - Sheet Number Values.....	108
Table 138 - Master CD response data format.....	108
Table 139 - Recommended errors for READ MASTER CUE Command.....	109
Table 140 - READ TRACK INFORMATION Command Descriptor Block.....	110
Table 141 - Track Number/LBA Field definition.....	110
Table 142 - Track Information Block.....	111
Table 143 - Write Parameter Restrictions due to Track State.....	112
Table 144 - Track Status Indications.....	113
Table 145 - Data Mode.....	113
Table 146 - Next Writable Address Definition.....	114
Table 147 - Recommended errors for READ TRACK INFORMATION Command.....	115
Table 148 - REPAIR TRACK Command Descriptor Block.....	116
Table 149 - Recommended errors for REPAIR TRACK Command.....	116
Table 150 - RESERVE TRACK Command Descriptor Block.....	117
Table 151 - Track reservation sizing.....	117
Table 152 - Recommended errors for RESERVE TRACK Command.....	118
Table 153 - SEND CUE SHEET Command Descriptor Block.....	119
Table 154 - Cue Sheet format.....	119
Table 155 - Sample CUE SHEET.....	120
Table 156 - Cue Sheet Data.....	121
Table 157 - CTL/ADR byte.....	121
Table 158 - Control Field.....	121
Table 159 - ADR Field.....	122
Table 160 - Data Form Byte.....	122
Table 161 - SCMS Byte.....	122

Table 162 - CD-DA Data format (1 Sample) .....	123
Table 163 - Data Form of Sub-channel .....	125
Table 164 - Catalog Number (N1..N13).....	126
Table 165 - ISRC (I1..I12).....	127
Table 166 - Recommended Sense Key, ASC and ASCQ SEND CUE SHEET Command.....	127
Table 167 - SEND OPC INFORMATION Command Descriptor Block .....	128
Table 168 - SEND OPC INFORMATION Paramter List .....	128
Table 169 - Recommended errors for SEND OPC INFORMATION Command .....	129
Table 170 - SYNCHRONIZE CACHE Command .....	130
Table 171 - Recommended errors for SYNCHRONIZE CACHE Command .....	130
Table 172 - WRITE command.....	131
Table 173- LBA to MSF translation .....	132
Table 174 - Recommended errors for WRITE Command.....	134
Table A.1 - CD Device Sense Key, ASC and ASCQ Assignments .....	136
Table A.2 - CD General Errors.....	142
Table A.3 - CD Media Access Errors.....	144
Table A.4 - CD Write Errors .....	146
Table A.5 - CD Fixation Errors .....	146
Table B.1. - ATAPI CD Commands .....	148
Table B.2 - Mode page codes.....	150
Table C.1 - Commands That Will Stop a Play or Scan Operation .....	151
Table N.1 - Multimedia Commands - Alphabetically .....	152
Table N.2 - Multimedia Commands - by OpCode .....	153
Table N.3 - Commands Common to all SCSI Devices .....	154
Table N.4 (cont.) - Commands Common to all SCSI Devices .....	155
Table P.1 - Session At Once Cue sheet Sample 1 (CD-DA) .....	171
Table P.2 - Cue Sheet Sample 2 (CD-ROM mode 1).....	172
Table P.3 - Cue sheet Sample 3 (CD-I).....	172
Table P.4 - Cue sheet Sample 4 (CD-ROM XA) .....	172
Table P.5 - Cue sheet Sample 5 (CD-ROM mix mode) .....	172
Table P.6 - Cue sheet Sample 6 (CDDA start track = 5) .....	173

## List of Figures

Figure 1 - Scope of SCSI-3 Standards.....	2
Figure 2 - Small Frame layout and definition.....	11
Figure 3 - Q sub-channel Information Block.....	12
Figure 4 - Q sub-channel Mode-1 Format recorded in lead-in.....	12
Figure 5 - Q sub-channel Mode-1 Format recorded in Program Area and lead-out.....	12
Figure 6 - Q sub-channel Mode-2 Format.....	13
Figure 7 - Q sub-channel, Mode-3 Format.....	14
Figure 8 - CD-ROM Sector Formats.....	15
Figure 9 - Media Changer Mechanism Model.....	19
Figure 10 - Changer State Diagram.....	20
Figure 11 - Read CD Sub-Channel, R-W (100b).....	42
Figure 12 - Stop Play/Play Audio/Audio Scan/Pause/Resume Sequencing.....	71
Figure 13 - CD (CD-DA).....	123
Figure 14 - CD-ROM mode 1.....	123
Figure 15 - CD-ROM XA, CD-I.....	124
Figure 16 - CD-ROM Mode 2.....	124
Figure 17 - Location of Sub-channel Data.....	125
Figure O.1 - Disc Area Definitions.....	156
Figure O.2 - Test for Writable CD-R Disc.....	159
Figure O.3 - Overall Write Process.....	160
Figure O.4 - Blank Disc.....	161
Figure O.5 - Session Status.....	162
Figure O.6 - RESERVE TRACK.....	163
Figure O.7 - Write Track at Once.....	165
Figure O.8 - Write Packet.....	166
Figure O.9 - Complete Incremental Track.....	168
Figure O.10 - Write Session At Once.....	169
Figure O.11 - Complete Session.....	170

## Foreword

The SCSI-3 Multimedia Commands standard at present consists of six clauses and three annexes. In addition there are three informative annexes. This standard describes the CD device class (common to all CD devices) in clause 4 and the CD-R/RW device class (Write Once devices) in clause 5. All other clauses will be applicable to any device class described in this document unless explicitly stated otherwise.

Clause 1 is the scope.

Clause 2 enumerates the normative references that apply to this standard.

Clause 3 describes the definitions, symbols and abbreviations used in this standard.

Clause 4 describes the following multimedia extensions for all CD device classes:

- overview (i.e., model of CD) and the conventions used in this standard.
- the various parameters and mode pages used in control of device features and error recovery.
- numerous diagnostic, log and mode parameters for configuration, monitoring and control of CD devices.

Clause 5 describes the following multimedia extensions for a CD device.

- commands applicable to the CD class of devices under SCSI-3.

Clause 6 describes the following multimedia extensions for a CD-R/RW device:

- various parameters and mode pages unique to CD-R/RW devices.
- commands applicable to the CD-R/RW device class under SCSI-3.

Annex A describes additional sense codes for CD devices (normative).

Annex B contains a requirements for ATAPI Compliance (normative).

Annex C contains listing of commands and behavior during Play/Scan Operation (normative).

Annex N contains listings of commands used by CD device classes (informative).

Annex O is an informative annex that describes the Functional Requirements for a recordable CD (CD-R/RW) and is an overview and architectural model for writing to a CD-R device (informative).

Annex P contains sample Cue sheets that may be passed to the device (informative).

Other industry standards were reviewed and consulted by the committee in the development of this standard. These standards and specifications are directly related to CD-ROMs, CD-R devices, and other optical devices. The documents included Compact Disc CD-DA (RED BOOK), Compact Disc CD-ROM (YELLOW BOOK), Compact Disc CD-R, Recordable CD Systems (ORANGE BOOKS Part II and Part III), Compact Disc CD-XA, Compact Disc CD-DA Enhanced Audio CD Ver 1.0, and Multi-Session Compact Disc. Where practical, this standard is consistent with the accepted industry standards that were consulted.

## Introduction

The SCSI-3 command set is defined independently of the physical and signaling protocol to enable its implementation in a number of environments. The X3T10 technical committee has seen the need to address the unique requirements for the SCSI support of multimedia in this document. This provides a central reference for both multimedia implementors and implementors of the SCSI-3 standard.

The physical transports currently being defined for SCSI-3 command sets include SCSI Parallel Interface (SPI), Serial Storage Architecture (SSA), Fibre Channel FC-4, and IEEE 1394 described in SCSI-3 Serial Bus Protocol (SBP). Implementors may assure architectural coherency across multiple environments by implementing the applicable clauses contained within the SCSI-3 Architectural Model Specification (X3.270-199x0)(SAM).

It is anticipated that this standard may be updated periodically in response to technological advances.

All standard updates are subject to the X3 policies and procedures accredited by ANSI and involve a public review period and balloting process.

With any technical document there may arise questions of interpretation as new products are implemented. The X3 Committee has established procedures to issue technical opinions concerning the standards developed by the X3 organization. These procedures may result in SCSI Technical Information Bulletins being published by X3.

These Bulletins, while reflecting the opinion of the Technical Committee that developed the standard, are intended solely as supplementary information to other users of the standard. This standard, X3T10/1048D, as approved through the publication and voting procedures of the American National Standards Institute, is not altered by these bulletins. Any subsequent revision to this draft standard may or may not reflect the contents of these Technical Information Bulletins.

Current X3 practice is to make Technical Information Bulletins available through:

Global Engineering  
15 Inverness Way East  
Englewood, CO 80112-5704

Telephone: 303-792-2181 or  
800-854-7179  
Facsimile: 303-792-2192

## 1. Scope

This standard defines the multimedia command set extensions for all classes of SCSI devices. The commands specified within this standard define standard access and control to those features of the device that are used in multimedia applications (audio, video, animation). The entire standard command set available for a subject device shall be fully specified by the clause/clauses of this standard pertaining to that device, the applicable clauses of SCSI-3 Primary Commands, and any additional command set standards pertaining to the subject device as documented in the SCSI-3 family of standard.

The SCSI-3 command set and these extensions are transport independent and may be implemented across a wide variety of environments for which a SCSI-3 command mapping and delivery vehicle has been defined. To date these include Fibre Channel, SCSI Parallel Interface, High Performance Serial Bus, and Serial Storage Architecture .

The objective of this command set is to provide for the following:

- 1) To provide a definition of the command format and functionality independent of delivery, protocol/signaling or transport mechanism. Architectural constraints regarding command function across the various transports are addressed in the SCSI-3 Architectural Model and the document specific to the physical transport.
- 2) To provide standardized access to common features of SCSI-3 devices employed in multimedia applications.
- 3) To provide host computer software/firmware with device independence within a class of devices. Thus, different tape drives, optical media drives, and other devices can be added to host computers without requiring modifications to generic system hardware and software. Provision is made for the addition of special features and functions through the use of vendor-specific options. Reserved opcodes are provided for future standardization.
- 4) To provide compatibility such that properly conforming SCSI-2 devices may inter-operate with SCSI-3 devices given that the systems engineering is correctly done. SCSI-3 protocol extensions are designed to be permissive of rejections by conforming SCSI-2 devices and thus allow the SCSI-2 device to continue operation without requiring the use of the extension.

Figure 1 is intended to show the relationship of this document to other SCSI-3 standards. The figure is not intended to imply a relationship such as a hierarchy, protocol stack, or system architecture. It indicates the applicability of a standard to the implementation of a given transport.

For example:

SPC and SAM and the SCSI-3 command set standards are applicable to all protocols.  
SIP, SSP, FCP, and SBP are linked to specific protocols designed to be applied only to the service delivery subsystem directly below them.

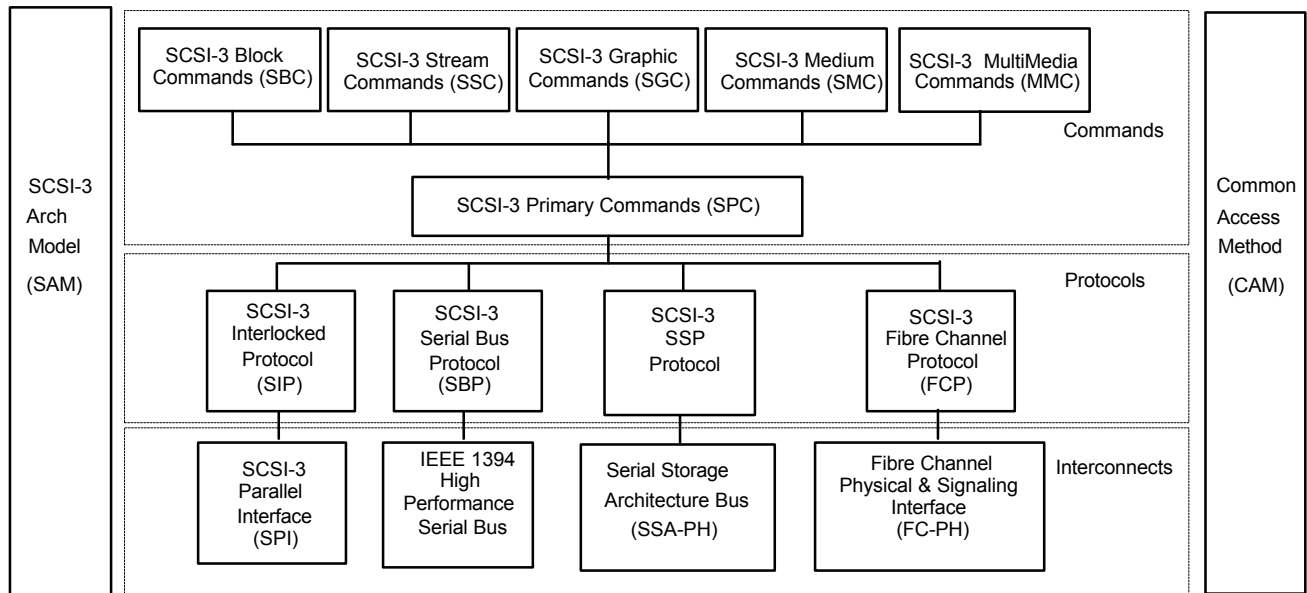

Figure 1 - Scope of SCSI-3 Standards

The term SCSI is used wherever it is not necessary to distinguish between the versions of SCSI. The “Small Computer System Interface - 2 (X3.131-1994) is referred to herein as SCSI-2.

The term SCSI-3 refers collectively to the following documents:

SCSI-3 Parallel Interface (X3T10/855D)(X3.253)

SCSI-3 Interlocked Protocol (X3T10/856D)

SCSI-3 Fiber Channel Protocol (X3T10/993D)(X3.269)

SCSI-3 Serial Bus Protocol (X3T10/992D)(X3.268)

SCSI-3 Architecture Model (X3T10/994D)(X3.270)

SCSI-3 Primary Commands (X3T10/995D)

SCSI-3 Block Commands (X3T10/996D)

SCSI-3 Stream Commands (X3T10/997D)

SCSI-3 Graphic Commands (X3T10/998D)

SCSI-3 Medium Changer Commands (X3T10/999D)

SCSI-3 Controller Commands (X3T10/1047D)(X3.276)

SCSI-3 Multimedia Command Set (X3T10/1048D)

SCSI-3 Fast-20 Parallel Interface (X3T10/1071D)(X3.277)

Serial Storage Architecture SCSI-3 Protocol (X3T10/1051D)

Serial Storage Architecture Physical Layer 1 (X3T10/1145D)

Serial Storage Architecture Physical Layer 2 (X3T10/1146D)

Serial Storage Architecture Transport Layer 2 (X3T10/1147D)

## 2. Normative References

The following standards contain provisions which, through reference in the text, constitute provisions of this standard. At the time of publication, the editions indicated were valid. All standards are subject to revision, and parties to agreements based on this standard are encouraged to investigate the possibility of applying the most recent editions of the standards listed below.

Copies of the following documents can be obtained from ANSI: Approved ANSI standards, approved and draft international and regional standards (ISO, IEC, CEN/CENELEC, ITUT), and approved and draft foreign standards (including BSI, JIS, and DIN). For further information, contact ANSI Customer Service Department at 212-642-4900 (phone), 212-302-1286 (fax) or via the World Wide Web at <http://www.ansi.org>.

Additional availability contact information is provided below as needed.

### 2.1. Approved references

The following approved ANSI standards, approved international and regional standards (ISO, IEC, CEN/CENELEC, ITUT), may be obtained from the international and regional organizations who control them.

ISO/IEC 10149, Information Technology-Data Interchange on Read-only 120 mm Optical Data Discs (CD-ROM).

IEC 908:1987, Compact Disc Digital Audio System

Members of IEC and ISO maintain registers of currently valid International Standards.

### 2.2. References under development

At the time of publication, the following referenced standards were still under development. For information on the current status of the document, or regarding availability, contact the relevant standards body or other organization as indicated.

SCSI-3 Parallel Interface (SPI) [X3.253]  
SCSI-3 Interlocked Protocol (SIP) [X3T10/0856-D]  
SCSI-3 Serial Bus Protocol (SBP) [X3.268]  
SCSI-3 Architecture Model (SAM) [X3.270]  
SCSI-3 Primary Commands (SPC) [X3T10/0995-D]  
SCSI-3 Block Commands (SBC) [X3T10/0996-D]  
SCSI-3 Medium Changer Commands (SMC) [X3T10/0999-D]

For more information on the current status of the above documents, contact (Secretariat). To obtain copies of these documents, contact Global Engineering or (Secretariat).

### 2.3. Other references

The following standards and specification were also consulted.

Compact Disc Digital Audio (CD-DA), specified in the System Description Compact Disc Digital Audio ("Red Book"), N.V. Philips and Sony Corporation. See also IEC 908:1987, Compact Disc Digital Audio System

Compact Disc Read Only Memory (CD-ROM), specified in the System Description Compact Disc Read Only Memory ("Yellow Book"), N.V. Philips and Sony Corporation. See also ISO/IEC 10149, Information Technology-Data Interchange on Read-only 120 mm Optical Data Discs (CD-ROM).

Compact Disc Interactive (CD-I), specified in the CD-I Full Functional Specification ("Green Book"), N.V. Philips and Sony Corporation.

Compact Disc Read Only Memory eXtended Architecture (CD-ROM XA), specified in the System Description CD-ROM XA, N.V. Philips and Sony Corporation.



Compact Disc Write Once (CD-WO), specified in the System Description Recordable Compact Disc Systems, part II: CD-WO (Orange Book part II), N.V. Philips and Sony Corporation

Compact Disc Rewritable (CD-RW), specified in the System Description Recordable Compact Disc Systems, part III: CD-RW (Orange Book part III), N.V. Philips and Sony Corporation

Multisession Compact Disc, specified in the Multisession Compact Disc Specification, N.V. Philips and Sony Corporation.

### 3. Definitions, abbreviations and symbols

Certain words and terms used in this standard have a specific meaning beyond the normal English meaning. These words and terms are defined either in the glossary or in the text where they first appear. Lower case is used for words having the normal English meaning.

Fields containing only one bit are referred to as the “named” bit instead of the “named” field.

#### 3.1. Definitions of terms

- 3.1.1. absolute MSF field - See MSF address definition.
- 3.1.2. Appendable Disc - A disc in which the last session has a pointer to the next possible session.
- 3.1.3. ATIP - Absolute Time In Pre-groove
- 3.1.4. bcd - binary coded decimal - The number system used on the physical CD media. Numbers that use this notation have the 'bcd' suffix attached. A byte has two four-bit values each of which can have a value from 0 to 9. The maximum value is 99 bcd (99 decimal).
- 3.1.5. bootable CD - a CD that is capable of providing boot records.
- 3.1.6. Complete Session - A session that contains a written lead-in and lead-out.
- 3.1.7. CD-DA - Compact Disc-Digital Audio - The standard for storing digital audio information. See IEC 908:1987.
- 3.1.8. CD - Compact Disc - Generic class of all devices that conform to this standard.
- 3.1.9. CD-ROM - Compact Disc - Read Only Memory - A standard for storing digitized audio and digital data. CD-ROM is used to describe media with digital data rather than discs that encode audio only.
- 3.1.10. CD control field - A four bit field in the Q sub-channel data indicating the type of information encoded on the current track. Indicates audio versus data and the type of audio encoding, etc. The control field is also found in the Table of Contents entries.
- 3.1.11. CD data mode - A byte in the header of CD data sectors. This indicates if data is present and if layered error correction information is present.
- 3.1.12. CD Rewritable (CD-RW) - an overwritable CD system.
- 3.1.13. CD Recordable (CD-R) - a write once CD system.
- 3.1.14. CD R/E - either a CD-R, CD-RW, or both.
- 3.1.15. CIRC - Cross Interleaved Reed-Solomon Code - The error detection and correction technique used on a CD. The CIRC bytes are present in all CD modes. The error correction procedure which uses the CIRC bytes is referred to as the CIRC based algorithm.
- 3.1.16. EAN - European Article Number - Controlled by the EAN Council located at Rue des Colonies, 54-BTE8, 1000 Brussels, Belgium.
- 3.1.17. Fixed Packet Track - a track that contains a TDB indicating that the track is a fixed track, and has user packets of a fixed size specified in the TDB.
- 3.1.18. frame - A sector on CD media. Also the F field unit of a MSF CD address. The smallest addressable unit in the main channel.
- 3.1.19. hold track state - When a CD device enters the hold track state the optical pick-up is maintained at an approximately constant radial position on the media.
- 3.1.20. Incomplete Session - A session without lead-in and lead-out written.
- 3.1.21. index - An index is a subdivision of a CD track.

- 3.1.22. lead-in - The area that contains the TOC data and precedes each program area. The main channel in the lead-in area contains audio or data null information. This area is coded as track zero. The Q sub-channel in this area is coded with the Table of Contents information.
- 3.1.23. lead-out - The area that follows each program area. The main channel in the lead-out area contains audio or data null information. This area is coded as track AA h. The READ CD CAPACITY data is the first logical block address of this area minus one.
- 3.1.24. L-EC - layered error correction - The second level of error correction used on CD data.
- 3.1.25. Logical Block - A CD sector.
- 3.1.26. MSF address - (Minute/Second/Frame) The physical address, expressed as a sector count relative to either the beginning of the medium (absolute) or to the beginning of the current track (relative). As defined by the CD standards, each F field unit is one sector; each S field unit is 75 F field units; each M field unit is 60 S field units. Valid contents of F fields are binary values from 0 through 74. Valid contents of S fields are binary values from 0 through 59. Valid contents of M fields are binary values from 0 through 74.
- 3.1.27. output port - A means for connecting to data ports other than the Initiator interface.
- 3.1.28. OPC- Optimum Power Calibration - a procedure performed by the device to calibrate laser power. Values from this calibration are used for subsequent write operation.
- 3.1.29. Packet - a set of recorded link, run-in, data, and run-out blocks.

Typical packet:

Link Block	Run-in Block 1	Run-in Block 2	Run-in Block 3	Run-in Block 4	Data Blocks	Run-out Block 1	Run-out Block 2
------------	----------------	----------------	----------------	----------------	-------------	-----------------	-----------------

- 3.1.30. Packet Size - is the number of Data Blocks in the packet.
- 3.1.31. Packet Track - a track written as a concatenation of a pre-gap, written as one or two packets, and some non-zero number of user packets.
- 3.1.32. post-gap - A transition area at the end of a data track.
- 3.1.33. pre-gap - A transition area at the beginning of a data track.
- 3.1.34. Program Area - contains the user data.
- 3.1.35. Program Memory Area (PMA) - Contains information about the recordings on a writable disc.
- 3.1.36. relative MSF field - See MSF address definition.
- 3.1.37. sector - is a unit addressed by a frame.
- 3.1.38. Session - A contiguous area of a Disc that contains a lead-in, a Program Area (PA), and a lead-out.
- 3.1.39. small frame - 1/98 of a frame, see sub-clause 4.1.3.
- 3.1.40. sub-channel - CD media have a main channel and a sub-channel. The sub-channel area has eight parts called P, Q, R, S, T, U, V, and W. The Q sub-channel contains information useful to the controller and drive, such as the control field and MSF addresses. The data rate of each sub-channel (P, Q, etc.) is 1/192nd of that of the main channel.
- 3.1.41. Table of Contents (TOC) - The TOC has information on the type of session and the starting address of the tracks. This information is encoded in the Q sub-channel in the lead-in area.
- 3.1.42. Track Descriptor Block (TDB) - Contains information on the attributes of the current track.
- 3.1.43. track - A logical sub-division of the CD media.
- 3.1.44. Track at Once - When a track, including its pre-gap, is written as a single packet.
- 3.1.45. track relative logical address - The value used to address logical blocks relative to the beginning of a track.

- 3.1.46. transition area - Sectors at the beginning or end of tracks e.g. Pause Area, Pre-Gap, lead-out, Post -Gap.
- 3.1.47. UPC - Uniform Product Code - Controlled by the UPC Council, located at 8163 Old Yankee Road, Suite J, Dayton, Ohio 45459.
- 3.1.48. user packet - a packet that contains only user data blocks as the data blocks. User data blocks consist of data transferred to the device during a write command.
- 3.1.49. Writable Disc - A disc that is blank, appendable, or contains an incomplete session.
- 3.1.50. Yellow book - ISO/IEC 10149, Information Technology-Data Interchange on Read-only 120 mm Optical Data Discs (CD-ROM).

### 3.2. Abbreviations and symbols

Numbers that are not immediately followed by lowercase “b,” “h,” or “bcd” are decimal values.

Numbers immediately followed by lowercase “b” (xxb) are binary values.

Numbers immediately followed by lowercase “h” (xxh) are hexadecimal values.

Numbers immediately followed by lowercase “bcd” (xxbcd) are binary coded decimal values.

### 3.3. Conventions

Various conventions are used through-out this standard and are identified in this sub-clause.

- 3.3.1. Recommended error code tables defined within each command sub-clause uses the following:

Errors shown in mixed case indicate all errors in that class are valid.

Errors shown in uppercase refer to the identified specific error condition.

### 3.4. Keywords

Several keywords are used to differentiate between levels of requirements and options, as listed below.

- 3.4.1. expected - A keyword used to describe the behavior of the hardware or software in the design models assumed by this standard. Other hardware and software design models may also be implemented.
- 3.4.2. may - A keyword that indicates flexibility of choice with no implied preference.
- 3.4.3. shall - A keyword indicating a mandatory requirement. Designers are required to implement all such mandatory requirements to ensure interpretability with other standard conforming products.
- 3.4.4. should - A keyword indicating flexibility of choice with a strongly preferred alternative. Equivalent to the phrase “it is recommended.”
- 3.4.5. obsolete - A keyword indicating items that were defined in prior SCSI standards but have been removed from this standard.
- 3.4.6. mandatory - A keyword indicating items required to be implemented as defined by this standard.
- 3.4.7. optional - A keyword that describes features which are not required to be implemented as defined by this standard. However, if any optional feature defined by the standard is implemented, it shall be implemented as defined by the standard.
- 3.4.8. reserved - A keyword referring to bits, bytes, words, fields and code values that are set aside for future standardization. Their use and interpretation may be specified by future extensions to this or other standards. A reserved bit, byte, word, or field shall be set to zero, or in accordance with future extension to this standard. The recipient shall not check reserved bits, bytes, words or fields. Receipt of reserved code values in defined fields shall be treated as an error.

## 4. CD Devices

### 4.1. Model for CD Devices

CD devices permit reading data from a removable rotating media. Data transfer can begin with any of the consecutively numbered logical blocks. Some CD devices support a separate information stream (e.g. audio and/or video but referred to as audio in this clause) transmitted via a connection other than the SCSI Bus. This device type defines commands for controlling these other information streams.

#### 4.1.1. CD media organization

The formats written on the CD and CD-DA (Digital Audio) media require special interfacing considerations.

Note: This sub-clause contains a number of terms that have special meanings peculiar to CD technology or that may be unfamiliar to many readers of this standard. The glossary, sub-clause 3.1., defines these terms.

Discs may contain either audio, data or a mixture of the two. Table 1 gives an example of a mixed mode disc to illustrate the relationship between the logical block addresses reported in SCSI and the MSF address encoded on the media.

NOTE: The term frame is used in two different ways in the CD media standard. The intended meaning can only be determined from the context. Whenever possible, this description replaces the larger data unit with the more familiar term sector. The primary exception to this policy is the use of frame when referring to the MSF address. In the MSF context, one frame (F field unit) equals one sector. On a typical two channel CD-DA media, each frame (F field unit) is played in 1/75th of a second.

The physical format defined by the CD media standards provides 2352 bytes per sector. For usual computer data applications, 2048 bytes are used for user data, 12 bytes for a synchronization field, 4 bytes for a sector address tag field and 288 bytes - the auxiliary field - for L-EC (CD data mode 1). In less critical applications, the auxiliary field may also be used for user data (CD data mode 2). The user data portion of a CD sector contains 2048, 2332, 2340, or 2352 bytes.

Table 1 - Example of Mixed Mode CD Disc Layout

Block Description	Logical Address (Decimal)	Track Relative logical address	Absolute M/S/F Address <sup>1</sup>	Track / Index	Track Relative M/S/F Address	Sector Contains Info or Pause	Mode Audio or Data	CD Data Mode <sup>2</sup>
Lead-in Area	---	---	---	0/-	---	---	Audio	---
Pre-gap	---	---	00/00/00	1/0	00/02/00 <sup>7</sup>	Pause	Data	Null
1st Track data	0000 <sup>4</sup>	0	00/02/00 <sup>5</sup>	1/1	00/00/00	Info	Data	L-EC
2nd track data	6000 <sup>4</sup>	0	01/22/00 <sup>5</sup>	2/1	00/00/00	Info	Data	L-EC
	7500	1500	01/42/00	2/2	00/20/00	Info	Data	L-EC
Post gap	9000	3000	02/02/00	2/3	00/40/00	Pause	Data	Null
Pause-silence	9150	-150 <sup>6</sup>	02/04/00	3/0	00/02/00 <sup>7</sup>	Pause	Audio	---
3rd track audio	9300 <sup>8</sup>	0	02/04/00 <sup>9</sup>	3/1	00/00/00	Info	Audio	---
	1400	2250	02/34/00	3/2	00/03/00	Info	Audio	---
4th track audio	21975 <sup>8</sup>	0	04/53/00 <sup>9</sup>	4/1	00/00/00	Info	Audio	---
Pre-gap part 1	30000	-225 <sup>6</sup>	06/40/00	5/0	00/03/00 <sup>7</sup>	Pause	Audio	---
Pre-gap part 2	300075	-150	06/41/00	5/0	00/02/00 <sup>7</sup>	Pause	Data	Null
5th track data	30225	0	06/43/00	5/1	00/00/00	Info	Data	L-EC
Last Information	263999 <sup>10</sup>	233 774	58/39/74	5/1	51/56/74	Info	Data	L-EC
Post-gap	---	233 775	58/40/00	5/2	51/57/00	Pause	Data	Null
Lead-out area	264000 <sup>11</sup>	0	58/42/00	AA/- <sup>13</sup>	00/00/00	Pause	Audio	---

## Notes:

1. Absolute MSF address repeated in the header field of data blocks.
2. The CD data mode is stored in the header of data tracks. This indicates that the block is part of a data pre-gap or post gap (null), that this is a data block using the auxiliary field for L-EC symbols (ECC-CD data mode one), or that this is a data block using the auxiliary field for user data (CD data mode 2.)
3. Table of Contents information is stored in the sub-channel of lead-in area. The lead-in area is coded as track zero. Track zero and the initial 150 sector pre-gap ( or audio pause) are not accessible with logical addressing.
4. Exact value returned by READ TOC/PMA/ATIP Command.
5. Value stored in Table of Contents with zero tolerance.
6. Track relative logical addresses are negative in the pre-gap areas.
7. Track relative MSF value decreases to 0 in the pre-gap areas.
8. Value returned by READ TOC/PMA/ATIP Command plus or minus 75 blocks.
9. Value stored in Table of Contents plus or minus 75 sectors.
10. Minimum value returned by READ CD RECORDED CAPACITY: exact value depends on encoding of this track and the lead-out track and whether this is derived from the TOC data.
11. Value returned by READ TOC/PMA/ATIP Command; exact if lead-out track is encoded as data, or plus or minus 75 blocks if encoded as audio.
12. Value stored in Table of Contents; exact if lead-out track is coded as data, or plus or minus 75 blocks if coded as audio.
13. Lead-out track number field is defined as AAh.

For all CD media, logical block address zero shall be assigned to the block at MSF address 00/02/00.

Logical addressing of CD information may use any logical block length. When the specified logical block length is an exact divisor or integral multiple of the selected number of bytes per CD sector, the device shall map (one to one) the bytes transferred from CD sectors to the bytes of logical blocks. For instance, if 2048 bytes are transferred from each CD sector, and the logical block length is 512 bytes, then each CD sector shall map to exactly four logical blocks. This

standard does not define the mapping of logical block lengths which do not evenly divide or are not exact multiples of the selected number of bytes per CD-ROM sector.

A track may be viewed as a partition of the CD address space. A CD media contains from one to ninety-nine tracks. All information sectors of a track are required to be of the same type (audio or data) and mode. Each change in the type of information on the disc requires a change in track number. A disc containing both audio and data would have at least two tracks, one for audio and one for data.

The tracks of a CD media are numbered consecutively with values between 1 and 99. However, the first information track may have a number greater than 1. Tracks have a minimum length of 300 sectors plus any transition area that is part of a track.

The CD media standards require transition areas between tracks encoded with different types of information. In addition, transition areas may be used at the beginning or end of any track. For audio tracks the transition areas are called pause areas. For data tracks, transition areas are called pre-gap and post-gap areas. See Table 1 for an example. The IEC 908 and ISO/IEC 10149 standards specify minimum time duration for these areas. Maximum time duration's are not specified.

Transition areas are formatted and the logical address continues to increment through transition areas. Some media (i.e. discs with only one track) may not have transition areas. The means to determine the location of the transition areas is vendor or application-specific and is addressed by other standards (e.g. ISO 9660).

CD is a unique SCSI device in the respect that some logical blocks on a disc may not be accessible by all commands. SEEK commands may be issued to any logical block address within the reported capacity of the disc. READ commands cannot be issued to logical blocks that occur in some transition areas. Audio commands cannot be issued to logical blocks within a data track.

CD media have lead-in and lead-out areas. These areas are outside of the user-accessible area as reported in the READ CD RECORDED CAPACITY data. The lead-in area of the media is designated track zero. The lead-out area is designated track AAh. The Q sub-channel in the lead-in track contains a Table of Contents (TOC) of the disc.

NOTE: The READ CD RECORDED CAPACITY command returns the logical block address of the last block prior to the lead-out area. This location may be in a transition area and therefore not a valid address for read operations.

The Table of Contents gives the absolute MSF location of the first information sector of each track. Control information (audio/data, method of audio encoding, etc.) for each track is also contained in the TOC. However, the TOC does not distinguish between the different modes of data tracks (i.e. CD data mode 1 vs. CD data mode 2).

The MSF locations pointing to the start of data tracks in the TOC are required to be accurate. However, the TOC values for audio tracks have a tolerance of plus or minus 75 sectors. Information from the TOC can be used to reply to a READ CD RECORDED CAPACITY command. When this is done, the device implementor should consider the possible tolerances and return a value that allows access to all information sectors.

An index is a partition of a track. Pre-gap areas are encoded with an index value of zero. Pause areas at the beginning of audio tracks are also encoded with an index value of zero. The first information sector of a track has an index value of one. Consecutive values up to 99 are permitted. Index information is not contained in the TOC. Not all sectors are encoded with the index value in the Q sub-channel data (the requirement is 9 out of 10). A sector without an index value is presumed to have the same index as the preceding sector.

Tracks and indexes are not defined to be any particular length, (except for a minimum track length of 300 sectors.) A CD disc may be created with a single information track that has a single index; or with 99 information tracks, each with 99 indexes.

The sub-channel information which is part of each sector includes a track relative MSF location value giving the distance from the first information sector of the track. On the media, this value decreases during the pre-gap area (sectors with index values of 0) and increases for the rest of the track. The data, returned by the READ SUB-CHANNEL command with MSF bit set to zero, converts this to a track relative logical block address (TRLBA). The TRLBA is continually increasing over the whole track, and pre-gap areas shall return negative values. When the MSF bit in the read sub-channel command is set to one, the MSF track relative location value from the media is reported without change.

#### 4.1.2. Supported Block Sizes

Supported block sizes (see Table 2) include 2048, 2056, 2324, 2332, 2352, 2368, and 2448 bytes. Table 2 - Block Sizes for Read shows the implementation of the various block sizes. These definitions apply for reading with the Read commands.

Table 2 - Block Sizes for Read

Size	Readable block types
2048	Mode 1 or Mode 2 Form 1.
2332	Mode 2, form 1 or 2 data. The drive shall operate as specified for 2048 byte blocks except: Both forms send 2332 byte blocks. Form 1 blocks return the third layer ECC with the user data.
2336	Mode 2 data The drive shall operate as specified for 2048 byte blocks lengths. This mode will include all data, including Yellow Book Mode 2 sectors and Form 1 and Form 2.
2352	Audio or raw blocks. The drive shall operate as specified for 2048 byte blocks. Reads of data mode sectors shall return descrambled data.
2448 or 2368	Audio or raw blocks with raw sub-channel. The drive shall not perform the data descrambling operation.

#### 4.1.3. CD physical data format

The physical format of CD and CD-DA media uses a smaller unit of synchronization than the more familiar magnetic or optical recording systems. The basic data stream synchronization unit is a small frame. This is not the same large frame (sector) as referred to in the MSF unit. Each small frame consists of 588 bits (see Figure 2). A sector on CD media consists of 98 small frames.

1 synchronization pattern (24 + 3 bits)	1 byte of sub-channel data (14 + 3 bits)	12 bytes of data (12 x (14 + 3) bits)	4 bytes of CIRC code (4 x (14 + 3) bits)	12 bytes of data (12 x (14 + 3) bits)	4 bytes of CIRC code (4 x (14 + 3) bits)
588 bits					

Figure 2 - Small Frame layout and definition

Data, sub-channel and CIRC bytes are encoded with an eight-to-fourteen bit code; then three merging bits are added. The merging bits are chosen to provide minimum low-frequency signal content and optimize phase lock loop performance.

##### 4.1.3.1. Frame format for audio

Each frame takes approximately 1/75th of a second to play. This gives a sampling rate of 44.1 kHz for each channel.

##### 4.1.3.2. Q sub-channel information formats

Q sub-channel has a higher level of structure. All the Q sub-channel bits of a sector define the Q sub-channel information block. (For audio tracks, decoding the Q sub-channel is the only way to distinguish sector boundaries.)

The Control, ADR, DATA-Q, and CRC fields contain 96 bits of information defined below.



Field name	Definitions
S0, S1	Sub-Channel Synchronization
CONTROL	The Control Field has 4 bits that define the type of information within a track: 00x0b = 2 audio channels without pre-emphasis 00x1b = 2 audio channels with pre-emphasis of 50/15 $\mu$ s 10x0b = audio channels without pre-emphasis (reserved in CD-R/RW) 10x1b = audio channels with pre-emphasis of 50/15 $\mu$ s (reserved in CD-R/RW) 01x0b = Data track, recorded uninterrupted 01x1b = Data track, recorded incremental 11xxb = reserved xx0xb = digital copy prohibited xx1xb = digital copy permitted The bits of the control field (except for the copy bit) can change during an actual pause (X=00) of at least 2 seconds and during the lead-in area only.
ADR	4 bits of control for DATA-Q.
DATA Q	72 bits of data
CRC	A 16 bit CRC for the Control, ADR, and DATA-Q Fields. On the disc the parity bits are inverted. The remainder has to be checked at zero. Polynomial = $P(X)=X^{16}+X^{12}+X^5+1$

Figure 3 - Q sub-channel Information Block

Three codes are defined for DATA-Q: MODE-1, MODE-2, and MODE-3.

#### 4.1.3.2.1. Q sub-channel Mode-1

ADR = 1 (0001b)

Mode-1 occupies at least 9 out of 10 successive sub-coding blocks. Two different data formats are possible in Mode-1. The data format during the lead-in track is shown in Figure 4 below.

ADR	DATA-Q								
0001	TNO	POINT	MIN	SEC	FRAME	ZERO	PMIN	PSEC	PFRAME

Figure 4 - Q sub-channel Mode-1 Format recorded in lead-in

The format during the data and audio and lead-out tracks on a disc is shown in Figure 5.

ADR	DATA-Q								
0001	TNO	INDEX	MIN	SEC	FRAME	ZERO	AMIN	ASEC	AFRAME

Figure 5 - Q sub-channel Mode-1 Format recorded in Program Area and lead-out

TNO (Track number) on the media is expressed in 2 BCD digits.

- 00bcd      Lead-in. The end of the lead-in is at the starting diameter of the program area.
- 01 - 99bcd      Track numbers. A track can be preceded by a pause with the same track number. The track numbering once set, shall increment by one.
- AAh      Lead-out . The lead-out starts at the end of the last track on a disc, without a preceding pause encoding.

The INDEX (Index to TNO) on the media is 2 BCD digits.

- 00bcd      Pause encoding.
- 01 - 99bcd      Sub-division numbers. During the lead-out track INDEX is 01. Within an audio track (TNO = 01 - 99 and X not equal to 00) the first value of INDEX is 01. The value of INDEX can only be incremented by one. In a data track it shall have a value of 01.

The ZERO field contains a value of ZERO. (00000000 b)

Min, Sec, Frame fields contain the running time within a track expressed in 6 BCD digits. Min, Sec, and Frame are each two digits. The time is set to zero at the start of a track. Time increases in the track and decreases in the pause/pregap, ending with the value zero at the end of the pause/pregap. In the lead-in and the lead-out tracks the time increases.

The minutes are stored in Min, the seconds in Sec. One second is subdivided into 75 Frames (running from 00 to 74).

AMIN, ASEC, AFRAME fields contain the absolute address expressed in 6 BCD digits. AMIN, ASEC, and AFRAME are each two digits. At the starting diameter of the program area the running time is set to zero and TNO takes the value of the first track on the disc.

The minutes are stored in AMIN, the seconds in ASEC. One second is subdivided into 75 AFRAMEs (running from 00 to 74).

Bytes in the Q-sub-channel that contains bcd contents may also contain illegal BCD values. Then values start with 0A0h and continue to 0FFh. No conversion of these to hex for transmission to/from the initiator is performed. Refer to Table 73 for more information.

The POINT, PMIN, PSEC, and PFRAME contain the Table of Contents during the lead-in. This Table of Contents is continuously repeated in the lead-in (TNO = 0). In each Table of Contents, the individual items are repeated three times. At the end of the lead-in, the Table of Contents can be ended with any value of point.

The value of PMIN, PSEC, and PFRAME gives the starting point of the track number pointed to by POINT. These values give the start position of the track on the absolute time scale (AMIN, ASEC, and AFRAME) with an accuracy of +/- one second. The start position of a track is the first position with the new track number and X not equal to 00.

If POINT = A0h, the value of PMIN gives the track number of the first piece of audio on the disc, PSEC and PFRAME are zero.

If POINT = A1h, the value of PMIN gives the track number of the last track on the disc, PSEC and PFRAME are zero.

If POINT = A2h, PMIN, PSEC, and PFRAME contains the starting point of the lead-out.

#### 4.1.3.2.2. Q sub-channel Mode-2

ADR = 2(0010b)

If Mode-2 is present, and occupies at least 1 out of 100 successive sub-coding blocks. Mode-2 data format is:

ADR	DATA-Q														
0010	N1	N2	N3	N4	N5	N6	N7	N8	N9	N10	N11	N12	N13	ZERO	AFRAME

Figure 6 - Q sub-channel Mode-2 Format

The DATA-Q field is 52 bits long and is defined as:

N1 - N13 is the Catalog number of the disc expressed in 13 BCD digits. Used in the UPC/EAN coding. The catalog number does not change on a disc. In case no catalog number is encoded according to the UPC/EAN code, N1 - N13 are all zero, or Mode-2 can be deleted from the disc.

The ZERO field contains 12 bits of zero. (000000000000b)

AFRAME is defined in Q sub-channel Mode-1 (two BCD digits running from 00 to 74). During the lead-in (TNO = 00), these 8 bits are zero.

## 4.1.3.2.3. Q sub-channel Mode-3

ADR = 3 = (0011b)

If Mode-3 is present, it occupies at least 1 out of 100 successive sub-coding blocks. Mode-3 is used to give a unique number to a audio track, This is done by means of the International Standard Recording Code (ISRC). The ISRC, as recorded on the media, is defined in Figure 7. If no ISRC is used, Mode-3 must be deleted. During the lead-in and lead-out, Mode-3 is not present on the disc. The ISRC can only change immediately after the track number (TNO) has been changed. The Mode-3 data format is shown in Figure 7.

ADR	DATA-Q															
0011	I1	I2	I3	I4	I5	0	0	I6	I7	I8	I9	I10	I11	I12	ZERO	AFRAME

Figure 7 - Q sub-channel, Mode-3 Format

I1 - I12 define the ISRC, and is 60 bits in length.

The Country-Code is given in fields I1 through I2, the owner-code in fields I3 - I5, The year of recording in fields I6 - I7 and the I8 through I12 contain the serial number of the recording. The characters I1 - I5 are formatted as shown in Table 3. The characters I6 - I12 are coded in 4 bit BCD numbers.

The ZERO field contains 4 bits of zero. (0000b)

AFRAME is defined in Q sub-channel Mode-1 (two BCD digits running from 00 to 74). During the lead-in area (TNO = 00), these 8 bits are zero.

The 6 bit character coding map is shown in Table 3.

Table 3 - ISRC 6 bit character codes (in hexadecimal)

CHAR	CODE	CHAR	CODE	CHAR	CODE
0	00	G	17	W	27
1	01	H	18	X	28
2	02	I	19	Y	29
3	03	J	1A	Z	2A
4	04	K	1B		
5	05	L	1C		
6	06	M	1D		
7	07	N	1E		
8	08	O	1F		
9	09	P	20		
A	11	Q	21		
B	12	R	22		
C	13	S	23		
D	14	T	24		
E	15	U	25		
F	16	V	26		

## 4.1.3.2.4. Q sub-channel Mode-5

ADR = 5 = (0101b)

4.1.4. CD-ROM Sector Formats

The physical format defined by the CD-ROM media standard provides 2352 bytes per sector. For usual computer data applications, 2048 bytes are used for user data, 12 bytes for a synchronization field, 4 bytes for a sector address tag field and 288 bytes - the auxiliary field - for L-EC (CD-ROM data mode 1). In less critical applications, the auxiliary field may also be used for user data (CD-ROM data Mode 2/Form 2).

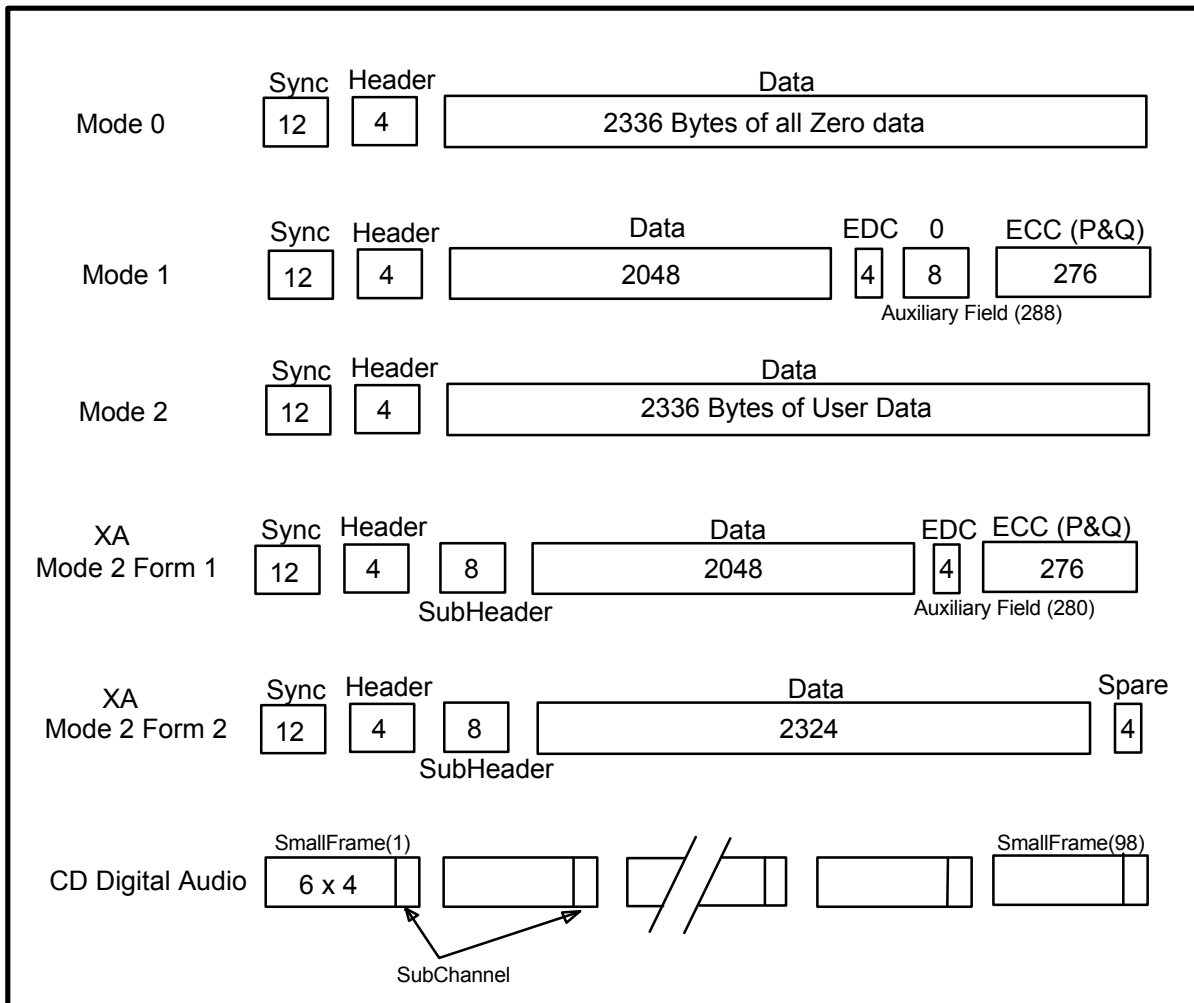

Figure 8 - CD-ROM Sector Formats

A CD-ROM physical sector size is 2048, 2052, 2056, 2324, 2336, 2340, or 2352 bytes per sector. These values correspond to the user data plus various configurations of header, sub-header and EDC/ECC.

4.1.5. CD Audio error reporting

PLAY commands with the immediate bit set in the audio control mode return status as soon as the command has been validated (which may involve a seek to the starting address). The playback operation continues and may complete without notification to the initiator. Error termination of audio operations shall be reported to the initiator by returning immediate CHECK CONDITION status to the next command (except for REQUEST SENSE and INQUIRY). The deferred error sense data (reference SCSI Block Commands standard) is used to indicate that the error is not due to the current command.

The status of the play operation may be determined by issuing a REQUEST SENSE command. The sense key is set to NO SENSE and the audio status (see Table 58) is reported in the additional sense code qualifier field.

## 4.1.6. CD ready condition/not ready condition

The ready condition occurs after a disc is inserted and the drive has performed its initialization tasks. These tasks may include reading the Table of Contents from the media.

A not ready condition shall occur only for the following reasons:

- a) There is no medium mounted.
- b) The drive is unable to load or unload the medium.
- c) The drive is unable to recover the Table of Contents.
- d) The controller cannot select the drive.

**Table 4 - Not Ready Error Reporting (by command)**

Command Name	Operation Code	May Return Not Ready Error
Inquiry	12h	No
Load/Unload CD	A6h	Yes
Mechanism Status	BDh	Yes
Mode Select (10)	55h	No
Mode Sense (10)	5Ah	No
Pause/Resume	4Bh	Yes
Play Audio (10)	45h	Yes
Play Audio (12)	A5h	Yes
Play Audio MSF	47h	Yes
Play CD	BCh	Yes
Read (10)	28h	Yes
Read CD	BEh	Yes
Read CD MSF	B9h	Yes
Read CD Recorded Capacity	25h	Yes
Read Header	44h	Yes
Read Sub-channel	42h	Yes
Read TOC/PMA/ATIP	43h	Yes
Request Sense	03h	No
Scan	BAh	Yes
Seek	2Bh	Yes
Set CD Speed	BBh	No
Stop Play/Scan	4Eh	Yes
Test Unit Ready	00h	Yes

## 4.1.7. CD address reporting formats (MSF bit)

Several CD commands can report addresses either in logical block address or in MSF format (see Table 5). The READ HEADER, READ SUB-CHANNEL, and READ TOC/PMA/ATIP commands have this feature.

Table 5 - MSF Address format

Bit Byte	7	6	5	4	3	2	1	0
0	Reserved							
1	M field							
2	S field							
3	F field							

An MSF bit of zero requests that the logical block address format be used for the CD absolute address field or for the offset from the beginning of the current track expressed as a number of logical blocks in a CD-ROM track relative address field. This track relative logical block address (TRLBA) value is reported as a negative value in twos-complement notation for transition areas that have decreasing MSF encoded relative addresses.

An MSF bit of one requests that the MSF format be used for these fields. In certain transition areas, the relative MSF addresses are decreasing positive values. The absolute MSF addresses are always increasing positive values.

The M, S, and F fields are expressed as binary numbers. The values match those on the media, except for the encoding.

Note: For a logical block size of 512 bytes, the MSF address returned is that for the physical block containing the specified logical blocks.

## 4.1.8. Sensing support for CD-audio commands.

If any commands related to audio operations are implemented, then the PLAY AUDIO command shall be implemented to allow a method for the initiator to determine if audio operations are supported. A target responding to a PLAY AUDIO command which has a transfer length of zero, with CHECK CONDITION status, and setting the sense key to ILLEGAL REQUEST does not support audio play operations.

## 4.1.9. Error reporting

If any of the following conditions occur during the execution of a command, the target shall return CHECK CONDITION status. The appropriate sense key and additional sense code should be set. The following list illustrates some error conditions and the applicable sense keys. The list does not provide an exhaustive enumeration of all conditions that may cause the CHECK CONDITION status.

Table 6 - Sense key responses for error reporting

Condition	Sense Key
Invalid Logical Block Address	ILLEGAL REQUEST
Unsupported option requested	ILLEGAL REQUEST
Attempt to read a blank block	ILLEGAL REQUEST
Attempt to play a data block as audio	ILLEGAL REQUEST
Target reset or medium change since last command	UNIT ATTENTION
Self diagnostic failed	HARDWARE ERROR
Unrecovered read error	MEDIUM ERROR/HARDWARE ERROR
Recovered read error	RECOVERED ERROR
Overrun or other error that might be resolved by repeating the command	ABORTED COMMAND

In the case of an invalid logical block address, the sense data information field shall be set to the logical block address of the first invalid address.

In the case of an attempt to read a blank or previously unwritten block, the sense data information field shall be set to the logical block address of the first blank block encountered. The data read up to that block shall be transferred.

There are other special error situations for CD devices. In the following cases the sense key shall be set to ILLEGAL REQUEST and the additional sense code set to END OF USER AREA ENCOUNTERED ON THIS TRACK:

- a) a pre-gap area is encountered (i.e. a block with index equal to 0).
- b) a post-gap area is encountered.
- c) The information type (data vs. audio) changes.

When the command is other than an audio playback operation, the command shall be terminated with CHECK CONDITION status if the Logical Block Address requested is not within a data track. The sense key shall be set to ILLEGAL REQUEST and the additional sense code set to ILLEGAL MODE FOR THIS TRACK. This applies to audio-combined and audio media.

## 4.2. Changer Model

A changer device will perform exactly like a single CD device. It supports two (2) additional commands, MECHANISM STATUS (BDh) and LOAD/UNLOAD CD (A6h).

A changer device provides a storage area for more than one CD Disc. This storage area contains multiple areas called slots. Each slot can contain just one disc. Once a disc has been placed into a given slot, it becomes locked in that position. This standard provides no capability to move a disc from one slot to another. Thus when a Disc has been moved from a given slot into the playing position, it can only be moved back into the slot that it came from. This shall be followed even if power is lost while a Disc is in the playing position or while it was being moved.

There are two basic types of changer mechanisms, one that has individually addressable eject and load capability and another that uses a cartridge to hold the discs. In the former, individual discs can be changed, while in the latter all the stored discs must be changed at one time.

Any time a disc or cartridge is removed or installed from the changer, the device shall generate an Unit Attention Condition. After the initiator detects the unit attention on a known changer device, the initiator may issue a MECHANISM STATUS Command. This will provide the initiator with information on what disc is present or was changed.

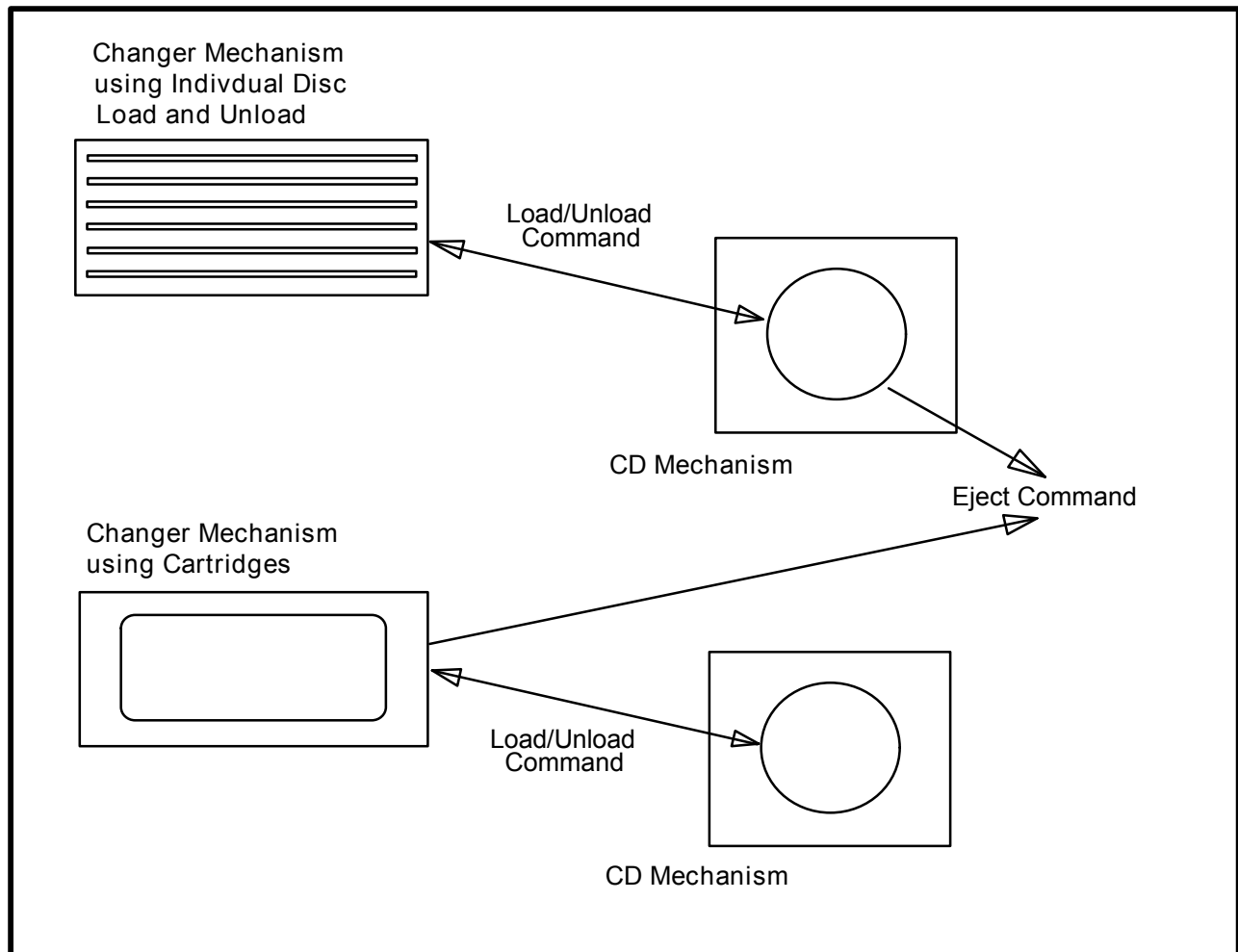

Figure 9 - Media Changer Mechanism Model



4.2.1. Initialization

The Changer shall perform its initialization routine at power on or receipt of a hardware reset from the initiator.

“Initializing Changer” is a process that refers to gathering the information that is necessary to respond to the MECHANISM STATUS Command. If a changer is in the process of initializing when it receives a MECHANISM STATUS Command, it will respond immediately and provide no slot table information (Only the Header).

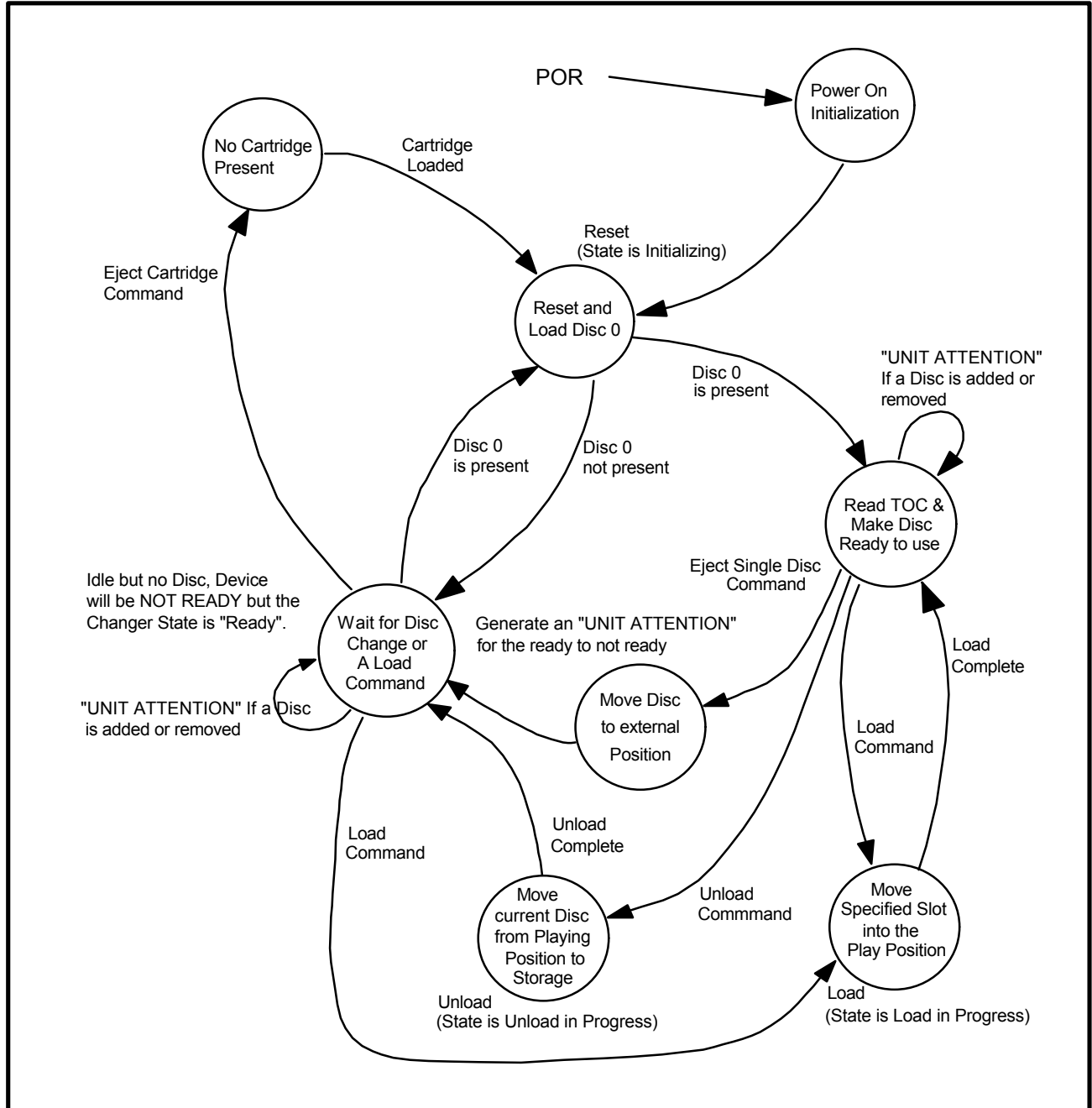

Figure 10 - Changer State Diagram

#### 4.2.2. Changer Addressing

Several Changer specific commands use addresses called "Slots."

If any commands related to Changer operations are implemented, then all the Changer commands shall be implemented. To determine if a drive is a changer type device, the Loading Mechanism Type field in the Capabilities page will contain one of the two changer type code (See Table 103 - CD Capabilities and Mechanical Status Page) for individual disc or cartridge implementations.

#### 4.2.3. Automatic Load and Unload Operations

After initialization is complete the changer shall have Disc 0 loaded into the play position. This enables drivers which are not changer aware to work with a changer device as if it were a normal single CD device. This also ensures compatibility with a Bootable CD. In support of this goal the changer shall also load and unload (Eject) default Disc 0 if the changer supports loading and unloading (Ejecting) individual Discs unless otherwise commanded by the use of one of the changer specific Load/Unload commands.

When a LOAD Command is received and a Disc is present in the Playing position, it shall be unloaded automatically before the specified Load operation is performed.

#### 4.2.4. Delayed Disc load operation

CD Changer Devices may either move a disc into the playing position immediately upon receipt of a LOAD command, or delay the loading of the disc until a media access command is received. It is recommended that the device not load discs into the playing position until data from a disc that is not cached is requested from the initiator.

Note that Initiator drivers should expect to encounter load mechanism delays on media accesses in addition to the spin up and seek delays normally introduced with these commands.

If the device supports delayed loading and the selected disc is not in the play position, then the following commands shall move the selected disc into the play position when data that has not been cached has been requested by the initiator:

**Table 7 - Commands that may cause delayed loads to occur**

Command
Play Audio (10)
Play Audio MSF
Play CD
Read (10)
Read (12)
Read CD
Read CD MSF
Read CD-ROM Capacity
Read Header
Read Sub-Channel
Read TOC
Scan

If the device supports delayed loading and the selected disc is not in the play position, then the following commands shall load the selected disc into the play position before execution of the command. ( See Table 8 below)

**Table 8 - Commands that will cause delayed loads to occur**

Command
Seek
Start/Stop Unit (LoEj=1)

If the device supports delayed loading and the selected disc is not in the play position, then the following commands shall not move the selected disc into the play position. (See Table 9 below)

**Table 9 - Commands that should not cause delayed loads to occur**

Command
Stop Play/Scan
Start/Stop Unit (LoEj=0)
Test Unit Ready
Inquiry
Mechanism Status
Mode Select
Mode Sense
Prevent/Allow Medium Removal
Request Sense
Set CD Speed

#### 4.2.5. Prevent / Allow processing

There are two techniques for Prevent / Allow: either all the discs shall be prevented from being ejected by the user or each disc individually shall be prevented. If the device reports support for Software Slot Selection, then each slot shall be individually controlled by the Prevent / Allow command. Note that changer devices that use a Cartridge and not individually controlled slots should not report the Software Slot Selection capability.

#### 4.2.6. Error Reporting

If any of the following conditions occur during the execution of a command, the Changer shall return CHECK CONDITION status. The appropriate sense key and additional sense code shall be set. Table 10 below list some error conditions and the applicable sense keys. The list does not provide an exhaustive enumeration of all conditions that may cause the CHECK CONDITION status.

**Table 10 - Error Conditions and Sense Keys for Changer Mechanisms**

Condition	Sense Key
Invalid Slot Number	ILLEGAL REQUEST
Unsupported option requested	ILLEGAL REQUEST
Load or Unload to invalid slot or no Disc in source location	ILLEGAL REQUEST
CD-ROM Drive reset or medium change since last command	UNIT ATTENTION
Self diagnostic failed	HARDWARE ERROR

In the case of an invalid Slot number, the sense data information field shall be set to the Slot number of the first invalid address.

Attempts to eject a Disc if the changer type is cartridge and there is a Disc in the playing position shall be rejected with a Sense Key 05, (ILLEGAL REQUEST) Sense Code 01 (MECHANICAL POSITIONING OR CHANGER ERROR).

## 5. CD Commands

Commands which may be implemented common to some or all SCSI device types are listed in other SCSI-3 standards. For a complete description of these commands reference SCSI-3 Primary Commands, and SCSI-3 Block Commands.

### 5.1. CD Command Listing

Commands referenced for CD devices are listed in Table 11. These commands are described in the following sub-clauses.

Table 11 - Multimedia Commands Specific to CD Devices

Command Name	Operation Code	Type	Sub-clause
INQUIRY	12h	M	SPC
Load/Unload CD	A6h	O	5.1.1.
Mechanism Status	BDh	M	5.1.2.
MODE SELECT (6)	15h	M	SPC
MODE SENSE (10)	5Ah	M	SPC
MODE SENSE (6)	1Ah	M	SPC
Pause/Resume	4Bh	A	5.1.3.
Play Audio (10)	45h	A	5.1.4.
Play Audio (12)	A5h	A	5.1.5.
Play Audio MSF	47h	A	5.1.6.
Play CD	BCh	O	5.1.7.
PREVENT/ALLOW MEDIUM REMOVAL	1Eh	M	SPC
READ (10)	28h	M	SPC
Read CD	BEh	O	5.1.8.
Read CD MSF	B9h	O	5.1.9.
Read CD Recorded Capacity	25h	M	5.1.10.
Read Header	44h	M	5.1.11.
Read Sub-channel	42h	M	5.1.12.
Read TOC/PMA/ATIP	43h	M	5.1.13.
RELEASE (10)	57h	M	SPC
REQUEST SENSE	03h	M	SPC
RESERVE(10)	56h	M	SPC
Scan	BAh	O	5.1.14.
SEEK (10)	2Bh	M	SPC
SEEK (6)	0Bh	M	SPC
SEND DIAGNOSTIC	1Dh	M	SPC
Set CD Speed	BBh	R	5.1.15.
START/STOP UNIT	1Bh	M	SPC
Stop Play/Scan	4Eh	A	5.1.16.
TEST UNIT READY	00h	M	SPC

Key: M = command implementation is mandatory  
 O = command implementation is optional  
 A = mandatory command when implementing Audio  
 R = mandatory command for CD-R/RW devices

## 5.1.1. LOAD/UNLOAD CD Command

The LOAD/UNLOAD Command (Table 12) requests the device changer load or unload a Disc. New LOAD/UNLOAD commands issued before the changer enters the READY STATE (00b), see Table 18, should cause the changer to stop any LOAD/UNLOAD Command in progress and begin processing the new Load/Unload CD command.

Table 12 - LOAD/UNLOAD CD command

Bit Byte	7	6	5	4	3	2	1	0
0	OPERATION CODE (A6h)							
1	Reserved			Reserved			Immed	
2	Reserved							
3	Reserved							
4	Reserved					LoUnlo		Start
5	Reserved							
6	Reserved							
7	Reserved							
8	SLOT							
9	Reserved							
10	Reserved							
11	Control							

An immediate (Immed) bit of one indicates that the target shall return status as soon as the command descriptor block has been validated. An Immed Bit of zero indicates that the status shall not be returned until the operation has been completed.

The Load/Unload (LoUnlo) bit and the Start bit encoding is shown in Table 13

Table 13 - Load/Unload Operations

LoUnlo	Start	Operation to be Performed
0	0	Abort any prior Changer command (Stop)
0	1	Reserved
1	0	Unload media. The Slot Parameter is ignored for this operation.
1	1	Load the Media from specified Slot and initialize

The SLOT field indicated the Slot to be loaded or unloaded. Changer should always initialize (Load) Slot 0 on Power On or Bus Device Reset.

Any attempt to Load or Unload a Disc when the Device does not support that capability shall result in a Check Condition being reported to the Initiator with Sense key ILLEGAL REQUEST, Sense Code INVALID FIELD IN COMMAND DESCRIPTOR BLOCK.

Loading when the slot does not contain a Disc or the Play Position does not contain a Disc will be rejected with Sense Key ILLEGAL REQUEST, Sense Code INVALID FIELD IN COMMAND DESCRIPTOR BLOCK for the Slot Bytes. Unloading when the Play Position does not contain a Disc will be rejected with a Sense Key ILLEGAL REQUEST, Sense Code INVALID FIELD IN COMMAND DESCRIPTOR BLOCK for the Slot Bytes.

Loading when the slot does not contain a Disc will be rejected with a Sense Key NOT READY and Sense Code 3Ah MEDIUM NOT PRESENT. When this error is returned there are two possible actions by the CD Changer Device. If the device reports Software Slot Selection (SSS) = 1, (see Table 103), then the slot specified shall be selected for use. If the device reports SSS = 0 then the previously used slot shall continue to be selected for use.

If the drive is capable of caching data then a delayed load of a disc into the playing position can be supported. If delayed loading of a disc into the playing position is supported, the device shall have previously cached the TOC data from that disc. If the device has not read the TOC for a disc that is being loaded into the playing position, then delayed loading shall not be performed and the disc shall be loaded into the playing position immediately. If Caching of TOC data has been performed and the loading of the Disc into the playing position is delayed, then the drive shall report that the Disc is ready, even though the Disc is not spinning and installed in the playing position. In all cases the behavior seen by the initiator (other than a longer subsequent media access latency) shall not be different between delayed and immediate loading of a disc.

A UNIT ATTENTION Condition shall not be generated when discs are loaded or unloaded from the playing position.

**Table 14 - Recommended errors for Load/Unload CD operation**

Error	Reference
Deferred Errors	Sub-clause A.1
General Errors	Table A.2
MECHANICAL POSITIONING ERROR	Table A.1
INVALID ELEMENT ADDRESS	Table A.1
MEDIA LOAD OR EJECT FAILED	Table A.1

## 5.1.2. MECHANISM STATUS Command

The Mechanism Status command (Table 15) requests that the CD device respond with the current status of the CD Device, including any Changer Mechanism that adheres to this standard. This command is intended to provide information to the Initiator about the current operational state of the device. The CD Devices take operational direction from both the Initiator and the user. Movement of media in/out of the device as well as Play operation may be due to external controls or initiator commands. This command provides a method that allows the Initiator to know what has transpired with the changer mechanism.

Table 15 - MECHANISM STATUS Command Descriptor Block

Bit Byte	7	6	5	4	3	2	1	0
0	Operation code (BDh)							
1	Reserved							
2	Reserved							
3	Reserved							
4	Reserved							
5	Reserved							
6	Reserved							
7	Reserved							
8	(MSB) Allocation Length (LSB)							
9								
10	Reserved							
11	Control							

The Allocation Length field specifies the maximum length in bytes of the Mechanical Status Parameter list, see Table 16 that shall be transferred from the device to the Initiator. An Allocation Length field of zero indicates that no data shall be transferred. This condition shall not be considered an error.



The Mechanism Status Parameter list (Table 16) returned contains a header (Table 17), followed by zero or more fixed-length Slot Tables. If the device does not support the changer commands, then the number of slot tables returned to the initiator shall be zero.

**Table 16 - Mechanism Status Parameter List**

Bit	7	6	5	4	3	2	1	0
Byte								
0-7	Mechanism Status Header							
8-n	Slot Table(s)							

**Table 17 - Mechanism Status Header**

Bit	7	6	5	4	3	2	1	0
Byte								
0	Fault	Changer State	Current Slot					
1	CD Mechanism State			Door open	Reserved			
2	(MSB) Current LBA (LSB)							
3								
4								
5								
6	(MSB) Length of Slot Table(s)							
7	(LSB)							
8 - n	Slot Tables (0-n)							

The Fault bit, bit 7, indicates that the changer failed to complete the operation reported in the Changer State field.

The Changer State field (Table 18), indicates the current state of the changer.

**Table 18 - Changer State Field**

Changer State	Definition
0h	Ready
1h	Load in Progress
2h	Unload in Progress
3h	Initializing

The Current Slot field indicates the Current Slot selected. Changers compatible with a bootable CD specification should always initialize (Load) Slot zero on Power On or Bus Device Reset.

The CD Mechanism State field (Table 19) encodes the current operation of CD Mechanism.

**Table 19 - CD Mechanism State Field**

CD Mechanism State	Definition
0h	Idle
1h	Playing (Audio or Data)
2h	Scanning
3h-6h	Reserved
7h	Initializing

The slot table response data format is defined in Table 20. Each slot shall respond with the status defined.

The Door open bit when set, indicates that the Door(s) or Tray(s) is open or the cartridge is not present.

**Table 20 - Slot Table Response Format**

Bit Byte	7	6	5	4	3	2	1	0
0	Disc Present (Optional)	Reserved	Reserved	Reserved	Reserved	Reserved	Reserved	Change (Mandatory)
1	Reserved							
2	Reserved							
3	Reserved							

The Disc Present bit, bit 7, indicates that there is a Disc in this slot. The reporting of this information is optional after a reset or Disc change. If this feature is not supported, this bit shall be set to one after a reset condition or when a medium has been changed. When the device is given a load command for a slot that contains no Disc, the bit corresponding to that slot shall then contain a 0 for any following response. If this bit is valid after a reset or medium change, then this capability shall be reported in the CD Capabilities and Mechanical Status Page (see Table 103).

The Change bit, bit 0, indicates that the Disc in that slot has been changed since the last time the disc was loaded.

The Number of Slots Available field indicates the number of slots available. The maximum number of slots is 32.

**Table 21 - Recommended errors for Mechanism Status command**

Error	Reference
Deferred Errors	Sub-clause A.1
General Errors	Table A.2

## 5.1.3. PAUSE/RESUME Command

The PAUSE/RESUME command (Table 22) requests that the device stop or start a playback operation. This command is used with PLAY AUDIO and Play CD commands that are executing in immediate mode.

Table 22 - PAUSE/RESUME Command Descriptor Block

Bit Byte	7	6	5	4	3	2	1	0
0	OPERATION CODE (4Bh)							
1	Reserved			Reserved				
2	Reserved							
3	Reserved							
4	Reserved							
5	Reserved							
6	Reserved							
7	Reserved							
8	Reserved							Resume
9	Control							

A Resume bit of zero causes the drive to enter the hold track state with the audio output muted after the current block is played. A Resume bit of one causes the drive to release the pause/scan and begin play at the block following the last block played/scanned.

If an audio play operation cannot be resumed and the Resume bit is one, the command is terminated with CHECK CONDITION status, COMMAND SEQUENCE ERROR. If the Resume bit is zero and an audio play operation cannot be paused, (no audio play operation has been requested, or the requested audio play operation has been completed), the command is terminated with CHECK CONDITION status, COMMAND SEQUENCE ERROR.

It shall not be considered an error to request a Pause when a pause is already in effect, or to request a Resume when a play operation is in progress.

Table 23 - Recommended errors for PAUSE/RESUME command

Error	Reference
Deferred Errors	Sub-clause A.1
General Errors	Table A.2
COMMAND SEQUENCE ERROR	Table A.1

## 5.1.4. PLAY AUDIO(10) Command

The PLAY AUDIO command (Table 24) requests that the target begin an audio playback operation.

When the PLAY AUDIO is in progress, the behavior of specific commands in relation to the play operation is specified in Annex C.

Table 24 - PLAY AUDIO(10) Command Descriptor Block

Bit Byte	7	6	5	4	3	2	1	0
0	OPERATION CODE (45h)							
1	Reserved			Reserved			RELADR	
2	(MSB) Starting Logical Block Address (LSB)							
3								
4								
5								
6								
7	(MSB) Transfer Length (LSB)							
8								
9								

The RELADR bit shall be set to zero.

The starting logical block address field specifies the logical block at which the audio playback operation shall begin. PLAY AUDIO commands with a starting logical block address of FFFF FFFFh shall implement audio play from the current location of the optics. PLAY AUDIO commands with a starting LBA address of 0000 0000h shall begin the audio play operation at 00/02/00 MSF.

The transfer length field specifies the number of contiguous logical blocks that shall be played. A transfer length field of zero indicates that no audio operation shall occur. This condition shall not be considered an error.

If the starting address is not found, the command shall be terminated with CHECK CONDITION status, LOGICAL BLOCK ADDRESS OUT OF RANGE.

If the starting address is not within an audio track, the command shall be terminated with CHECK CONDITION status, ILLEGAL MODE FOR THIS TRACK.

If the CD sub-channel mode type is other than audio the command shall be terminated with a CHECK CONDITION and the sense key shall be set to ILLEGAL REQUEST and additional sense code set to END OF USER AREA ENCOUNTERED ON THIS TRACK.

Table 25 - Recommended errors for PLAY AUDIO(10) Command

Error	Reference
Deferred Errors	Sub-clause A.1
General Errors	Table A.2
Media Access Errors	Table A.3

## 5.1.5. PLAY AUDIO(12) Command

The PLAY AUDIO(12) command (Table 26) requests that the target to begin an audio playback operation. The command function and the output audio signals shall be as specified by the CD audio control mode page (see Table 97).

When the PLAY AUDIO is in progress, the behavior of specific commands in relation to the play operation is specified in Annex C.

Table 26 - PLAY AUDIO(12) Command Descriptor Block

Bit Byte	7	6	5	4	3	2	1	0
0	OPERATION CODE (A5h)							
1	Reserved			Reserved			RELADR	
2	(MSB) Logical Block Address (LSB)							
3								
4								
5								
6								
6	(MSB) Transfer Length (LSB)							
7								
8								
9								
10	Reserved							
11	Control							

The starting logical block address field specifies the logical block at which the audio playback operation shall begin. PLAY AUDIO commands with a starting address logical block address of FFFF FFFFh shall implement audio play from the current location of the optics. PLAY AUDIO commands with a starting LBA address of 0000 0000h shall begin the audio play operation at 00/02/00 MSF.

The transfer length field specifies the number of contiguous logical blocks that shall be played. A transfer length field of zero indicates that no audio operation shall occur. This condition shall not be considered an error.

If the starting address is not found, , the command shall be terminated with CHECK CONDITION status, LOGICAL BLOCK ADDRESS OUT OF RANGE.

If the starting address is not within an audio track, the command shall be terminated with CHECK CONDITION status, ILLEGAL MODE FOR THIS TRACK.

Table 27 - Recommended errors for PLAY AUDIO(12) Command

Error	Reference
Deferred Errors	Sub-clause A.1
General Errors	Table A.2
Media Access Errors	Table A.3

## 5.1.6. PLAY AUDIO MSF Command

The PLAY AUDIO MSF command (Table 28) requests that the target to begin an audio playback operation.

Table 28 - PLAY AUDIO MSF Command Descriptor Block

Bit Byte	7	6	5	4	3	2	1	0
0	OPERATION CODE (47h)							
1	Reserved			Reserved				
2	Reserved							
3	Starting M Field							
4	Starting S Field							
5	Starting F Field							
6	Ending M Field							
7	Ending S Field							
8	Ending F Field							
9	Control							

When the PLAY AUDIO is in progress, the behavior of specific commands in relation to the play operation is specified in Annex C Command Play/Scan Operation (normative).

The starting M field, the starting S field, and the starting F field specify the absolute MSF address that the audio play operation shall begin. The ending M field, the ending S field, and the ending F field specify the absolute MSF address where the audio play operation shall end. All contiguous audio sectors between the starting and the ending MSF address shall be played.

If the Starting Minutes, Seconds, and Frame Fields are set to FFh, the Starting address is taken from the Current Optical Head location. This allows the Audio Ending address to be changed without interrupting the current playback operation.

A starting MSF address equal to an ending MSF address causes no audio play operation to occur. This shall not be considered an error. If the starting MSF address is greater than the ending MSF address, the command shall be terminated with CHECK CONDITION status, INVALID FIELD IN CDB.

Table 29 - Recommended errors for PLAY AUDIO MSF Command

Error	Reference
Deferred Errors	Sub-clause A.1
General Errors	Table A.2
Media Access Errors	Table A.3

## 5.1.7. Play CD Command

The Play CD Command (Table 30) defines the way digital CD data shall be sent to an external port.

Table 30 - PLAY CD Command Descriptor Block

Bit Byte	7	6	5	4	3	2	1	0
0	OPERATION CODE (BCh)							
1	Reserved			Expected Sector Type		CMSF	Reserved	
2	(MSB) Starting Logical Block Address							
3								
4								
5								
6	(MSB) Play Length in Blocks							
7								
8								
9								
10	Speed	Reserved			Port 2	Port 1	Composite	Audio
11	Control							

The Expected Sector Type field (Table 31) is used to check the sector type only. If the Requested Sector(s) do not match the specified type, the command will be terminated with a Check Condition, ILLEGAL MODE FOR THIS TRACK. The sector that does not match will not be transferred..

Table 31 - Expected Sector type field bit definitions

Sector Type	Definition	Description
000b	All types (mandatory)	No checking of the data type is performed. The device shall always terminate a command at the sector where a transition between CD-ROM and CD-DA data occurs.
001b	CD-DA (optional)	Only IEC 908:1987 (CD-DA) (see Figure 8) sectors shall be returned. All other data formats encountered return an error.
010b	Mode 1 (mandatory)	Only Yellow Book (see Figure 8) sectors with a user data field of 2048 bytes shall be returned. All other data formats encountered return an error.
011b	Mode 2 formless (mandatory)	Only Yellow Book (see Figure 8) sectors with the expanded user data field (2336 bytes) shall be returned. All other formats encountered will terminate the command and return CHECK condition.
100b	Mode 2 form 1 (mandatory)	Only sectors (see Figure 8) which have a user data field of 2048 bytes will be returned. All other formats encountered will terminate the command and return CHECK condition.
101b	Mode 2 form 2 (mandatory)	Only sectors (see Figure 8) which have a user data field of 2324 shall be returned. All other formats encountered will terminate the command and return CHECK condition. note: 4 spare bytes are included making the total data length returned 2328 bytes/sector.
110b-111b	Reserved	

If the CMSF bit is set to zero, the Starting Logical Block Address field specifies the logical block at which the playback operation shall begin. If the CMSF bit is set to one, bytes 3 through 5 specify the MSF starting address and bytes 6 through 8 indicate the ending MSF address. Bytes 2 and 9 are reserved if CMSF is set to one.

PLAY CD commands with a starting LBA address of 0000 0000h shall begin the play operation at 00/02/00 MSF.

If the Starting Logical Block Address is set to 'FF FF FF FFh' (or '00 FF FF FFh' when CMSF is one) and the playback operation is in progress, or the drive is in the hold track state, the drive shall change the Transfer Length (or Ending Address when CMSF is one) without interrupting current playback operation. If there is no playback operation in progress the drive shall implement the playback operation from the current location of the optics.

The Play Length field specifies the number of contiguous logical blocks that shall be played. A Play Length field of zero indicates that no play operation shall occur. This condition shall not be considered an error.

If the starting address is not found, the command shall be terminated with CHECK CONDITION status, LOGICAL BLOCK ADDRESS OUT OF RANGE.

Byte 10 of the command descriptor block defines a group of bits that define the play operations for this command.

Table 32 defines the Field definitions for PLAY CD.

**Table 32 - PLAY CD, Field definition**

Byte 10 bit	Value	Description
Audio	0	Analog Audio Channel is Disabled
	1	Analog Audio Channel is Enabled
Composite	0	Composite Video port is Disabled
	1	Composite Video port is Enabled
Port 1	0	Digital Port 1 is Disabled
	1	Digital Port 1 is Enabled
Port 2	0	Digital Port 2 is Disabled
	1	Digital Port 2 is Enabled
Speed	0	Speed will be set to X1 for the operation
	1	The speed used will be the best possible

**Table 33 - Recommended errors PLAY CD Command**

Error	Reference
Deferred Errors	Sub-clause A.1
General Errors	Table A.2
Media Access Errors	Table A.3



## 5.1.8. READ CD Command

The READ CD Command described in Table 34 provides a single standard command format for accessing CD data. This command is generic to all types of CD data formats.

This command returns any of the defined CD data streams, including the headers, EDC, ECC, user data and CD-DA data. Each type of data is enabled via the fields in the READ CD command descriptor block (see Table 34). These fields indicate which information from the CD is to be returned in the data stream. If a bit is cleared, then that particular information is not returned. If all the fields contain zero then no information is returned. This condition shall not be considered an error.

Table 34 - READ CD Command Descriptor Block

Bit Byte	7	6	5	4	3	2	1	0
0	OPERATION CODE (BEh)							
1	RESERVED			Sector Type			Reserved	RELADR
2	(MSB) Starting Logical Block Address (LSB)							
3								
4								
5								
6								
6	(MSB) Transfer Length in Blocks (LSB)							
7								
8								
9	SYNC	Header Codes	User Data	EDC & ECC	Error Field	Reserved		
10	Reserved				Sub-Channel Selection Bits			
11	Control							

The RELADR bit shall be set to zero.

The Sector type field is used as a filter or mask to select the types of data format information returned to the initiator. A transfer operation is terminated as soon as data is encountered that does not match one of those specified in the sector type field of the command. If the requested data is not of the type/types requested, the command will be terminated with a Check Condition status, ILLEGAL MODE FOR THIS TRACK. The sector/sectors which do not match will not be transferred to the initiator. .

The Sync bit, set to one, indicates that the Sync field from the sector will be included in the data stream. The Sync bit, set to zero indicates the Sync field will not be included in the data stream.

The Header Code field (Table 35) is encoded to select Header/Sub-header information that should be included in the returned data stream.

**Table 35 - Header Code field definition**

Header Code	Definition	Description
00b	none	no header information shall be returned
01b	Hdr only	Only the four byte header will be returned in the data stream
10b	sub-header only	Only the mode 2 form 1 or form 2 sub-header will be returned.
11b	All headers	Return both header and sub-header information

The User data bit, when set to one, indicates that the user data part of a CD sector shall be returned in the data stream. When set to zero, user data shall not be returned to the initiator. The setting of the Mode Select Block Size does not apply to this command. If the current track is an audio track, then audio data will be returned. Otherwise, the normal user data will be returned.

The EDC and ECC bit, when set to one, indicates that the EDC and ECC (L-EC) field shall be included in the data stream. For Mode 1 CD format, this will include the 8 bytes of pad data.

The Error field(see Table 36) is an encoded field that indicates which if any of the C2 and/or Block error data will be included in the data stream. All of the field types are mandatory. If the drive does not support the C2 pointers (as reported in the mode sense capabilities page) the data returned shall be zero filled.

**Table 36 - READ CD, Error field definition**

Error Field	Definition	Description
00b	none	No error information is returned
01b	C2 error block data	The C2 error, Pointer bits (2352 bits or 294 bytes) will be included in the data stream. There will be one bit for each byte in error in the sector (2352 total). The bit ordering is from the most significant bit to the least significant bit in each byte. The first bytes in the sector will be the first bits/bytes in the data stream.
10b	C2 and Block Error Bits	Both the C2 error bits (2352 bits/294 bytes) and the Block Error Byte will be included in the data stream. The Block Error Byte is the logical or of all the C2 Error bit bytes. The Error Byte will be padded with a byte (undefined) to ensure an even number of bytes in the data stream. The Block error byte will be first in the data stream followed by the pad byte.
11b	Reserved	

The Sub-channel data selection field (see Table 37) indicates which CD Sub-Channel information is to be included in the data stream. This may be the Q information and/or the "Raw" sub-channel information. If the field is set to a nonzero value, then that Sub-channel data will be included in the data stream to the initiator.

Table 37 - READ CD, Sub-channel Data Selection Field definition

Sub-Channel data selection value	Definition	Description	Type
000b	No sub-channel data	No sub-channel data will be returned	Mandatory
001b	RAW	RAW P-W sub-channel data will be transferred	Optional
010b	Q	Q data is transferred (see Table 38)	Optional
011b	Reserved		
100b	P-W	R-W data is transferred	Optional
101b-111b	Reserved		

In the case of R-W the drive may return the data de-interleaved and error corrected, RAW or padded with zeroes depending on the R-W supported and R-W de-interleaved and error corrected bits in the CD capabilities and Mechanism status page. In the case of RAW the drive will return the P-W sub-channel data that is not de-interleaved. See Table 42 and Table 43 for P-W data formats.

If the Starting Logical Block Address is set to FFFF FFFFh and the only information requested to be placed in the data stream is the Sub-channel data and there is currently a PLAY AUDIO command in process, the actual address used will be from the current location (of the audio play).

Table 38 - Formatted Q sub-channel response data

Byte	Description
0	Control (4 ms bits), ADR (4 Ls bits)
1	Track number
2	Index number
3	Min
4	Sec
5	Frame
6	ZERO
7	AMIN
8	ASEC
9	AFRAME
10	CRC** or 00h
11	CRC** or 00h
12	00h (pad)
13	00h (pad)
14	00h (pad)
15	MSB is P-Sub-code(optional), all others are 0h

\*\* CRC is optional

All data returned to the initiator is converted to hex from bcd. Data stored on the media is formatted in bcd values.

The lengths of the data returned from a READ CD command vary based on the type of sector that is being read and the requested fields to be returned to the initiator. Many combinations are possible, but most are not very useful. Table 39 specifies how the device responds to many of the requests. Requests for transfers not specified in the Table 39 shall not be supported and treated as illegal. Illegal values will cause the command to be aborted with a Check Condition status, INVALID FIELD IN CDB. See Figure 8 for definition of sector formats.

Table 39 - Number of Bytes Returned Based on Data Selection Field

Data to be transferred	Byte <sup>2</sup> 9	CD-DA	Mode 1	Mode 2	Mode 2 Form 1	Mode 2 Form 2
User Data	10h	2352	2048 <sup>1</sup>	2336 <sup>1</sup>	2048	2328 <sup>1</sup>
User Data + EDC/ECC	18h	(10h) <sup>1</sup>	2336	(10h) <sup>1</sup>	2328	(10h) <sup>1</sup>
Header	20h	(10h) <sup>1</sup>	4	4	4	4
Header Only + EDC/ECC	28h	(10h) <sup>1</sup>	Illegal	Illegal	Illegal	Illegal
Header & user data	30h	(10h) <sup>1</sup>	2052 <sup>1</sup>	2340 <sup>1</sup>	Illegal	Illegal
Header & User Data + EDC/ECC	38h	(10h) <sup>1</sup>	2340	(30h) <sup>1</sup>	Illegal	Illegal
Sub Header Only	40h	(10h) <sup>1</sup>	0	0	8	8
Sub Header Only + EDC/ECC	48h	(10h) <sup>1</sup>	Illegal	Illegal	Illegal	Illegal
Sub Header & user data	50h	(10h) <sup>1</sup>	(10h) <sup>1</sup>	(10h) <sup>1</sup>	2056 <sup>1</sup>	2336 <sup>1</sup>
Sub Header & user data + EDC/ECC	58h	(10h) <sup>1</sup>	(18h) <sup>1</sup>	(10h) <sup>1</sup>	2336	(50h) <sup>1</sup>
All Headers Only	60h	(10h) <sup>1</sup>	4	4	12	12
All Headers Only + EDC/ECC	68h	(10h) <sup>1</sup>	Illegal	Illegal	Illegal	Illegal
All Headers & user data	70h	(10h) <sup>1</sup>	(30h) <sup>1</sup>	(30h) <sup>1</sup>	2060 <sup>1</sup>	2340 <sup>1</sup>
All Headers & user data + EDC/ECC	78h	(10h) <sup>1</sup>	(38h) <sup>1</sup>	(30h) <sup>1</sup>	2340	2340
Sync & User Data	90h	(10h) <sup>1</sup>	Illegal	Illegal	Illegal	Illegal
Sync & User Data + EDC/ECC	98h	(10h) <sup>1</sup>	Illegal	Illegal	Illegal	Illegal
Sync & Header Only	A0h	(10h) <sup>1</sup>	16	16	16	16
Sync & Header Only + EDC/ECC	A8h	(10h) <sup>1</sup>	Illegal	Illegal	Illegal	Illegal
Sync & Header User Data	B0h	(10h) <sup>1</sup>	2064	2352	Illegal	Illegal
Sync & Header User Data + EDC/ECC	B8h	(10h) <sup>1</sup>	2352	(B0h)	Illegal	Illegal
Sync & Sub Header Only	C0h	(10h) <sup>1</sup>	Illegal	Illegal	Illegal	Illegal
Sync & Sub Header Only + EDC/ECC	C8h	(10h) <sup>1</sup>	Illegal	Illegal	Illegal	Illegal
Sync & Sub Header & User Data	D0h	(10h) <sup>1</sup>	Illegal	Illegal	Illegal	Illegal
Sync & Sub Header & User Data + EDC/ECC	D8h	(10h) <sup>1</sup>	Illegal	Illegal	Illegal	Illegal
Sync & All Headers Only	E0h	(10h) <sup>1</sup>	16	16	24	24
Sync & All Headers Only + EDC/ECC	E8h	(10h) <sup>1</sup>	Illegal	Illegal	Illegal	Illegal
Sync & All Headers & user data	F0h	(10h) <sup>1</sup>	2064	2352 <sup>1</sup>	2072	2352 <sup>1</sup>
Sync & All Headers & user data + EDC/ECC	F8h	(10h) <sup>1</sup>	2352 <sup>1</sup>	(F0h) <sup>1</sup>	2352 <sup>1</sup>	(F0h) <sup>1</sup>
Repeat 10h - F8h and Add Error Bits	02h	+294 <sup>3</sup>	+294	+294	+294	+294
Repeat 10h - F8h and Add Block & Error Bits	04h	+296	+296	+296	+296	+296

Note:

1. These values are most useful to the initiator and shall return the number of bytes specified, if supported.
2. Byte 9 of the READ CD Command Descriptor Block
3. + indicates the addition of the specified number of bytes to the stream of the data.

For definitions of the headers of Table 39 refer to sub-clause 4.1.4. CD-ROM Sector Formats

Values enclosed in ( ) indicate that the amount of data is the same as the Flag byte setting specified by the contents of the parenthesis.

Table 40 - Recommended errors for READ CD command

Error	Reference
Deferred Errors	Sub-clause A.1
General Errors	Table A.2
Media Access Errors	Table A.3
READ ERROR - LOSS OF STREAMING	Table A.1

The CD-DA audio data includes 16 bits of information for each channel, and will be formatted as follows when an audio track is read. See Table 41.

Table 41 - CD-DA (Digital Audio) Data Block Format

Bit Byte	7	6	5	4	3	2	1	0
0	Left Channel (Lower Byte) (LSB)							
1	(MSB)	Left Channel (Upper Byte)						
2	Right Channel (Lower Byte) (LSB)							
3	(MSB)	Right Channel (Upper Byte)						
2348	Left Channel (Lower Byte) (LSB)							
2349	(MSB)	Left Channel (Upper Byte)						
2350	Right Channel (Lower Byte) (LSB)							
2351	(MSB)	Right Channel (Upper Byte)						

If the CD Drive does not support the CD-DA Stream-Is-Accurate capability, See Table 103 - CD Capabilities and Mechanical Status Page, then the digital audio data must be read as a continuous stream. If while streaming the drive must stop, there will be a non recoverable error generated READ ERROR - LOSS OF STREAMING. This is due to the 1 second uncertainty of the address. (i.e. there is no header in CD-DA data). Reissuing the command may not return exactly the same data as the previous try. When the drive supports the stream accurate capability, there will be no error, only some time delay for rotational latency.

The format for R-W raw data is described in Table 42.

Table 42 - P-W RAW data format

Bit Byte	7	6	5	4	3	2	1	0
0	P-W (0)							
1	P-W (1)							
...	...							
95	P-W (95)							

R-W raw data is returned in the format and order found on the media. It is the responsibility of the device driver to de-interleave and perform error detection and correction on the RAW data to make it usable to higher level applications.

Table 43 - P-W Data de-interleaved and error corrected

Bit yte	7	6	5	4	3	2	1	0
0	P	Q	PACK (0)					
1	P	Q	PACK (1)					
...	...							
23	P	Q	PACK (23)					
24	P	Q	PACK (0)					
25	P	Q	PACK (1)					
...	...							
47	P	Q	PACK (23)					
48	P	Q	PACK (0)					
49	P	Q	PACK (1)					
...	...							
71	P	Q	PACK (23)					
72	P	Q	PACK (0)					
73	P	Q	PACK (1)					
...	...							
93	P	Q	PACK (23)					

Drives that cannot return P or Q code with PACK data will return undefined data in the unsupported P or Q bits. Each PACK is generated after 2 contiguous Sub Channel data frames consisting of 24 bytes with 6 bits of PACK data per byte. Each 96 byte Packet consists of 4 Packs of 24 bytes each.

The basic RAW format is shown in Figure 11 below. The data is synchronized with the sub-channel sync patterns S0 and S1. Each group of 6 bits (R-W) is called a "symbol." The symbol following the sub-channel patterns S0 and S1, is the first symbol of the first pack in a packet.

5.1.8.1. Description of Sub-Channels R-W

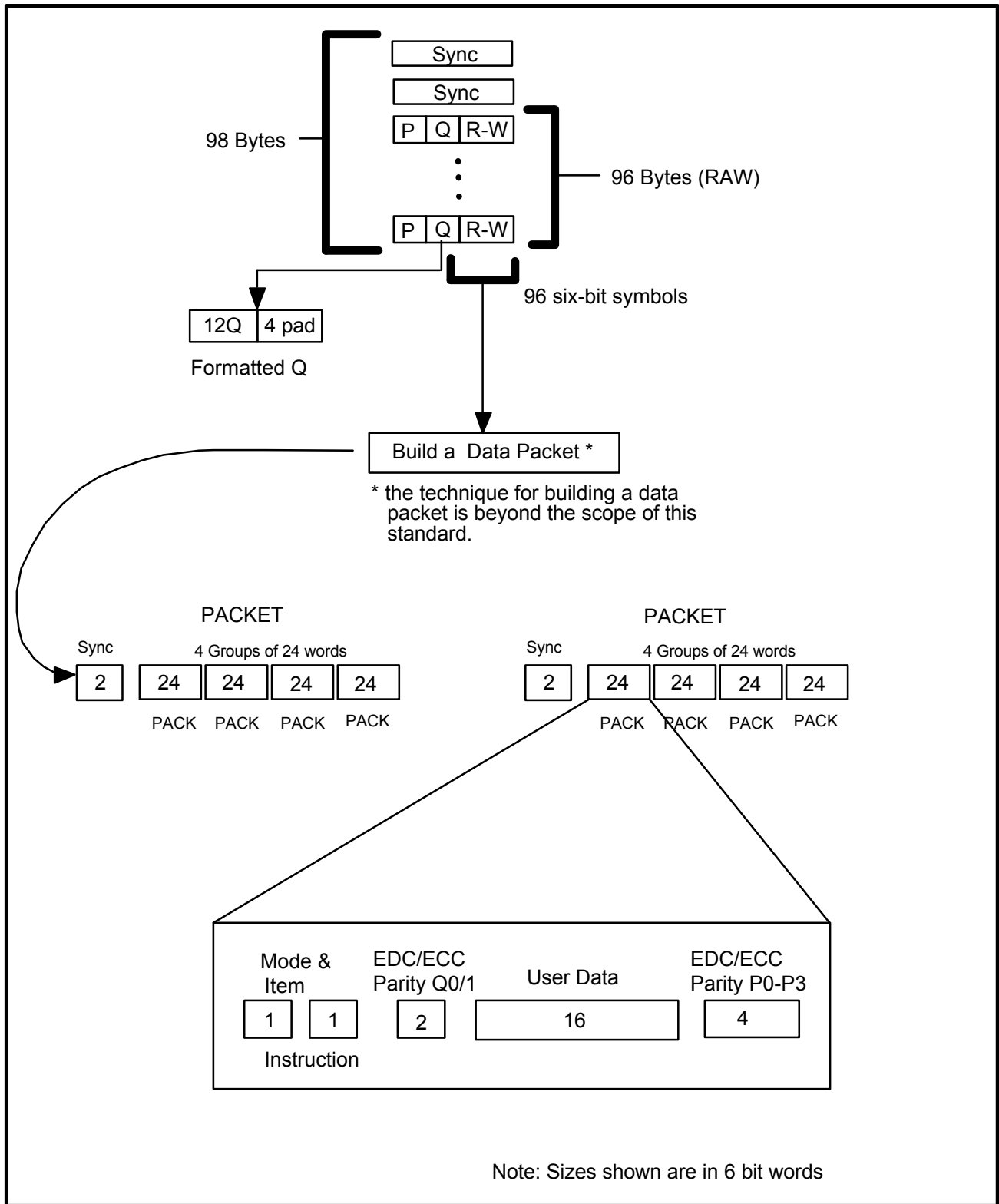

Figure 11 - Read CD Sub-Channel, R-W (100b)

To guard the data in the sub-coding channels R-W, a (24,20) Reed-Solomon Error Correction Code is used. To improve the burst error correction capability, eight way interleaving is added to this error correction system.

The first two symbols in a pack have additional protection with a (4,2) Reed Solomon Error Correction Code. The first symbol of a pack contains a mode-switch of 3 bits and a 3 bit subdivision of mode, called "item." The defined mode-item combinations are listed in Table 44.

**Table 44 - Sub-channel R-W; Allowed mode/item combinations**

Mode	Item	Description
000b	000b	The Zero mode
001b	000b	
	001b	
111b	000b	The user mode
All others		<b>Reserved</b> for future use

The R-W information is returned as part of the "raw" sub-channel data. The lower 6 bits of each of the bytes contain the R-W data. This data follows the format shown in Figure 11. If the Q information needs to be taken from the raw data then it shall not be interleaved.



## 5.1.9. READ CD MSF Command

The READ CD MSF Command described in Table 45 provides a single standard command format for accessing CD data via MSF addressing. This command is generic to all types of CD data formats.

This command returns any of the defined CD data streams, including the headers, EDC, ECC, user data and CD-DA data. Each type of data is enabled via the fields in the READ CD MSF command descriptor block (see Table 45). These fields indicate which information from the CD is to be returned in the data stream. If the bit is cleared, then that particular information is not returned. If all the fields contain zero then no information is returned. This condition shall not be considered an error.

Table 45 - READ CD MSF Command Descriptor Block

Bit Byte	7	6	5	4	3	2	1	0	
0	OPERATION CODE (B9h)								
1	Reserved			Sector Type			Reserved		
2	Reserved								
3	Starting M Field								
4	Starting S Field								
5	Starting F Field								
6	Ending M Field								
7	Ending S Field								
8	Ending F Field								
9	SYNC	Header Codes		User Data	EDC & ECC	Error Fields		Reserved	
10	Reserved					Sub-Channel Selection Bits			
11	Control								

The Starting M field, the Starting S field, and the Starting F field specify the absolute MSF address where the Read operation shall begin. The Ending M field, the Ending S field, and the Ending F field specify the absolute MSF address where the Read operation shall end. All contiguous sectors between the starting and ending MSF addresses shall be read.

A starting MSF address equal to an ending MSF address prevents a read operation. This shall not be considered an error. If the starting MSF address is greater than the ending MSF address, the command shall be terminated with CHECK CONDITION status, ILLEGAL REQUEST.

If the starting address is not found, or if a not ready condition exists, the command shall be terminated with CHECK CONDITION status.

For descriptions of Sector Type field see Table 31.

For a description of all fields in byte 9, and Sub-channel Selection Bits (byte 10), see sub-clause 5.1.8. Read CD Command.

Table 46 - Recommended errors for READ CD MSF Command

Error	Reference
Deferred Errors	Sub-clause A.1
General Errors	Table A.2
Media Access Errors	Table A.3
READ ERROR - LOSS OF STREAMING	Table A.1

## 5.1.10. READ CD RECORDED CAPACITY Command

The READ CD RECORDED CAPACITY command (Table 47) provides a means for the initiator to request information regarding the capacity of the logical unit. This command has the same operation code (25h) as the READ CAPACITY command (see SCSI Primary Commands). The general function is the same but the exact definitions of the returned logical block address is modified to allow returning a possibly inexact value (but one with a known error bound) based on the Table of Contents data.

Table 47 - READ CD RECORDED CAPACITY Command Descriptor Block

Bit Byte	7	6	5	4	3	2	1	0
0	OPERATION CODE (25h)							
1	RESERVED			Reserved				RELADR
2	(MSB) Logical Block Address (LSB)							
3								
4								
5								
6	Reserved							
7	Reserved							
8	Reserved							PMI
9	Control							

The RELADR bit shall be set to zero.

READ CD RECORDED CAPACITY response data shall be the logical block address and block length (in bytes) of the last valid logical block of the logical unit for seek operations. The logical block address returned shall be greater than or equal to the last readable or playable block in the last complete session. If greater, this address may be in a transition area beyond the last valid logical block for read or audio play operations. The logical block address in the command descriptor block shall be set to zero for this option.

The PMI bit shall be set to zero. Eight bytes of READ CD RECORDED CAPACITY data (Table 48) shall be returned in response to the command.

Table 48 - READ CD RECORDED CAPACITY data format

Bit Byte	7	6	5	4	3	2	1	0
0	(MSB) Logical Block Address (LSB)							
...								
3								
4	(MSB) Block Length (LSB)							
...								
...								
7								

The returned Logical Block Address shall be the last sector in the last complete session.

The block length shall be reported as 2048. A block length of 512 is obsolete..

Table 49 - Recommended errors for READ CD RECORDED CAPACITY Command

Error	Reference
Deferred Errors	Sub-clause A.1
General Errors	Table A.2
Media Access Errors	Table A.3

## 5.1.11. READ HEADER Command

The READ HEADER command (Table 50) requests that the device return the CD data block address header of the requested logical block.

Table 50 - READ HEADER Command Descriptor Block

Bit Byte	7	6	5	4	3	2	1	0
0	OPERATION CODE (44h)							
1	RESERVED			Reserved			MSF	Reserved
2	(MSB) Logical Block Address (LSB)							
3								
4								
5								
6	Reserved							
7	(MSB) Allocation Length (LSB)							
8								
9	Control							

If the MSF bit is zero, the read header LBA parameter list, see Table 51 defines the CD data block address header of the requested logical block. If the MSF bit is one, the read header MSF parameter list (see Table 53) defines the CD data absolute address of the requested logical block.

The logical block address field specifies the logical block where the read header operation shall begin. If the logical block size is other than the physical block size, it shall be mapped into the appropriate physical block from which the data would have been read.

The READ HEADER data format (Table 51) defines the CD data block address header of the requested logical block.

Table 51 - READ HEADER LBA data format

Bit Byte	7	6	5	4	3	2	1	0
0	CD Data Mode							
1	Reserved							
2	Reserved							
3	Reserved							
4	(MSB) Logical Block Address (LSB)							
5								
6								
7								

The CD data mode field specifies the CD-ROM data mode of the logical blocks in this sector of data. The values in this field are defined in Table 52.

Table 52 - CD Data Mode field

CD Data Mode	CD Sector Formats
00h	Mode 0 or Audio
01h	Mode 1
02h	Mode 2
03h - FFh	Reserved

See Figure 8 for the CD sector format definition.

Table 53 - READ HEADER MSF data format

Bit Byte	7	6	5	4	3	2	1	0
0	CD Data Mode							
1	Reserved							
2	Reserved							
3	Reserved							
4	Reserved							
5	M							
6	S							
7	F							

Table 54 - Recommended errors for READ HEADER command

Error	Reference
Deferred Errors	Sub-clause A.1
General Errors	Table A.2
Media Access Errors	Table A.3

### 5.1.12. READ SUB-CHANNEL Command

The READ SUB-CHANNEL command (Table 55) requests that the target return the requested sub-channel data plus the state of audio play operations.

NOTE: Sub-channel data returned by this command may be from the last appropriate sector encountered by a current or previous media accessing operation. When there is no current audio play operation, the target may access the media to read the sub-channel data. The target is responsible for ensuring that the data returned is current and consistent.

**Table 55 - READ SUB-CHANNEL Command Descriptor Block**

Bit	7	6	5	4	3	2	1	0
Byte								
0	OPERATION CODE (42h)							
1	RESERVED			Reserved			MSF	Reserved
2	Reserved	SUBQ	Reserved					
3	Sub-Channel Parameter List							
4	Reserved							
5	Reserved							
6	Track Number (Hex)							
7	(MSB)				Allocation			
8					Length (LSB)			
9	Control							

If the MSF bit is zero, the read header LBA parameter list, see Table 51 defines the CD data block address header of the requested logical block. If the MSF bit is one, the read header MSF parameter list (see Table 53) defines the CD data absolute address of the requested logical block.

The sub Q bit set to one requests that the target return the Q sub-channel data. The sub Q bit set to zero requests that no sub-channel data be returned. See 5.1.12.1. This shall not be considered an error.

The sub-channel parameter list (Table 56) field specifies the returned sub channel data.

**Table 56 - Sub-channel parameter list codes**

Format Code	Returned Data
00h	Reserved
01h	CD current position
02h	Media Catalogue number (UPC/bar code)
03h	Track International standard recording code (ISRC)
04h - EFh	Reserved
F0h - FFh	Vendor specific

The Track Number field specifies the track number from which ISRC data is read. This field shall have a value between 01h and 63h (99 bcd), and is valid only when the sub-channel parameter list field is 03h. In this case, the target returns ISRC data for this track. This field may contain 00h when the Format code is not 03h.

#### 5.1.12.1. Sub-Channel Data Header

The Sub-Channel data header format (Table 57) is four bytes. If the Sub Q bit is zero, in the command, the target shall return only the sub-channel data header. In this case, the sub-channel data length is 0.

Table 57 - Sub-Q Channel Data Header Format

Bit Byte	7	6	5	4	3	2	1	0
0	Reserved							
1	Audio Status							
2	(MSB) Sub-Channel							
3	Data Length (LSB)							

The audio status field indicates the status of audio play operations. The audio status values are defined in Table 58. Devices which do not support audio play operations shall always report 00h.

For devices which support audio operations: The initial value for audio status is 15h. Audio status values 13h and 14h return information on previous audio operations. When audio play stops due to an error and the IMMED bit in the CD Audio Control Page (see Table 97) is set to one, the device shall report 14h in this audio status byte and shall report no deferred error.

Table 58 - Audio status codes

Status	Description
00h	Audio status byte not supported or not valid
01h - 10h	Reserved
11h	Audio play operation in progress
12h	Audio play operation paused
13h	Audio play operation successfully completed
14h	Audio play operation stopped due to error
15h	No current audio status to return
16h - FFh	Reserved

The sub-channel data length field specifies the length in bytes of the following sub-channel data block. A sub-channel data length of zero indicates that no sub-channel data block is included in the returned data. Sub-channel data length does not include the sub channel header.

#### 5.1.12.2. Sub-Channel Data Format (01h), CD current position

Table 59 defines the response data format for the CD current position data format.

Table 59 - CD current position data format

Bit Byte	7	6	5	4	3	2	1	0
0	Sub-Channel Data Format Code (01h)							
1	ADR				CONTROL			
2	TRACK NUMBER							
3	INDEX NUMBER							
4	(MSB) Absolute CD Address							
7	(LSB)							
8	(MSB) Track Relative CD Address							
11	(LSB)							

The ADR field gives the type of information encoded in the Q sub-channel of this block, as shown in Table 60.

**Table 60 - ADR Q sub-channel field**

ADR Code	Description
00h	Q sub-channel mode information not supplied
01h	Q sub-channel encodes current position data (i.e., track, index, absolute address, relative address)
02h	Q sub-channel encodes media catalogue number
03h	Q sub-channel encodes ISRC
04h - 0Fh	Reserved

The control field is defined in Table 61.

The bits of the control field (except for the copy bit) can change during an actual pause (X=00) of at least 2 seconds and during the lead-in area only.

**Table 61 - Q sub-channel control field**

field	Definitions
00x0b	2 audio channels without pre-emphasis
00x1b	2 audio channels with pre-emphasis of 50/15 $\mu$ s
10x0b	audio channels without pre-emphasis (reserved in CD-R/RW)
10x1b	audio channels with pre-emphasis of 50/15 $\mu$ s (reserved in CD-R/RW)
01x0b	Data track, recorded uninterrupted
01x1b	Data track, recorded incremental
11xxb	reserved
xx0xb	digital copy prohibited
xx1xb	digital copy permitted

The Track Number field contains the current track number.

The Index Number field contains the current index number.

The Absolute CD Address field gives the current location relative to the logical beginning of the media. If the MSF bit, (Table 55) is zero, this field is an LBA. If the MSF bit is one, the address is MSF. See sub-clause 4.1.7. for a definition of the MSF field.

The Track Relative CD Address field gives the current location relative to the logical beginning of the current track. If the MSF bit is zero, this field is a track relative LBA. (If the current block is in the pre-gap area of a track, this will be a negative value, expressed as a two's-complement number.) If the MSF bit in the CDB is set to one, this field is the relative MSF address from the Q sub-channel.

The control data and current position data is obtained from the Q sub-channel information of the current block. Identification data may be reported that was obtained from a previous block. If identification data is reported, the data shall be valid for the sector addressed by the current position data.

- a) If an audio play operation is proceeding in the background, position data for the last sector played shall be reported.
- b) In other cases, for instance after a READ command, the target may either report position data for the last sector processed for that operation or may report position data from the sector at the current read head position.

Note: When the type of information encoded in the Q sub-channel of the current sector is the media catalog number or ISRC, the track, index, and address fields should be extrapolated from the previous sector.



## 5.1.12.3. Sub-Channel Data Format (02h), Media Catalogue Number

With a Sub-channel format code of 02h the data returned is the Media Catalog Number. The Media Catalog field contains the identifying number of this media is expressed in ASCII. A value in this field of all ASCII zeros indicates that the media catalogue number is not supplied. Table 62 defines the media catalogue number data format.

Table 62 - Media Catalogue Number data format

Bit Byte	7	6	5	4	3	2	1	0
0	Sub-Channel Data Format Code (02h)							
1	Reserved							
2	Reserved							
3	Reserved							
4	Media Catalogue Number (MCN)							
...								
...								
...								
19								

If media catalogue number data is found, the MCVAl bit is set to one. If MCN data is not detected, the MCVAl bit is set to zero to indicate the media catalogue number field is invalid.

Media Catalogue Number (see Table 63) data returned in bytes 4 through 19 by this command with sub-channel data format field code 02h may be from any block that has MCN Q sub-channel data. See Table 3 and sub-clause 4.1.3.2.2.

Table 63 - MCN Format of Data Returned

Byte	Char	Bit 7	Bit 6	Bit 5	Bit 4	Bit 3	Bit 2	Bit 1	Bit 0
0		MCVAL	Reserved						
1	N1	N1 (Most significant)							
2	N2	N2							
3	N3	N3							
...	...	...							
12	N12	N12							
13	N13	N13 (Least significant)							
14		Zero							
15		AFRAME							

All Nxx bytes are ASCII.

The MCVAl bit when set to one, indicates the Media Catalog Number field is valid.

Zero field shall return 00h.

AFRAME may return the frame number in which the MCN was found. This shall be a value from 00h to 4Ah. All other values are reserved.

## 5.1.12.4. Sub-Channel Data Format (03h), Track International Standard Recording Code

The track ISRC field contains the identifying number of this media according to the ISRC standards (DIN-31-621) expressed in ASCII. Table 64 defines the track international standard recording code data format. A unique ISRC may exist for each track.

Table 64 - Track International Standard Recording Code data format

Bit Byte	7	6	5	4	3	2	1	0	
0	Sub-Channel Data Format Code (03h)								
1	ADR				CONTROL				
2	Track Number								
3	Reserved								
4	(MSB)	Track International Standard Recording Code (ISRC)							
19								(LSB)	

If ISRC data is detected, the TCVAL bit (see Table 65) is set to one. If ISRC data is not detected, the TCVAL bit is set to zero to indicate the ISRC field is invalid.

The ADR (Table 60) and Control fields (Table 61) shall be returned from the ADR and Control fields on the media.

The Track Number shall indicate the track for which the ISRC was requested.

Track ISRC data (see Table 65) may be from any block in the specified track that has ISRC data. When ADR field is 3 (0011), it is used to assign a unique number to an audio track. This is done by means of the ISRC which is 12 characters long (represented by I1 to I12, see Table 3 and sub-clause 4.1.3.2.3.). The ISRC shall only change immediately after the TNO has been changed.

ISRC data returned is encoded as ASCII characters. The format of the data is defined in Table 65.

Table 65 - ISRC Format of Data Returned

Byte	Char	Bit 7	Bit 6	Bit 5	Bit 4	Bit 3	Bit 2	Bit 1	Bit 0
0		TCVAL	Reserved						
1	I1	I1 (Country Code)							
2	I2								
3	I3	I3 (Owner Code)							
4	I4								
5	I5	I6 (Year of Recording)							
6	I6								
7	I7	I8 (Serial Number)							
8	I8								
9	I9	I9							
10	I10								
11	I11	I10							
12	I12								
13		Zero							
14		AFRAME							
15		Reserved							

All bytes are specified in ASCII. The following translation is specified for devices:

ASCII	Hex	MEDIA
'0' - '9'	30h - 39h	00 - 09h
'@' - 'o'	40h - 6Fh	10h - 3Fh

The following codes shall be valid for the above fields (Table 65):

- a. Country Code: 'A' - 'Z' (41h - 5Ah)
- b. Owner Code: '0' - '9' and 'A' - 'Z' (30h - 39h, 41h - 5Ah)
- c. Year of Recording: '0' - '9' (30h - 39h)
- d. Serial Number: '0' - '9' (30h - 39h)

Zero field shall return 00h.

AFRAME may return the frame number in which the MCN was found. This shall be a value from 00h to 4Ah. All other values are reserved.

Table 66 - Recommended errors for READ SUB-CHANNEL command

Error	Reference
Deferred Errors	Sub-clause A.1
General Errors	Table A.2
Media Access Errors	Table A.3
AUDIO PLAY OPERATION IN PROGRESS	Table A.1
AUDIO PLAY OPERATION PAUSED	Table A.1
AUDIO PLAY OPERATION SUCCESSFULLY COMPLETED	Table A.1
AUDIO PLAY OPERATION STOPPED DUE TO ERROR	Table A.1
NO CURRENT AUDIO STATUS TO RETURN	Table A.1

## 5.1.13. READ TOC/PMA/ATIP Command

The READ TOC/PMA/ATIP Command (Table 67) requests that the target transfer data from the Table of Contents, the Program Memory Area (PMA), and the Absolute Time in Pre-Grove (ATIP).

Table 67 - READ TOC/PMA/ATIP Command Descriptor Block

Bit Byte	7	6	5	4	3	2	1	0
0	OPERATION CODE (43h)							
1	Reserved			Reserved			MSF	Reserved
2	Reserved				Format			
3	Reserved							
4	Reserved							
5	Reserved							
6	Track/Session Number (Hex)							
7	(MSB) Allocation Length							
8	(LSB)							
9	Control							

See sub-clause 4.1.7. for a description of the MSF bit.

The Format field is defined in Table 68.

Table 68 - Format Field

Format	Source	Optional/ Mandatory	Description	Track/ Session Usage
0000b	TOC	M	The Track/Session Number field specifies starting track number for which the data will be returned. For multi-session discs, this command will return the TOC data for all sessions and for Track number AAh only the lead-out area of the last complete session. See Table 70.	Track
0001b	Session Info	M	This format returns the first complete session number, last complete session number and last complete session starting address. In this format, the Track/Session Number field is reserved and should be set to 00h. NOTE: This format provides the initiator access to the last finalized session starting address quickly. See Table 71.	Reserved
0010b	Full TOC	M	This format returns all Q sub-code data in the lead-in(TOC) areas starting from a session number as specified in the Track/Session Number field. In this mode, the drive will support Q Sub-channel POINT field value of A0h, A1h, A2h, Track numbers, B0h, B1h, B2h, B3h, B4h, C0h, and C1h. See Table 72.	Session
0011b	PMA	O	This format returns all Q sub-code data in the PMA area. In this format, the Track/Session Number field is reserved and shall be set to 00h. See Table 76.	Reserved
0100b	ATIP	O	This format returns ATIP data. In this format, the Track/Session Number field is reserved and shall be set to 00h. See Table 77.	Reserved
All Other Format Codes			Reserved.	Reserved

The Track/Session Number field specifies the starting track number for which the data shall be returned. The data is returned in contiguous ascending track number order. A value of AAh requests that the starting address of the lead-out

area be returned. If this value is zero, the Table of Contents data shall begin with the first track or session on the medium.

If the Track/Session Number field is not valid for the currently installed medium, the command shall be terminated with CHECK CONDITION status. The sense key shall be set to ILLEGAL REQUEST and the additional sense code set to INVALID FIELD IN CDB.

When a Read TOC/PMA/ATIP command is presented for a CD-R/RW media, where the first TOC has not been recorded (no complete session) and the Format codes 0000b, 0100b, or 1000b are specified, this command shall be rejected with an INVALID FIELD in COMMAND PACKET. Devices that are not capable of reading an incomplete session on CD-R/RW media shall report NOT READY, MEDIA FORMAT NOT COMPATIBLE.

#### 5.1.13.1. READ TOC Response parameter list, general definition

The response parameter list (see Table 3) indicates the general description of the response data to the Read TOC/PMA/ATIP command. Each descriptor field is format specific and is defined in the appropriate format sub-clause.

**Table 69 - READ TOC/PMA/ATIP parameter list, general definition**

Bit Byte	7	6	5	4	3	2	1	0
0	(MSB) Data Length							
1	(LSB)							
2	First Track/Session/Reserved Field(Hex)							
3	Last Track/Session/Reserved Field(Hex)							
Parameter List Descriptor(s)								
0	Descriptor data , format specific							
:								
:								
n								

The Data Length indicates the length, in bytes, of the parameter list descriptor data.

The Track/Session/Reserved Field is format specific and indicates the location, if any, of the information in the parameter list descriptors.

Descriptor data fields are format specific. The definitions of the bytes are described in each format sub-clause.

## 5.1.13.2. TOC/PMA/ATIP Response Data Format 0000b

The response data consist of four header bytes and zero or more track descriptors. The response data is dependent upon the format specified in the format field of the CDB. The response data returned for Format 0000b is specified in Table 70.

Table 70 - READ TOC/PMA/ATIP response data (Format = 0000b)

Bit Byte	7	6	5	4	3	2	1	0
0	(MSB) TOC Data Length							
1	(LSB)							
2	First Track Number(Hex)							
3	Last Track Number(Hex)							
TOC Track Descriptor(s)								
0	Reserved							
1	ADR				CONTROL			
2	Track Number(Hex)							
3	Reserved							
4	(MSB)							
Logical Block Address								
7	(LSB)							

The TOC data length indicates the length in bytes of the following TOC data. The TOC data length value does not include the TOC data length field itself. This value is not modified when the allocation length is insufficient to return all of the TOC data available.

The First Track Number field indicates the first track number in the first complete session Table of Contents.

The Last Track Number field indicates the last track number in the last complete session Table of Contents before the lead-out.

The ADR field gives the type of information encoded in the Q sub-channel of the block where this TOC entry was found. The possible ADR values are defined in Table 60.

The Control Field indicates the attributes, of the track, see Table 61.

The Track Number field indicates the track number for which the data in the TOC track descriptor is valid. A track number of AAh indicates that the track descriptor is for the start of the lead-out area.

The Logical Block Address contains the address of the first block with user information for that track number as read from the Table of Contents. An MSF bit of zero indicates that the Logical Block Address field contains a logical block address. An MSF bit of one indicates the Logical Block Address field contains an MSF address (see sub-clause 4.1.6).

## 5.1.13.3. TOC/PMA/ATIP Response Data Format 0001b

The response data returned for Format 0001b is specified in Table 71.

**Table 71 - READ TOC/PMA/ATIP response data (Format = 0001b)**

Bit Byte	7	6	5	4	3	2	1	0
0	(MSB) TOC Data Length							
1	(LSB)							
2	First Complete Session Number (Hex)							
3	Last Complete Session Number (Hex)							
TOC Track Descriptor								
0	Reserved							
1	ADR				CONTROL			
2	First Track Number In Last Complete Session (Hex)							
3	Reserved							
4	(MSB)							
	Logical Block Address of First Track in Last Session							
7	(LSB)							

The TOC Data Length specifies the length in bytes of the available session data. The TOC Data Length value does not include the TOC Data Length field itself. This value is not modified when the allocation length is insufficient to return all of the session data available.

The First Complete Session Number is set to one.

The Last Complete Session Number indicates the number of the last complete session on the disc. The Last Complete Session Number shall be set to one for a single session disc or if the device does not support multi-session discs.

The ADR field gives the type of information encoded in the Q sub-channel of the block where this TOC entry was found. The possible ADR values are defined in Table 60.

The Control Field indicates the attributes of the track. The possible control field values are defined in Table 61.

First Track Number In Last Complete Session returns the first track number in the last complete session.

The Logical Block Address contains the address of the first block with user information for the first track of the last session, as read from the Table of Contents. An MSF bit of zero indicates that the Logical Block Address field contains a logical block address. An MSF bit of one indicates the Logical Block Address field contains an MSF address (see sub-clause 4.1.7.).



## 5.1.13.4. TOC/PMA/ATIP Response Data Format 0010b

The response data returned for Format 0010b is specified in Table 72.

**Table 72 - READ TOC/PMA/ATIP response data (Format = 0010b)**

Bit Byte	7	6	5	4	3	2	1	0
0	(MSB) TOC Data Length							
1	(LSB)							
2	First Complete Session Number (Hex)							
3	Last Complete Session Number (Hex)							
TOC Track Descriptor(s)								
0	Session Number (Hex)							
1	ADR				CONTROL			
2	TNO							
3	POINT							
4	Min							
5	Sec							
6	Frame							
7	Zero							
8	PMIN							
9	PSEC							
10	PFRAME							

Multiple TOC Track Descriptors may be returned.

For Format field of 1000b, the device shall return TOC data for Q sub-channel modes 1 and 5 (except mode 5, point 1 through 40) in the lead-in area.

The TOC Data Length specifies the length in bytes of the available TOC data. The TOC Data Length value does not include the TOC Data Length field itself. This value is not modified when the allocation length is insufficient to return all TOC data available.

The First Complete Session Number shall be set to one.

The Last Complete Session Number indicates the number of the last complete session on the disc. The Last Complete Session Number is set to one for a single session disc or if the device does not support multi-session discs.

The ADR field gives the type of information encoded in the Q sub-channel of the block where this TOC entry was found. The possible ADR values are defined in Table 60.

The Control Field indicates the attributes of the track. The possible control field values are defined in Table 61.

Entries in bytes 2 through 10 of the descriptors (TNO, POINT, MIN, SEC, FRAME, Zero) shall be converted to hex by the device if the media contains a value between 0 and 99bcd. For definition of these byte see Table 73.

The returned TOC data of a multi-session disc is arranged in ascending order of the session number with duplicates removed. The TOC data within a session is arranged in the order of Q Sub-channel POINT field value of A0h, A1h, A2h, Track Numbers, B0h, B1h, B2h, B3h, B4h, C0h, and C1h.

The TOC Track Descriptor format in the lead-in area of the TOC is described in Table 73.

Table 73 - TOC Track Descriptor Format, Q sub-channel

CTRL	ADR	TNO (hex)	POINT (hex)	MIN (hex)	SEC (hex)	FRAME (hex)	ZERO (hex)	PMIN (hex)	PSEC (hex)	PFRAME (hex)
4 or 6	1	00	01-63	ATIME (Absolute time)			00	Start position of track		
4 or 6	1	00	A0	ATIME (Absolute time)			00	Frist Track Number	Disc Type	00
4 or 6	1	00	A1	ATIME (Absolute time)			00	Last Track Number	00	00
4 or 6	1	00	A2	ATIME (Absolute time)			00	Start position of lead-out		
4 or 6	5	00	B0	Start time of next possible program in the Recordable Area of the disc			# of pointers in Mode 5	Maximum start time of outer-most lead-out area in the Recordable Area of the disc		
4 or 6	5	00	B1	00	00	00	00	# of skip interval Pointers (N<=40)	# of skip Track Pointers (N<=21)	00
4 or 6	5	00	B2-B4	Skip #	Skip #	Skip #	Skip #	Skip #	Skip #	Skip #
4 or 6	5	00	01-40	Ending time for the interval that should be skipped			Resrv'd	Start time for interval that should be skipped on playback		
4 or 6	5	00	C0	optimum recording power	Reserved	Reserv'd	Reserved	Start time of the first lead-in Area of the disc		
4 or 6	5	00	C1	Copy of information from A1 point in ATIP.						

All of the TOC Track Descriptors, in Table 73, are further define in sub-clause 4.1.3.2. Q sub-channel information formats

.The POINT Field (Table 74) defines various types of information within the TOC lead-in area.

Table 74 - POINT Field

ADR	POINT Field	Description
1	01-63h	Track number references
1	A0h	First Track number in the program area
1	A1h	Last Track number in the program area
1	A2h	Start location of the lead-out area
5	01-40h	Skip Interval Pointers
5	B0h	Used to Identify a Multisession Disc (Photo CD) Contains start time of next possible program area
5	B1h	Number of skip interval pointers & Skip track assignments
5	01-40h	Skip Interval Pointers
5	B2-B4h	Skip Track Assignment Pointers
5	C0h	Start time of first lead-in area of disc (This only exists in the first lead-in area)
5	C1h	Copy of information from additional area 1 in ATIP.

The Disc Type field (see Table 75) indicates the type of disc inserted.

**Table 75 - Disc Type Byte Format**

Value	Description
00h	CD-DA or CD Data with first track in Mode 1
10h	CD-I disc
20h	CD data XA disc with first track in Mode 2

The definition for the Control Field in the Q sub-channel is in Table 61. See Figure 3.

## 5.1.13.5. TOC/PMA/ATIP Response Data Format 0011b

The response data returned for Format 0011b is specified in Table 76.

**Table 76 - READ TOC/PMA/ATIP response data (Format = 0011b)**

Bit Byte	7	6	5	4	3	2	1	0
0	(MSB) PMA Data Length							
1	(LSB)							
2	Reserved							
3	Reserved							
PMA Descriptor(s)								
0	Reserved							
1	ADR				CONTROL			
2	TNO							
3	POINT							
4	Min							
5	Sec							
6	Frame							
7	Zero							
8	PMIN							
9	PSEC							
10	PFRAME							

Multiple PMA Descriptors may be returned.

The returned PMA descriptors are arranged in the order found in the PMA, with duplicates removed.

The PMA Data Length indicates the length in bytes of the available PMA data. The PMA Data Length value does not include the PMA Data Length field itself. This value is not modified when the allocation length is insufficient to return all PMA data available. This value is set to 2 plus eleven times the number of descriptors read.

Entries in bytes 2 through 10 of the descriptors (TNO, POINT, MIN, SEC, FRAME, Zero) shall be converted to hex by the device if the media contains a value between 0 and 99bcd. For definition of these bytes see Table 73. The TOC Track Descriptors are further defined in sub-clause 4.1.3.2. Q sub-channel information formats

## 5.1.13.6. TOC/PMA/ATIP Response Data Format 0100b

The response data returned for Format 0100b is specified in Table 77.

**Table 77 - READ TOC/PMA/ATIP response data (Format = 0100b)**

Bit Byte	7	6	5	4	3	2	1	0
0	(MSB) ATIP Data Length							
1								(LSB)
2	Reserved							
3	Reserved							
ATIP Descriptor								
4	1	Indicative Target Writing Power			Reserved	Reference Speed		
5	0	URU	Reserved					
6	1	Disc Type	Disc Sub-Type			A1	A2	A3
7	Reserved							
8	ATIP Start Time of lead-in (Min)							
9	ATIP Start Time of lead-in (Sec)							
10	ATIP Start Time of lead-in (Frame)							
11	Reserved							
12	ATIP Last Possible Start Time of lead-out (Min)							
13	ATIP Last Possible Start Time of lead-out (Sec)							
14	ATIP Last Possible Start Time of lead-out (Frame)							
15	Reserved							
16	0	Lowest Usable CLV Recording Speed			Highest Usable CLV Recording Speed			
17	0	Power Multiplication Factor p			Target y value of the Modulation/Power function		Reserved	
18	1	Recommended Erase/Write Power Ratio ( $P_{eo}/W_{eo}$ )			Reserved			
19	Reserved							
20-22	A2 Values							
23	Reserved							
24-26	A3 Values							
27	Reserved							

ATIP Data Length specifies the number of bytes to be transferred in response to the command. The ATIP Data Length value does not include the data length field itself. This value is not modified when the allocation length is insufficient to return all of the ATIP data available.

Indicative Target Writing Power Field - encoded information indicating the media's recommended initial laser power setting. The meaning of these bits varies between CD-R and CD-RW media.

Reference Speed Field - encoded information indicating the recommended write speed for the media. 00h = reserved. 01h - 2X recording, 02h-07h are reserved. Valid only for CD-RW media.

The URU (Unrestricted Use Disc) bit, when set to one, indicates that the mounted CD-R/RW disc is defined for unrestricted use. When the Unrestricted Use Disc bit is set to zero, the mounted CD-R/RW disc is defined for restricted

use. To record data to the mounted disc the appropriate Host Application code shall be set through the Write Parameters Page. A Host Application Code of zero may be used to indicate a restricted use disc - general purpose.

Disc Type - zero indicates CD-R media; one indicates CD-RW media.

Disc Sub-Type - shall be set to zero.

A1 - when set to one, indicates that bytes 16-18 are valid.

A2 - when set to one, indicates that bytes 20-22 are valid.

A3 - when set to one, indicates that bytes 24-26 are valid.

ATIP Start time of Lead-in (min,sec,frame) - the start time of the lead-in. The value is read from ATIP and returned in hex format. Legal values for the M field are 50h through 63h.

ATIP Last Possible Start Time of Lead-out (min,sec,frame) - the last possible start time of lead-out. The value is read from ATIP and returned in hex format. Valid values for the M field are 0 through 4Fh.

Lowest Usable CLV Recording Speed (see Table 77) - valid only when A1 = 1.

**Table 78 - Lowest CLV Recording Speeds**

Value	Recording Speed
000b	Reserved
001b	2X
010b - 111b	Reserved

Highest Usable CLV Recording Speed - valid only when A1 = 1.

**Table 79 - Highest CLV Recording Speeds**

Value	Recording Speed
000b	Reserved
001b	2X
010b	4X
011b	6X
100b	8X
101b - 111b	Reserved

The following fields reported as recorded in ATIP, contain information that is beyond the scope of this standard.

Power Multiplication Factor p field.

Target y value of the Modulation/Power function field.

Recommended Erase/Write Power Ratio ( $P_{eo}/W_{eo}$ ) field.

A2 Values - Reserved

A3 Values - Reserved

**Table 80 - Recommended errors for READ TOC/PMA/ATIP Command**

Error	Reference
Deferred Errors	Sub-clause A.1
General Errors	Table A.2
Media Access Errors	Table A.3
AUDIO PLAY OPERATION IN PROGRESS	Table A.1

## 5.1.14. SCAN Command

The scan command requests a fast-forward or fast-reverse scan operation starting from the Scan Starting Address. The device shall respond to this command by scanning all the way to the end of the last audio track on the media.

Like the PLAY AUDIO command, the SCAN command shall terminate the scan at the last audio track or upon receipt of a STOP PLAY/SCAN command. Upon receipt of the STOP PLAY/SCAN command the device shall set the current address to the last address of data read from the media by the scan operation. Subsequent Audio Play commands shall cause the device to begin playing at the location last output by the SCAN command. If the drive receives a PAUSE/RESUME Command with the resume bit clear, the drive shall pause. After that, if the drive receives a PAUSE/RESUME Command with the resume bit set, the drive shall resume audio play, not scan, from the address where the audio pause occurred.

If the drive receives a SCAN command during play or pause, the drive shall stop play or pause and perform Scan.

If the drive encounters a data track, it shall terminate the scan.

Upon receipt of a READ SUB-CHANNEL Command during scan, the drive shall return an Audio Status of 11h (Audio Play operation in Progress).

The initiator is required to issue PLAY AUDIO command immediately following a STOP PLAY/SCAN command to resume the play audio operation at normal speed.

Table 81 - SCAN Command Descriptor Block

Bit Byte	7	6	5	4	3	2	1	0
0	OPERATION CODE (BAh)							
1	Reserved			Direct	Reserved			RELADR
2	(MSB) Scan Starting Address Field (LSB)							
3								
4								
5								
6								
7	Reserved							
8	Reserved							
9	Type			Reserved				
10	Reserved							
11	Control							

If the DIRECT bit is set to zero, the device shall perform a fast-forward scan operation. A DIRECT bit of one causes a fast-reversed scan operation.

The RELADR bit shall be set to zero.

The Scan Starting Address specifies the address at which the audio fast scan operation shall begin. The Type field specifies the format of the address contained in the Scan Starting Address Field. Table 82 describes the type field bits.

Table 82 - Type field bit definitions

Bits 7 -6	Address Type
0 0	Logical block address format
0 1	MIN, SEC, and FRAME format (MSF)
1 0	Track Number (TNO) format
1 1	Reserved

With a Type field of 00h the Scan Starting address field specified in command bytes 2-5 are defined in Table 83.

Table 83 - Scan starting address field format-logical blocks

Bit Byte	7	6	5	4	3	2	1	0
2	(MSB) Scan Starting Logical Block Address Field (LSB)							
3								
4								
5								

With a Type field of 01h, bytes 2-5 specify the MSF address of the starting sector. See Table 84 below.

Table 84 - Scan Starting Address format - MIN, SEC, FRAME format

Bit Byte	7	6	5	4	3	2	1	0
2	Reserved							
3	CD-Absolute Time (MIN)							
4	CD-Absolute Time (SEC)							
5	CD-Absolute Time (FRAME)							

The MIN, SEC and FRAME fields specify the relative running time from the beginning of the disc. The MIN field has a range of 00d to 99d (00h to 63h). The SEC field ranges from 00d to 59d (00h to 3Bh). The FRAME field has a range of 00h to 74d (00h to 4Ah). All MSF fields shall be binary

With a Type field of 10h, bytes 2 - 5 specify a starting address of a specific Track Number (TNO). See Table 85 below

Table 85 - Scan Starting Address Format-Track Number (TNO)

Bit Byte	7	6	5	4	3	2	1	0
2	Reserved							
3	Reserved							
4	Reserved							
5	Track Number							

The track number field specifies the track number in binary at which the scan operation will begin. This field has a range of 01h to 63h.



Table 86 - Recommended errors for SCAN operation

Error	Reference
Deferred Errors	Sub-clause A.1
General Errors	Table A.2
Media Access Errors	Table A.3

## 5.1.15. SET CD SPEED Command

The SET CD SPEED (Table 87) command provides a means for the initiator to set the spindle speed to be used while reading CD data. Note that PLAY commands will not use the speed set by this command.

Table 87 - SET CD SPEED Command Descriptor Block

Bit Byte	7	6	5	4	3	2	1	0
0	OPERATION CODE (BBh)							
1	Reserved				Reserved			
2	(MSB) Drive Read Speed (kbytes/sec)							
3	(LSB)							
4	(MSB) Drive Write Speed (kbytes/sec) (CD-R/RW only)							
5	(Reserved for CD-ROM) (LSB)							
6	Reserved							
7	Reserved							
8	Reserved							
9	Reserved							
10	Reserved							
11	Control							

The Drive Read Speed and Write Speed parameters contain the requested Data rates the drive should use. The device may choose to select the speed specified or any slower rate. A value of FFFFh will set the Drive Read Speed or the Drive Write Speed to the maximum supported. Requesting a speed faster than the drive supports shall not generate an error. The actual speed set is returned in the Capabilities Mode Sense page. (See Table 103 - CD Capabilities and Mechanical Status Page).

Table 88 - Recommended errors for SET CD SPEED Command

Error	Reference
Deferred Errors	Sub-clause A.1
General Errors	Table A.2
Media Access Errors	Table A.3

## 5.1.16. STOP PLAY/SCAN Command

The STOP PLAY/SCAN (Table 89) Command stops playback of CD audio commands.

**Table 89 - STOP PLAY/SCAN Command Descriptor Block**

Bit Byte	7	6	5	4	3	2	1	0
0	OPERATION CODE (4Eh)							
1	Reserved			Reserved				
2	Reserved							
3	Reserved							
4	Reserved							
5	Reserved							
6	Reserved							
7	Reserved							
8	Reserved							
9	Control							

Issuing a Stop Play/Scan command while the drive is scanning shall result in continuation of the play command. Issuing a Stop Play/Scan command while the drive is paused shall stop the play command.

Issuing a Stop Play/Scan command when no play operation is in progress shall not be considered an error.

Figure 12 provides an overview of the terminate sequences performed by the Stop Play commands.

**Table 90 - Recommended errors for STOP PLAY/SCAN Command**

Error	Reference
Deferred Errors	Sub-clause A.1
General Errors	Table A.2
Media Access Errors	Table A.3

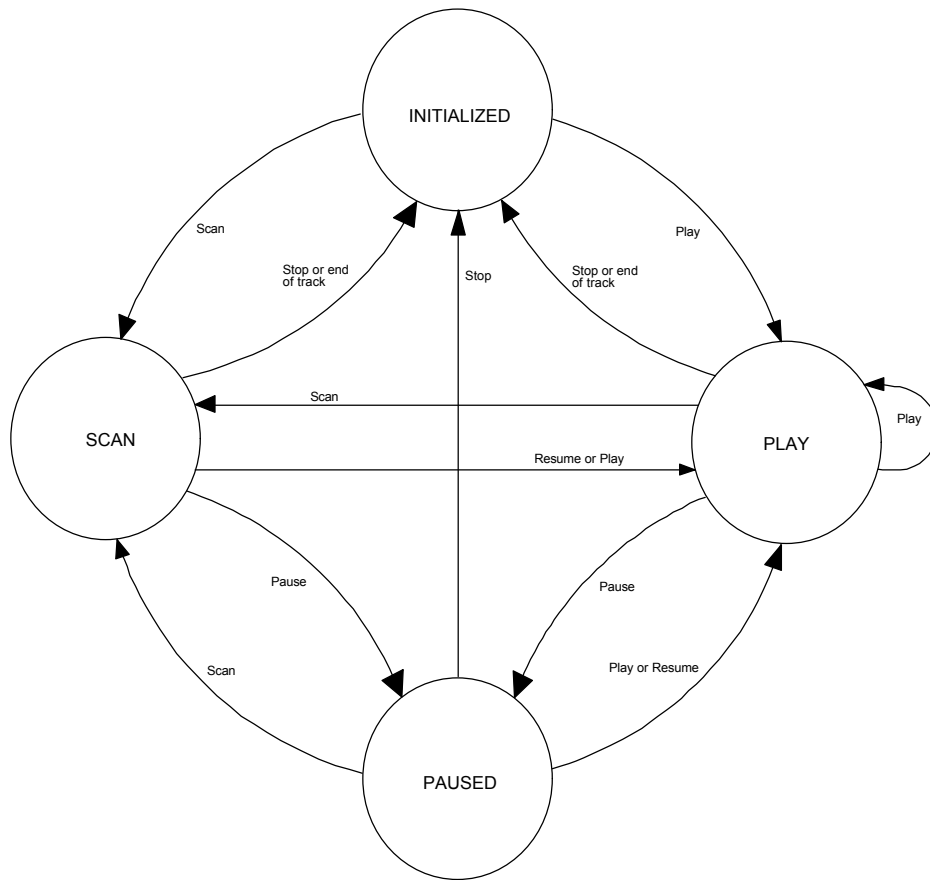

Figure 12 - Stop Play/Play Audio/Audio Scan/Pause/Resume Sequencing

## 5.2. Parameters for CD devices

### 5.2.1. Diagnostic parameters

This sub-clause defines the descriptors and pages for diagnostic parameters used with CD devices.

The diagnostic page codes for CD devices are defined in Table 91.

**Table 91 - Diagnostic page codes**

Page Code	Description	ref. doc.
00h	supported diagnostic pages	SPC
01h - 3Fh	reserved (for all device type pages)	-
40h - 7Fh	reserved	-
80h - FFh	vendor specific pages	-

### 5.2.2. Log parameters

This sub-clause defines the descriptors and pages for log parameters used with CD devices. The log page codes for CD devices are defined in Table 92.

**Table 92 - Log page codes**

Page Code	Description	ref. doc.
00h	Supported log pages	SPC
01h	Buffer over-run/under-run page	SPC
02h	Reserved	SPC
03h	Error counter page (read) page	SPC
04h - 05h	Reserved	SPC
06h	Non medium error page	SPC
07h	Last n error events page	SPC
08h - 2Fh	Reserved	SPC
30h - 3Eh	Vendor specific pages	SPC
3Fh	Reserved	SPC

### 5.2.3. Mode parameters

This sub-clause defines the descriptors and pages for mode parameters used with CD devices.

For more complete information on Mode Parameters see SCSI-3 Primary Commands standard definitions of Mode Parameters. The mode parameter list, including the mode parameter header and mode block descriptor are defined in the SCSI-3 Primary Commands.

The medium-type code field is contained in the mode parameter header. Table 93 defines the medium type values for CD devices.

Table 93 - CD medium type codes

Code	Medium type description
00h	Default (only one type supported)
01h	120 mm CD data only
02h	120 mm CD-DA audio only
03h	120 mm CD data and audio combined (Mixed mode)
04h	Reserved
05h	80 mm CD-ROM data only
06h	80 mm CD-DA audio only
07h	80 mm CD data and audio combined (Mixed mode)
08h - 7Fh	Reserved
80h - FFh	Vendor specific

The device-specific parameter field is contained in the mode parameter header. Table 94 defines the device-specific parameter field for CD devices.

Table 94 - CD device specific parameter

Bit Byte	7	6	5	4	3	2	1	0
1	Reserved			DPOFUA	Reserved			EBC

When used with the MODE SELECT command, the DPOFUA bit is not used and the field is reserved.

When used with the MODE SENSE command, a DPOFUA bit of one indicates that the target supports the DPO and FUA bits (see SCSI Block Commands READ(10) Command description).

The Enable Blank Check (EBC) bit is reserved.

The density code field is contained in the mode parameter block descriptor (see SCSI Primary Commands-Mode Parameters description). Table 95 defines the density code values for CD devices. This field is obsolete and shall be set to 00h.

Table 95 - CD Density codes

code	data types to be transferred
00h	default density code
01h	User data only (2048 bytes per logical sector)
02h	User data plus auxiliary data field (2336 bytes per sector)
03h	4-byte tag field, user data plus auxiliary data (2340 bytes per sector)
04h	Audio information only (1/75th of a second per logical block)
05h - 7Fh	Reserved
80h - FFh	Vendor specific

NOTE: The number of bytes per sector specified by this parameter is used with the block length to map CD sectors to logical block addresses.

The mode page codes for CD devices are defined in Table 96.

**Table 96 - Mode page codes**

Page code	description	ref. doc.
00h	Vendor specific (does not require page format)	-
01h	Read error recovery page	MMC-1
02h	Disconnect re-connect page	SPC
03h-04h	Reserved	-
05h	Write Parameter page	MMC-1
06h	Reserved	-
07h	Verify error recovery page	MMC-1
08h	Caching page	SBC
09h	Peripheral device page	SPC
0Ah	Control mode page	SPC
0Bh	Medium types supported page	SBC
0Ch	Reserved	-
0Dh	CD page	MMC-1
0Eh	CD audio control page	MMC-1
0Fh	Reserved	-
1Ah	Power Condition page	SPC
1Ch	Informational exceptions control page	SPC
1Dh - 1Fh	Reserved	-
20h - 29h	Vendor specific (page format required)	SPC
2Ah	CD Capabilities and Mechanism Status Page	MMC-1
2Bh - 3Eh	Vendor specific (page format required)	SPC
3Fh	Return all pages (valid only for mode sense command)	SPC

## 5.2.3.1. CD Audio Control parameters

The CD audio control parameters page (Table 97) sets the playback modes and output controls for subsequent PLAY AUDIO commands and any current audio playback operation.

Table 97 - CD Audio Control parameters page

Bit Byte	7	6	5	4	3	2	1	0
0	PS	Reserved	Page Code (0Eh)					
1	Page Length (0Eh)							
2	Reserved				IMMED	SOTC	Reserved	
3	Reserved							
4	Reserved							
5	Obsolete							
6	Obsolete							
7	Obsolete							
8	Reserved			Output Port 0 Channel Selection				
9	Output Port 0 Volume							
10	Reserved			Output Port 1 Channel Selection				
11	Output Port 1 Volume							
12	Reserved			Output Port 2 Channel Selection				
13	Output Port 2 Volume							
14	Reserved			Output Port 3 Channel Selection				
15	Output Port 3 Volume							

The parameters savable (PS) bit is only used with the MODE SENSE command. This bit is reserved with the MODE SELECT command. A PS bit of one indicates that the target is capable of saving the page in a non-volatile vendor-specific location.

An immediate (Immed) bit of zero indicates the target shall not send completion status until the audio playback operation is terminated.

An Immed bit of one indicates the target shall send completion status as soon as the playback operation has been started.

NOTE: It is recommended that a Logical Unit reservation be established prior to starting audio play operations with an Immed bit of one in any multiple initiator environment.

A stop on track crossing (SOTC) bit of zero indicates the target shall terminate the audio playback operation when the transfer length is satisfied. Multiple tracks shall be played as necessary. Periods of time encoded as audio pause/silence at the beginning of tracks, (index 0) shall also be played.

A stop on track crossing (SOTC) bit of one indicates the target shall terminate the audio playback operation when the start of a following track is encountered.

The output port channel selection specifies the audio channels from the disc to which this output port should be connected (Table 98). More than one output port may be connected to an audio channel. More than one audio channel may be connected to an output port.



Table 98 - Output port channel selection

code	description
0000b	output port muted
0001b	connect audio channel 0 to this output port
0010b	connect audio channel 1 to this output port
0100b	connect audio channel 2 to this output port
1000b	connect audio channel 3 to this output port

The channel volume control indicates the relative volume level for this audio output port. A value of zero indicates the output is muted, and a value of FFh indicates maximum volume level. The default values for Output Port 0 and Output Port 1 should be set to FFh, and Output Port 2 and Output Port 3 should be set to zero.

## 5.2.3.2. CD device parameters

The CD parameters page (Table 99) specifies parameters that affect all CD-ROM data types.

Table 99 - CD parameters page

Bit Byte	7	6	5	4	3	2	1	0
0	PS	Reserved	Page Code (0Dh)					
1	Parameter Length (06h)							
2	Reserved							
3	Reserved				Inactivity Timer Multiplier			
4	(MSB)	Number Of MSF - S Units Per MSF - M Unit						(LSB)
5								
6	(MSB)	Number Of MSF - F Units Per MSF - S Unit						(LSB)
7								

The parameters savable (PS) bit is only used with the MODE SENSE command. This bit is reserved with the MODE SELECT command. A PS bit of one indicates that the target is capable of saving the page in a non-volatile vendor-specific location.

The inactivity timer value specifies the length of time that the drive shall remain in the hold track state after completion of a seek or read operation (Table 100).

Table 100 - Inactivity timer multiplier values

Inactivity timer value	minimum time in hold track state	Inactivity timer value	Minimum time in hold track state
0	Vendor-specific	8	16 s
1	125 ms	9	32 s
2	250 ms	Ah	1 min.
3	500 ms	Bh	2 min.
4	1 s	Ch	4 min.
5	2 s	Dh	8 min.
6	4 s	Eh	16 min.
7	8 s	Fh	32 min.

The number of S units per M unit field gives the ratio of these MSF address values. For media conforming to the CD data and CD-DA standard, this value is 60.

The number of F units per S unit field gives the ratio of these MSF address values. For media conforming to the CD data and CD-DA standard, this value is 75.

## 5.2.3.3. Read error recovery parameters

The read error recovery parameters page (Table 101) specifies the error recovery parameters the target shall use during any command that performs a data read operation to the media (e.g. READ, READ TOC/PMA/ATIP, etc.).

Table 101 - Read error recovery parameters page

Bit Byte	7	6	5	4	3	2	1	0
0	PS	Reserved	Page Code (01h)					
1	Parameter Length (06h)							
2	Error Recovery Parameter							
3	Read Retry Count							
4	Reserved							
5	Reserved							
6	Reserved							
7	Reserved							

The parameters savable (PS) bit is only used with the MODE SENSE command. This bit is reserved with the MODE SELECT command. A PS bit of one indicates that the target is capable of saving the page in a non-volatile vendor-specific location. The error recovery parameter bits are defined in SCSI Block Commands.

NOTE: The implementation of error recovery procedures for CD devices is markedly different from those used for magnetic medium disk drives. At least one level of error correction (i.e. CIRC) is required to transfer the data stream. Therefore, the performance of the drive may differ substantially from what would be expected by sending the same error recovery parameters to a magnetic medium device.

The correlation of the error recovery parameter and the bit settings defined for CD devices is given in Table 102. The interpretation of these codes for CD devices is given in Table 107. If the error recovery parameter is set to any other value, the command shall be terminated with CHECK CONDITION status. The sense key shall be set to ILLEGAL REQUEST and the additional sense code set to INVALID FIELD IN PARAMETER LIST.

Table 102 - Error Recovery Parameter Bit Settings

Error Recovery Parameter	Bit Settings 7 6 5 4 3 2 1 0	Error Recovery Parameter	Bit Settings 7 6 5 4 3 2 1 0
00h	R R 0 0 R 0 0 0	20h	R R 1 0 R 0 0 0
01h	R R 0 0 R 0 0 1	21h	R R 1 0 R 0 0 1
04h	R R 0 0 R 1 0 0	24h	R R 1 0 R 1 0 0
05h	R R 0 0 R 1 0 1	25h	R R 1 0 R 1 0 1
06h	R R 0 0 R 1 1 0	26h	R R 1 0 R 1 1 0
07h	R R 0 0 R 1 1 1	27h	R R 1 0 R 1 1 1
10h	R R 0 1 R 0 0 0	30h	R R 1 1 R 0 0 0
11h	R R 0 1 R 0 0 1	31h	R R 1 1 R 0 0 1
14h	R R 0 1 R 1 0 0	34h	R R 1 1 R 1 0 0
15h	R R 0 1 R 1 0 1	35h	R R 1 1 R 1 0 1

R = Reserved and shall be set to zero

## 5.2.3.4. CD Capabilities and Mechanical Status Page

This page is read only and may not be set by the Mode Select command. The format and content of the page is defined in Table 103 below.

Table 103 - CD Capabilities and Mechanical Status Page

Bit Byte	7	6	5	4	3	2	1	0
0	PS	Reserved	Page Code (2Ah)					
1	Page Length (14h)							
2	Reserved					Method 2	CD-RW Read	CD-R Read
3	Reserved					Test Write	CD-RW Write	CD-R Write
4	Reserved	Multi Session	Mode 2 Form 2	Mode 2 Form 1	Digital Port (2)	Digital Port (1)	Composite	Audio Play
5	Read Bar Code	UPC	ISRC	C2 Pointers are supported	R-W De-interleaved & corrected	R-W Supported	CD-DA Stream is Accurate	CD-DA Commands Supported
6	Loading Mechanism Type			Reserved	Eject (Individual or Cartridge)	Prevent Jumper	Lock State	Lock
7	Reserved				S/W Slot Selection (SSS)	Changer Supports Disc Present reporting	Separate Channel Mute Supported	Separate volume levels per channel
8	(MSB) Maximum Read Speed Supported (in kbps)							
9	(LSB)							
10	(MSB) Number of Volume Levels Supported							
11	(LSB)							
12	(MSB) Buffer Size supported by Drive (in KBytes)							
13	(LSB)							
14	(MSB) Current Read Speed Selected (in kbps)							
15	(LSB)							
16	Reserved							
17	Reserved	Length			LSBF	RCK	BCK	Reserved
18	(MSB) Maximum Write Speed Supported (in kbps)							
19	(LSB)							
20	(MSB) Current Write Speed Selected (in kbps)							
21	(LSB)							

The individual capabilities of the drive are specified by bytes 2 through 7. Each of the bits indicate that the specific capability is supported. A value of zero indicates that the capability is not supported; a value of one indicates the capability is supported.

Byte 2, Bit 0, CD-R Read, indicates the device supports reading of CD-R discs, including incomplete areas.

Byte 2, Bit 1, CD-RW Read, indicates the device supports reading of CD-RW discs.

Byte 2, Bit 2, Method 2, indicates the device supports the read function of CD media written with fixed packet tracks using Addressing Method 2.

Byte 3, Bit 0, CD-R Write, indicates the device supports writing CD-R discs.

Byte 3, Bit 1, CD-RW Write, when set to one, indicates the device supports writing CD-RW discs.

Byte 3, Bit 2, Test Write, when set to one, indicates the device supports the test write function. See Write Parameters Mode Page (sub-clause 6.1.1.).

Byte 4, Bit 0, Audio Play, indicates the drive is capable of Audio Play operation. This also indicates that the drive is capable of overlapping Play and other commands such as reading of Sub-channel information.

Byte 4, Bit 1, Composite, indicates the drive is capable of delivering a composite Audio and Video data stream.

Byte 4, Bit 2, Digital Port (1), indicates the drive supports digital output (IEC 958) on port 1.

Byte 4, Bit 3, Digital Port (2), indicates the drive supports digital output (IEC 958) on port 2.

Byte 4, Bit 4, Mode 2 Form 1, indicates the drive is capable of reading sectors in Mode 2 Form 1 (XA) format.

Byte 4, Bit 5, Mode 2 Form 2, indicates the drive is capable of reading sectors in Mode 2 Form 2 format.

Byte 4, Bit 6, Multi Session, indicates the drive is capable of reading multi-session discs.

Byte 5, Bit 0, CD-DA Commands Supported, audio can be read using the READ CD command.

Byte 5, Bit 1, CD-DA Stream is Accurate, indicates that the drive supports an advanced feature that allows it to return to an audio location without losing place to continue the READ CD command.

Bit 1 = 0 The drive is incapable of accurately restarting the CD-DA read operation, and a BUFFER OVERFLOW error shall be reported whenever a loss of streaming occurs. This error will be fatal and the command will have to be repeated from the beginning.

Bit 1 = 1 The drive can continue from a loss of streaming condition and no error will be generated.

Byte 5, Bit 2, R-W Supported, indicates the commands that return Sub-channel data can return the combined R-W information.

Byte 5, Bit 3, R-W De-interleaved & Corrected, indicates that the R-W sub-channel data will be returned de-interleaved and error corrected.

Byte 5, Bit 4, C2 Pointers are Supported, indicates that the drive supports the C2 Error Pointers. This also indicates that the drive is capable of returning the C2 Error Pointers and C2 Block Error bits in the READ CD command.

Byte 5, Bit 5, ISRC, indicates the drive can return the International Standard Recording Code Information.

Byte 5, Bit 6, UPC, the drive can return the Media Catalog Number (UPC)

Byte 5, Bit 7, Read Bar Code, indicates the device supports reading disc bar codes.

Byte 6, Bit 0, LOCK, indicates the PREVENT/ALLOW command is capable of actually locking the media into the drive.

Byte 6, Bit 1, Lock State, indicates the current state of the drive.

Bit 1 = 0 The drive is currently in the allow (Unlocked) state. Media may be inserted or ejected.

Bit 1 = 1 The drive is currently in the prevent (Locked) state. Media loaded in the drive may not be removed via soft or hard eject. If the drive is empty, media may not be inserted if the Prevent Jumper is not present. If the jumper is present, then media may be inserted.

Byte 6, Bit 2, Prevent Jumper, indicates the state of the (Optional) Prevent/Allow Jumper.

Bit 2 = 0 Jumper is present. Drive will power up to the allow state. Locking the drive with the Prevent/Allow command shall NOT prevent the insertion of media.

Bit 2 = 1 Jumper is not present. Drive will power up to the Prevent State (Locked). The drive will not accept new media or allow the ejection of media already loaded until an allow command is issued.

Byte 6, Bit 3, Eject Command, the drive can eject the disc via the normal START/STOP command with the LoEj bit set. If the mechanism is a Changer that uses a cartridge, then this bit indicates that the cartridge can be ejected.

Byte 6, Bit 5-7, Loading Mechanism Type, field specifies the type of disc loading the drive supports. Table 104 defines the field values.

Table 104 - Loading Mechanism Type

Bit 7	Bit 6	Bit 5	Definition
0	0	0	Caddy type loading mechanism
0	0	1	Tray type loading mechanism
0	1	0	Pop-up type loading mechanism
0	1	1	Reserved
1	0	0	Changer with individually changeable discs
1	0	1	Changer with cartridge Mechanism
1	1	0	Reserved
1	1	1	Reserved

Byte 7, Bit 0, Separate Volume Levels, indicates the audio level for each channel can be controlled independently.

Byte 7, Bit 1, Separate Channel Mute, indicates the mute capability for each channel can be controlled independently.

Byte 7, Bit 2, Individual Disc Present, indicates that the Device contains an embedded changer, and that after a reset condition or if a cartridge is change, it can report the exact contents of the slots. The response to the MECHANISM STATUS command will contain valid Disc is Present status information for all slots.

Byte 7, Bit 3, Software Slot Selection (SSS), controls the behavior of the LOAD/UNLOAD command when trying to load a Slot with no Disc present. See Table 13.

The Maximum Read Speed Supported field indicates the actual maximum data rate that the drive supports. This value is returned as the number of kilobytes per/second (Speed/1000) that the data is read from the drive. Table 105 identifies the data rates.

Table 105 - Data Rate Examples

Speed	Data Rate
1X	176 KBytes/second
2X	353 KBytes/second
2.2X	387 KBytes/second
3X	528 KBytes/second
4X	706 KBytes/second
8X	1.4 MBytes/second
16X	2.8 MBytes/second

Note that these are the raw data rates and do not reflect any overhead resulting from headers, error correction data, etc. that the reported data rate is a theoretical maximum and the actual data rates to the initiator may be lower.

The Number of Volume Levels Supported field returns the number of discrete levels. If the drive only supports turning audio on and off, the Number of Volume Levels shall be set to 2.

The Buffer Size Supported field returns the number of bytes of buffer dedicated to the data stream returned to the initiator. This value is returned in KBytes (Size/1024). If the drive does not have a buffer cache, the value returned shall be zero.

The Current Read Speed Selected field indicates the actual data rate that the drive is currently using. This value is returned as the number of kilobytes per/second (Speed/1000) that the data is read from the drive.

Byte 17 is used to describe the format of the drive's digital output.

Bit 1 BCKF Set if data valid on the falling edge of the BCK signal. Clear if data valid on rising edge of the BCK signal.

Bit 2 RCK Set if HIGH on LRCK indicates left channel. Clear if HIGH on LRCK indicates right channel.

Bit 3 LSBF Set if LSB first. Clear if MSB first.

Bit 4 -5 Length  
 00b = 32 BCKs  
 01b = 16 BCKs  
 10b = 24 BCKs  
 11b = 24 BCKs (I<sup>2</sup>S)

The Maximum Write Speed Supported field indicates the actual maximum data rate that the drive supports independent of media type. This value is returned as the number of kilobytes per/second (Speed/1000) that the data may be written to the drive. Table 105 identifies the data rates.

The Current Write Speed Selected field indicates the actual data rate that the device is currently using. This value is returned as the number of kilobytes per/second (Speed/1000) that the data is read from the drive.

## 5.2.3.5. Verify error recovery parameters

The verify error recovery parameters page (Table 106) specifies the error recovery parameter the target shall use during verify operations.

Table 106 - Verify error recovery parameters page

Bit Byte	7	6	5	4	3	2	1	0
0	PS	Reserved	Page Code (07h)					
1	Parameter Length (06h)							
2	Error Recovery Parameter							
3	Verify Retry Count							
4	Reserved							
5	Reserved							
6	Reserved							
7	Reserved							

The page savable (PS) bit is only used with the MODE SENSE command. This bit is reserved with the MODE SELECT command. A PS bit of one indicates that the target is capable of saving the page in a non-volatile vendor-specific location. The error recovery parameters for verify operations are as defined by the read error recovery parameters (see Table 101 - Read error recovery parameters page).



Table 107 - CD Devices, error recovery description

error code	description
00h	<p>The maximum error recovery procedures available are used. If an error occurs which is uncorrectable with the error correction codes (ECC) on the media, data transfer is terminated with CHECK CONDITION status. The block with the error is not transferred. The sense key is set to MEDIUM ERROR. The information bytes give the address of the block where the un-recovered error was detected. Recovered errors are not reported.</p>
01h	<p>Only retries of the read operation and CIRC are used (layered error correction is not used). Only CIRC un-recovered data errors are reported. If an CIRC un-recovered data error occurs, data transfer is terminated with CHECK CONDITION status. The block with the error is not transferred. The sense key is set to MEDIUM ERROR. The information bytes give the address of the block where the un-recovered error was detected. Recovered errors are not reported.</p>
04h	<p>The maximum error recovery procedures available are used. Recovered data errors are reported. If a recovered data error occurs, data transfer is not terminated. However, when the data transfer has completed CHECK CONDITION status is reported. The sense key is set to RECOVERED ERROR. The information bytes give the address of the last block where a recovered data error was detected.</p> <p>If a data error occurs that is uncorrectable with the ECC information available on the media, data transfer is terminated and CHECK CONDITION status is reported. The block with the error is not transferred. The sense key is set to MEDIUM ERROR. The information bytes give the address of the block where the uncorrectable error was detected.</p>
05h	<p>Only retries of the read operation and CIRC are used (layered error correction is not used). Recovered data errors are reported. If a recovered data error occurs, data transfer is not terminated. However, when the data transfer has completed CHECK CONDITION status is reported. The sense key is set to RECOVERED ERROR. The information bytes give the address of the last block where a CIRC recovered data error was detected.</p> <p>If an un-recovered data error occurs, data transfer is terminated and CHECK CONDITION status is reported. The block with the error is not transferred. The sense key is set to MEDIUM ERROR. The information bytes give the address of the block where the un-recovered error was detected.</p>
06h	<p>The maximum error recovery procedures are used. Recovered data errors are reported. If a recovered data error occurs data transfer is terminated and CHECK CONDITION status is reported. The block with the recovered error is not transferred. The sense key is set to RECOVERED ERROR. The information bytes give the address of the block where the recovered data error was detected.</p> <p>If a data error occurs that is uncorrectable with the ECC information on the medium, data transfer is terminated with CHECK CONDITION status. The block with the error is not transferred. The sense key is set to MEDIUM ERROR. The information bytes give the address of the block where the uncorrectable error was detected.</p>

Table 107 (cont.) - CD Devices, error recovery description

error code	description
07h	<p>Only retries of the read operation are used (layered error correction is not used). CIRC recovered data errors are reported. If a CIRC recovered data error occurs, data transfer is terminated with CHECK CONDITION status. The block with the recovered error is not transferred. The sense key is set to RECOVERED ERROR. The information bytes give the address of the block where the recovered data error was detected.</p> <p>If an CIRC un-recovered data error occurs, data transfer is terminated with CHECK CONDITION status. The block with the error is not transferred. The sense key is set to MEDIUM ERROR. The information bytes give the address of the block where the uncorrectable error was detected.</p>
10h	<p>If data transfer can be maintained, the maximum error recovery procedures available are used. (RC=1.) If an error occurs which is uncorrectable with the error codes (ECC) on the media, or is uncorrectable in time to maintain data transfer, the data transfer is not terminated. However, when the data transfer has completed, CHECK CONDITION status is reported. The sense key is set to MEDIUM ERROR. The information bytes give the address of the block where the first un-recovered error was detected. Recovered errors are not reported.</p>
11h	<p>If data transfer can be maintained, retries of the read operation and CIRC are used (layered error correction is not used). (RC=1.) Only CIRC un-recovered data errors are reported. If a CIRC un-recovered data error occurs, data transfer is not terminated. However, when data transfer has completed, CHECK CONDITION status is reported. The sense key is set to MEDIUM ERROR. The information bytes give the address of the block where the first un-recovered error was detected. Recovered errors are not reported.</p> <p>If a data error occurs that is uncorrectable with the ECC information available on the media, data transfer is terminated and CHECK CONDITION status is reported. The block with the error is not transferred. The sense key is set to MEDIUM ERROR. The information bytes give the address of the block where the uncorrectable error was detected.</p>
14h	<p>If data transfer can be maintained, the maximum error recovery procedures available are used. (RC=1.) Recovered data errors are reported. If a recovered data error occurs, data transfer is not terminated. However, when the data transfer has completed, CHECK CONDITION status is reported. The sense key is set to RECOVERED ERROR. The information bytes give the address of the block where a recovered data error was detected.</p> <p>If an data error occurs that is uncorrectable with the ECC information available on the media, or is uncorrectable in time to maintain data transfer, the data is not terminated. However, when the data transfer has completed, CHECK CONDITION status is reported. The sense key is set to MEDIUM ERROR. The information bytes give the address of the block where the first un-recovered error was detected. Reporting un-recovered errors takes precedence over reporting recovered errors.</p>
15h	<p>If data transfer can be maintained, retries of the read operation and CIRC are used (layered error correction is not used). (RC=1.) Recovered data errors are reported. If a recovered data error occurs, data transfer is not terminated. However, when the data transfer has completed CHECK CONDITION status is reported. The sense key is set to RECOVERED ERROR. The information bytes give the address of the block where a CIRC recovered data error was detected.</p> <p>If an un-recovered data error occurs, data transfer is not terminated. However, when the data transfer has completed CHECK CONDITION status is reported. The sense key is set to MEDIUM ERROR. The information bytes give the address of the block where the un-recovered error was detected. Recovered errors are not reported.</p>

Table 107 (cont.) - CD Devices, error recovery description

error code	description
20h	<p>The maximum error recovery procedures available are used. If an error occurs which is uncorrectable with the error correction codes (ECC) on the media, data transfer is terminated with CHECK CONDITION status. The block with the error is transferred. The sense key is set to MEDIUM ERROR. The information bytes give the address of the block where the un-recovered error was detected. Recovered errors are not reported.</p>
21h	<p>Only retries of the read operation and CIRC are used (layered error correction is not used). Only CIRC un-recovered data errors are reported. If an CIRC un-recovered data error occurs, data transfer is terminated with CHECK CONDITION status. The block with the error is transferred. The sense key is set to MEDIUM ERROR. The information bytes give the address of the block where the un-recovered error was detected. Recovered errors are not reported.</p>
24h	<p>The maximum error recovery procedures available are used. Recovered data errors are reported. If a recovered data error occurs, data transfer is not terminated. However, when the data transfer has completed, CHECK CONDITION status is reported. The sense key is set to RECOVERED ERROR. The information bytes give the address of the last block where a recovered data error was detected.</p> <p>If a data error occurs that is uncorrectable with the ECC information available on the media, data transfer is terminated and CHECK CONDITION status is reported. The block with the error is transferred. The sense key is set to MEDIUM ERROR. The information bytes give the address of the block where the uncorrectable error was detected.</p>
25h	<p>Only retries of the read operation and CIRC are used (layered error correction is not used). Recovered data errors are reported. If a recovered data error occurs, data transfer is not terminated. However, when the data transfer has completed CHECK CONDITION status is reported. The sense key is set to RECOVERED ERROR. The information bytes give the address of the last block where a CIRC recovered data error was detected.</p> <p>If an un-recovered data error occurs, data transfer is terminated and CHECK CONDITION status is reported. The block with the error is transferred. The sense key is set to MEDIUM ERROR. The information bytes give the address of the block where the un-recovered error was detected.</p>
26h	<p>The maximum error recovery procedures are used. Recovered data errors are reported. If a recovered data error occurs data transfer is terminated and CHECK CONDITION status is reported. The block with the recovered error is transferred. The sense key is set to RECOVERED ERROR. The information bytes give the address of the block where the recovered data error was detected.</p> <p>If a data error occurs that is uncorrectable with the ECC information on the medium, data transfer is terminated with CHECK CONDITION status. The block with the error is transferred. The sense key is set to MEDIUM ERROR. The information bytes give the address of the block where the uncorrectable error was detected.</p>

Table 107 (cont.) - CD Devices, error recovery description

error code	description
27h	<p>Only retries of the read operation are used (layer error correction is not used). CIRC recovered data errors are reported. If a CIRC recovered data error occurs, data transfer is terminated with CHECK CONDITION status. The block with the recovered error is transferred. The sense key is set to RECOVERED ERROR. The information bytes give the address of the block where the recovered data error was detected.</p> <p>If a CIRC un-recovered data error occurs, data transfer is terminated with CHECK CONDITION status. The block with the error is transferred. The sense key is set to MEDIUM ERROR. The information bytes give the address of the block where the un-recovered error was detected.</p>
30h	Same as code 10h
31h	Same as code 11h
34h	Same as code 14h
35h	Same as code 15h

## 6. CD-RECORDABLE/REWRITABLE (CD-R/RW)

The writing of a CD-R/RW disc requires the Initiator read a set of parameters from the device, selecting the parameters to be used, setting those parameters in the write parameters of the device and then using the normal SCSI-3 Write Command. Once the write process has begun, data is streamed from the initiator to the target device.

### 6.1. Write Parameters

This sub-clause contains information common to all write commands.

#### 6.1.1. Write Parameters Mode Page

The Write Parameters Mode Page (see Table 108) contains parameters needed for the correct execution of write commands.

The values in this page do not necessarily reflect the status on a given track. They will be used as applicable when a write operation occurs. If any parameters have values incompatible with the current track, a check condition status shall occur when a write is attempted.

The PS bit (parameters savable) (see Table 108) is only used with the MODE SENSE command. This bit is reserved with the MODE SELECT command. A PS bit of one indicates that the target is capable of saving the page in a non-volatile, vendor-specific location. If the PS bit is set to one in MODE SENSE data, then the page shall be savable by issuing a MODE SELECT command with SP set to one.

Table 108 - Write Parameters Mode Page

Bit Byte	7	6	5	4	3	2	1	0
0	PS	Reserved	Page Code (05h)					
1	Page Length (32h)							
2	Reserved			Test Write	Write Type			
3	Multi-session		FP	Copy	Track Mode			
4	Reserved				Data Block Type			
5	Reserved							
6	Reserved							
7	Reserved		Host Application Code					
8	Session Format							
9	Reserved							
10	(MSB) Packet Size (LSB)							
11								
12								
13								
14	(MSB) Audio Pause Length (LSB)							
15								
16	(MSB) Media Catalog Number (LSB)							
17								
...								
30								
31								
32								
33	(MSB) International Standard Recording Code (LSB)							
...								
46								
47								
48	Sub-header Byte 0							
49	Sub-header Byte 1							
50	Sub-header Byte 2							
51	Sub-header Byte 3							
52	Vendor Specific							
53	Vendor Specific							
54	Vendor Specific							
55	Vendor Specific							

The Test Write bit (see Table 108) is valid only for Write Type 1 or 2 (Track at Once or Session at Once). When the Test Write bit is set to one, it indicates that the device performs the write process, but does not write data to the media. When the bit is set to zero the Write laser power is set such that user data is transferred to the CD media. In addition, all track and disc information collected, during test write mode, shall be cleared. It should be noted that the number of tracks reserved or written may be limited in test write mode.

Write Type (Table 109) specifies the CD-R/RW stream type to be used during writing. Write Type values are shown in Table 109.

**Table 109 - Write Type Field**

Value	Definition
00h	Packet
01h	Track-at-once
02h	Session-at-once
03h	Raw
04h - 0Fh	Reserved

Packet - the device shall perform packet writing when write commands are issued.

Track at Once - the device shall perform track at once recording when write commands are issued.

Session at Once - the device shall perform session at once recording. This mode requires that a cue sheet be sent prior to sending write commands.

Raw - the device shall write data as received from the initiator. In this mode, the initiator sends the lead-in. As the initiator must provide Q sub-channel in this mode, the only valid Data Block Types are 1, 2, and 3. The Next Writable Address starts at the beginning of the lead-in (which shall be a negative LBA on a blank disc).

NOTE: In RAW record mode the drive shall not generate run-in and run-out blocks (main and sub-channel 1 data) but shall generate and record the link block.

The Multi-session field defines how session closure affects the opening of the next session. See Table 110.

**Table 110 - Multi-session Field Definition**

Multisession Field	Action Upon Session Closure
00b	No B0 pointer. Next Session not allowed
01b	B0 pointer = FF:FF:FF. Next session not allowed
10b	Reserved
11b	Next session allowed. B0 pointer = next possible program area.

The FP bit, when set to one indicates that the packet type is fixed. Otherwise, the packet type is variable. This bit is ignored unless the write type is set to 0 (Packet).

Track Mode is the Control nibble in all mode 1 Q sub-channel in the track.

A Copy bit with value one indicates that this is the first or higher generation copy of a copyright protected track. When set to one, the copyright bit in the control nibble of each mode 1 Q sub-channel shall alternate between 1 and 0 at 9.375 Hz. The duty cycle is 50%, changing every 4 blocks. The initial value on the medium is zero.

Data Block Type defines both the specific data fields in a user data block and its size. The Data Block Type is as defined in Table 111. This size is used for writing instead of the block size set in the mode select header.

Table 111 - Data Block Type Codes

Value	Block Size	Definition	Requirement
0	2352	Raw data 2352 bytes of raw data (not valid for write type = packet)	Optional
1	2368	Raw data with P and Q sub-channel 2352 bytes of raw data, 16 bytes buffer for Q sub-channel: Bytes 0..9 are Q sub-channel data Bytes 10..11 are Q sub-channel EDC Bytes 12..14 are zero Byte 15, most significant bit has state of P sub-channel bit (not valid for write type = packet)	Optional
2	2448	Raw data with P-W sub-channel appended: 2352 bytes of raw data. 96 bytes of pack form R-W sub-channel in the low order 6 bits of each byte. Bit 7 of each byte contains the P sub-channel state and bit 6 of each byte contains the Q sub-channel bit. (not valid for write type = packet)	Optional
3	2448	Raw data with raw P-W sub-channel appended: 2352 bytes of raw data. 96 bytes of raw P-W sub-channel. (not valid for write type=packet)	Optional
4 - 6		Reserved values	-
7	NA	Vendor Specific	Optional
8	2048	Mode 1 (ISO/IEC 10149): 2048 bytes of user data	Mandatory
9	2336	Mode 2 (ISO/IEC 10149): 2336 bytes of user data	Optional
10	2048	Mode 2 (CD-ROM XA, form 1): 2048 bytes of user data, sub-header from write parameters	Mandatory
11	2056	Mode 2 (CD-ROM XA, form 1): 8 bytes of sub-header, 2048 bytes of user data	Optional
12	2324	Mode 2 (CD-ROM XA, form 2): 2324 bytes of user data, sub-header from write parameters	Optional
13	2332	Mode 2 (CD-ROM XA, form 1, form 2, or mixed form): 8 bytes of sub-header 2324 bytes of user data	Mandatory
14	-	Reserved	-
15	NA	Vendor Specific	Optional

## NOTES:

1. When a track has been designated for packet writing, the device shall ensure that the TDB is written upon receipt of the write command.
2. With the exceptions of data block types 1, 2, and 3, the device shall generate all P sub-channel and all mode 1, mode 2, and mode 3 Q sub-channel.
3. For data block types 8 through 13, the device shall generate all sync fields and all headers.
4. For data blocks of mode 1 or of mode 2, form 1, the device shall generate EDC and L-EC parity.
5. For data block types 0, 1, 2, and 3, the device shall perform no data scrambling per ISO/IEC 10149.
6. For data block types 8 through 13, the device shall perform data scrambling per ISO/IEC 10149.



The Host Application Code is typically zero. When the unrestricted Use Disc bit in Disc Information Block (see Table 130) is one, the Host Application Code shall be ignored by the device. If the Unrestricted Use Disc bit is zero, then the Host Application Code shall be set to the appropriate value for the medium in order that writing be allowed. A Host Application Code of zero is used for a Restricted Use - General Purpose Disc.

The Session Format code is to be written in the TOC of the session containing this track. The Session Format code is the PSEC byte of the mode 1, point A0 TOC entry. See Table 112

**Table 112 - Session Format Codes**

Disc Type Code	Session Format
00h	CD-DA or CD-ROM Disc
10h	CD-I Disc
20h	CD-ROM XA Disc
All Other Values	Reserved

The Packet Size field specifies the number of User Data Blocks per fixed packet.

Audio Pause Length is the number of blocks from the beginning of the track for which the mode 1 Q sub-channel INDEX shall be zero. If this number is zero, then there is no period where the Mode 1 Q sub-channel INDEX shall be zero. The default value shall be 150. This field is valid only for audio tracks, otherwise it is ignored.

The Media Catalog Number (MCN) is formatted as in Table 63. The MCN will be written in a mode 2 Q sub-channel in at least one out of every 100 blocks in the program area.

The International Standard Recording Code (ISRC) is formatted as in Table 65.

## 6.2. CD-R/RW Commands

The definitions describe in the following sub-clauses are unique to the recording of information on a CD disc.

### 6.2.1. CD-R/RW Command Listing

Table 113 lists the commands that are specific to CD-R/RW devices. The commands identified as mandatory in Table 113 shall be implemented in MMC compliant devices. In addition, commands identified as mandatory in Table 11 shall be implemented.

**Table 113 - Commands Specific to CD-R/RW Devices**

Command Name	Operation Code	Type	sub-clause
BLANK Command	A1h	E	6.2.2.
CLOSE TRACK/SESSION	5Bh	M	6.2.3.
FORMAT UNIT	04h	O	6.2.4.
READ BUFFER CAPACITY	5Ch	O	6.2.5.
READ DISC INFORMATION	51h	M	6.2.6.
READ MASTER CUE	59h	O	6.2.7.
READ TRACK INFORMATION	52h	M	6.2.8.
REPAIR TRACK	58h	O	6.2.9.
RESERVE TRACK	53h	M	6.2.10.
SEND CUE SHEET	5Dh	O	6.2.11.
SEND OPC INFORMATION	54h	O	6.2.12.
SYNCHRONIZE CACHE	35h	M	6.2.13.
WRITE (10)	2Ah	M	6.2.14.

Type: M = command implementation is mandatory  
 O = command implementation is optional  
 E = mandatory for CD-RW devices

## 6.2.2. BLANK Command

CD-RW discs have two properties not available with CD-R: direct-overwrite and erasability. The BLANK command provides the ability to erase any part of a CD-RW disc.

Table 114 - BLANK Command Descriptor Block

Bit Byte	7	6	5	4	3	2	1	0
0	Operation Code (A1h)							
1	Reserved			Reserved		Blanking Type		
2	(MSB) Start Address/Track Number (LSB)							
3								
4								
5								
6	Reserved							
7	Reserved							
8	Reserved							
9	Reserved							
10	Reserved							
11	Control Byte							

Note: The erasing action performed in this command is a Logical Erase.

Blanking Type identifies the method and coverage of blanking. The codes for Blanking Type are defined in Table 115.

Start Address/Track Number is the LBA at which a range for erasure begins:

- a) When Blanking Type is Blank a Track Tail, this field indicates the start LBA.
- b) When Blanking Type is Blank a Track, this field indicates the track.

Table 115 - Blanking Types

Code	Type	Name	Description
000b	Mandatory	Blank the disc	The entire disc is to be erased. The Start Address parameter is ignored. This is used for clearing a complete disc. After completion of this command the disc is blank.
001b	Mandatory	Minimally blank the disc	Erases only the PMA, first session TOC and the pre-gap of the first track. The Start Address parameter is ignored. This is used for blanking a disc quickly. After completion of this command the disc is treated as a blank disc. Caution must be exercised when using this command as the program area still contains user data.
010b	Optional	Blank a Track	Erases the track specified in the Start Address/Track Number field. This command erases the track only, it does not erase the TOC or the PMA. The track to be erased shall be in the incomplete session.
011b	Optional	Unreserve a Track	This is valid only when the last recorded track is incomplete, reserved, or is complete and in an incomplete session. If the last track is incomplete the track and PMA entry for incomplete track is erased. If the track is reserved or complete, the track and PMA entry of the track is erased. The Start Address/Track Number parameter is ignored.
100b	Mandatory	Blank a Track Tail	Erase the area between the LBA specified Start Address/Track Number field and the end of the track which includes the LBA specified. The LBA specified shall be the first user data block within a packet. This blank type is valid for only a Packet track. This may be used to prepare for writing a packet track to a CD-RW disc with the same write process as a CD-R. The track to be erased shall be in an incomplete session.
101b	Optional	Unclose the last session	Erases the lead-in and lead-out of the last session. The last session shall be complete when this command is issued.
110b	Optional	Erase Session	If the last session is complete, its lead-in, program area, and lead-out shall be erased. If the last session is incomplete, its program area shall be erased. If the last session is empty, the complete session immediately preceding the empty session shall be erased. If the empty session is the only session on the disc, erasing shall not be considered an error.
111b		Reserved	

Table 116 - Recommended errors for BLANK Command

Error	Reference
Deferred Errors	Sub-clause A.1
General Errors	Table A.2
Media Access Errors	Table A.3
Write Errors	Table A.4
ERASE FAILURE	Table A.1

## 6.2.3. CLOSE TRACK/SESSION Command

The CLOSE TRACK/SESSION Command allows closure of either a track or a session.

**Table 117 - CLOSE TRACK/SESSION Command Descriptor Block**

bit byte	7	6	5	4	3	2	1	0
0	Operation Code (5Bh)							
1	Reserved							Immed
2	Reserved						Session	Track
3	Reserved							
4	Reserved							
5	Track Number							
6	Reserved							
7	Reserved							
8	Reserved							
9	Control Byte							

The Immed bit allows execution of the close function as an immediate operation. If Immed is zero, then the requested close operation is executed to completion prior to returning status. If Immed is one, then status is returned once the close operation has begun.

The Session and Track bits (see Table 118) have the following meanings:

**Table 118 - Session and Track Bits Definitions**

Session	Track	Close Actions
0	0	Reserved, not valid
0	1	Close the track associated with the track number in the CDB. If this is the incomplete track, Pad only to the minimum length of 4 seconds. No other padding is to be done. If this is the partially recorded or empty reserved track, the device shall pad the track. In the case of an empty track, the device shall write the track according to the write parameter page. If the write parameter page is inconsistent with the PMA, CHECK CONDITION shall be set to ILLEGAL MODE FOR THIS TRACK.
1	0	Close session. If all tracks in the last session are not complete, generate Check Condition Status.
1	1	Reserved, not valid

If a session or track is to be closed that is already closed, no error shall be reported.

If Session is set to zero and Track is set to one, byte 5 of the CDB contains the track number of the track to close. If the track number is FFh, then the incomplete track is to be closed. Byte 5 of the CDB shall be ignored if the session bit is set.

In order to close the incomplete track, the following steps are required:

- 1) If necessary, the track is padded to the minimum length of 4 seconds.
- 2) The PMA is consulted in order to locate the largest track number recorded, N.
- 3) The bounds of the track are determined and a PMA entry is written for track N+1.

Closing a session shall cause the lead-in and lead-out to be written for the incomplete session. Closing a session when the last session is closed shall not be considered an error. Closing a session when the last session is empty shall result in a CHECK CONDITION status and sense data set to 05/71/04.

If partially recorded, empty, or incomplete tracks exist in the incomplete session, the drive shall issue CHECK CONDITION status, sense data set to 05/71/04.

**Table 119 - Recommended errors for CLOSE TRACK/SESSION Command**

Error	Reference
Deferred Errors	Sub-clause A.1
General Errors	Table A.2
Media Access Errors	Table A.3
Write Errors	Table A.4
SESSION FIXATION ERROR	Table A.1
SESSION FIXATION ERROR WRITING LEAD-IN	Table A.1
SESSION FIXATION ERROR WRITING LEAD-OUT	Table A.1
SESSION FIXATION ERROR - INCOMPLETE TRACK IN SESSION	Table A.1
EMPTY OR PARTIALLY WRITTEN RESERVED TRACK	Table A.1

## 6.2.4. FORMAT UNIT command

The FORMAT UNIT Command (Table 120) formats CD-RW medium into initiator addressable logical blocks per the initiator defined options.

Table 120 - Format Unit Command

Bit Byte	7	6	5	4	3	2	1	0	
0	Operation Code (04h)								
1	Reserved			Fmt	Cmp	Format Code			
2	Reserved								
3	(MSB)	Interleave Value							
4								(LSB)	
5	Control Byte								

A formatted CD-RW session shall consist of a single, fixed packet track. The packet size specified in the WRITE PARAMETERS mode page defines packet size for the format operation. If the WRITE TYPE field in the WRITE PARAMETERS mode page is not packet (00b), the FORMAT UNIT command shall terminate with a CHECK CONDITION and set sense to ILLEGAL REQUEST, COMMAND SEQUENCE ERROR. If the FP bit in the WRITE PARAMETERS mode page is not set to one (Fixed Packet), the FORMAT UNIT command shall terminate with a CHECK CONDITION and set sense to ILLEGAL REQUEST, COMMAND SEQUENCE ERROR.

A FmtData bit of zero indicates that there is no parameter list. A FmtData bit of one indicates that a parameter list is available. For CD-RW, FmtData shall be set to one.

A CmpList bit of zero indicates that the parameter list provided is in addition to those already available to the device. A CmpList bit of one indicates that the parameter list is complete and the device is to ignore any existing parameters. For CD-RW, CmpList shall be cleared to zero.

The Format Code identifies the parameter list format. For CD-RW, the Format Code shall be set to seven (111b).

The Interleave Value identifies the interleave to be used when formatting. For CD-RW, Interleave Value shall be cleared to zero.

The FORMAT UNIT Command parameter list (Table 121) consists of three descriptors: the Format List Header, the Initialization Pattern Descriptor, and the Format Descriptor.

Table 121 - Format Unit Parameter List

Bit Byte	7	6	5	4	3	2	1	0
0	Format List Header							
1	Initialization Pattern Descriptor							
2	Format Descriptor							

Table 122 - Format List Header

Bit Byte	7	6	5	4	3	2	1	0	
0	Reserved								
1	FOV	DPRY	DCRT	STPF	IP	DSP	IMM	VS	
2	(MSB)	Format Descriptor Length							
3								(LSB)	

FOV is not used and shall be cleared to zero.

DPRY is not used and shall be cleared to zero.

DCRT is not used and shall be cleared to zero.

STPF is not used and shall be cleared to zero.

IP is not used and shall be cleared to zero.

DSP is not used and shall be cleared to zero.

IMM indicates that GOOD status shall be returned once the command has been decoded and the format operation has begun.

VS is not used and shall be cleared to zero.

The Format Descriptor Length shall be set to 8 when formatting CD-RW medium.

The Initialization Pattern Descriptor (Table 123) is not used for formatting CD-RW medium and shall be cleared to zeros.

Table 123 - Initialization Descriptor

Bit Byte	7	6	5	4	3	2	1	0
0	0							
1	0							
2	0							
3	0							

Table 124 - CD-RW Format Descriptor

Bit Byte	7	6	5	4	3	2	1	0																
0	Sess	Grow	Reserved																					
1	Reserved																							
2	Reserved																							
3	Reserved																							
4	(MSB) <span style="float: right;">(LSB)</span>																							
5									Format Size															
6																								
7																								

If both the Grow and Session bits are set to zero the format operation shall format (Format Size) user data blocks. Format Size must be integrally divisible by the Packet Size field in the WRITE PARAMETERS mode page. The first formatted user data block shall be LBA 0. Existing information on the disc may be overwritten. After the format, a single session containing a single, fixed packet track will exist on the medium.

If the Grow bit is set to zero and the Session bit is set to 1 the format operation shall create a new session that contains (Format Size) user data blocks. Format Size must be integrally divisible by the Packet Size field in the WRITE PARAMETERS mode page. If the last session on the disc is not complete when this command is issued, a CHECK CONDITION status shall be generated.



A Grow bit of 1 indicates that the final session shall be "grown" to (Format Size) from its original size. This is accomplished by appending packets to the existing session, writing a new lead-out, and updating the PMA and lead-in to change the track size to reflect the new size. Data in existing packets shall not be affected. If the Format Size is smaller than the existing size, a check condition status shall be returned. The order of updating the PMA, lead-in, lead-out, and data area is not specified.

The session bit shall be ignored when the Grow bit is set.

If the Multi Session Field (see Table 110) in the Write Parameter Page is 11b, the drive shall erase the remaining area of the disc.

**Table 125 - Recommended errors for FORMAT UNIT Command**

Error	Reference
Deferred Errors	Sub-clause A.1
General Errors	Table A.2
Media Access Errors	Table A.3
Write Errors	Table A.4
FORMAT COMMAND FAILED	Table A.1
CANNOT FORMAT MEDIUM - INCOMPATIBLE MEDIUM	Table A.1

## 6.2.5. READ BUFFER CAPACITY Command

The READ BUFFER CAPACITY command checks the total length of buffer and the length of blank area.

**Table 126 - READ BUFFER CAPACITY Command Descriptor Block**

Bit Byte	Bit 7	Bit 6	Bit 5	Bit 4	Bit 3	Bit 2	Bit 1	Bit 0
0	Operation Code (5Ch)							
1	Reserved			Reserved				
2	Reserved							
3	Reserved							
4	Reserved							
5	Reserved							
6	Reserved							
7	(MSB) Allocation Length							
8	(LSB)							
9	Control							

The drive reports the length of the buffer during Session at Once Recording or Track at Once Recording. If the READ BUFFER CAPACITY command is issued in a condition except Session at Once Recording or Track at Once Recording, the Blank Length of Buffer field may be invalid.

An Allocation Length of zero is not an error.

The READ BUFFER CAPACITY data shown below is sent in response to this command.

**Table 127 - READ BUFFER CAPACITY data**

Bit Byte	Bit 7	Bit 6	Bit 5	Bit 4	Bit 3	Bit 2	Bit 1	Bit 0
0	(MSB) Data Length							
1	(LSB)							
2	Reserved							
3	Reserved							
4	(MSB) The Length of Buffer							
5								
6								
7	(LSB)							
8	(MSB) Blank Length of Buffer							
9								
10								
11	(LSB)							

The Length of Buffer indicates the whole capacity of the buffer in bytes.

The Blank Length of Buffer indicates the length of unused area of the buffer in bytes.

Table 128 - Recommended errors for READ BUFFER CAPACITY Command

Error	Reference
Deferred Errors	Sub-clause A.1
General Errors	Table A.2

## 6.2.6. READ DISC INFORMATION Command

It is not possible to completely characterize some incomplete CD-R/RW discs with the information from the READ TOC/PMA/ATIP command. The READ DISC INFORMATION Command provides information about all discs: CD-ROM, CD-R, and CD-RW, including all incomplete CD-R/RW discs.

Table 129 - READ DISC INFORMATION Command Descriptor Block

Bit Byte	7	6	5	4	3	2	1	0
0	Operation Code (51h)							
1	Reserved							
2	Reserved							
3	Reserved							
4	Reserved							
5	Reserved							
6	Reserved							
7	(MSB)		Allocation Length					
8							(LSB)	
9	Control Byte							

The number of Disc Information Block bytes returned is limited by the Allocation Length parameter of the CDB. An Allocation Length of zero is not an error.

The Disc Information Block has two parts; a static disc information area, as shown in Table 130, and an OPC response shown in Table 134.

Table 130 - Disc Information Block

Bit Byte	7	6	5	4	3	2	1	0
0	(MSB) Data Length (LSB)							
1								
2	Reserved			Erasable	State of last Session		Disc Status	
3	Number of First Track on Disc							
4	Number of Sessions							
5	First Track Number in Last Session							
6	Last Track Number in Last Session							
7	DID_V	DBC_V	URU	Reserved				
8	Disc Type							
9	Reserved							
10	Reserved							
11	Reserved							
12	(MSB) Disc Identification (LSB)							
13								
14								
15								
16	(MSB) Last Session lead-in Start Time MSF (LSB)							
17								
18								
19								
20	(MSB) Last Possible Start Time for Start of lead-out MSF (LSB)							
21								
22								
23								
24	(MSB) Disc Bar Code (LSB)							
...								
31								
32	Reserved							
33	Number of OPC Table Entries							
34 - n	OPC Table Entries							

Data Length is the number of bytes available in both the recording information area and the appended OPC table. Data Length excludes itself.

Disc Status field indicates the status of the disc and is shown in Table 131

**Table 131 - Disc Status**

Status	Definition
00b	Empty
01b	Incomplete disc (Appendable)
10b	Complete (CD ROM or last session is closed and has no next session pointer)
11b	Reserved

The State of Last Session field is defined in Table 132.

**Table 132 - State of Last Session**

Session State	Definition
00b	Empty Session
01b	Incomplete Session
10b	Reserved
11b	Complete Session (only possible when Disc Status is Complete)

The Erasable bit, when set to one, indicates that CD-RW medium is present. Otherwise, CD-RW medium is not present.

The Number of First Track identifies the first track number in the TOC or PMA. Valid track numbers are from 01h to 63h. The first track number is not required to be one. A disc may start with any valid track number. The track numbers between the first and last track number shall be in contiguous ascending order, except for lead-out areas.

The Number of Sessions on the disc refers to all complete sessions plus any incomplete or empty sessions. A Blank Disc will always have a session count equal to one.

First Track Number in Last Session is the track number of the first track in the last session. This is inclusive of the invisible track.

Last Track Number in Last Session is the track number of the last track in the last session. This is inclusive of the invisible track.

The DID\_V (Disc ID Valid) bit, when set to one, indicates that the Disc Identification field is valid.

The DBC\_V (Disc Bar Code Valid bit, when set to one, indicates that the Disc Bar Code field (bytes 24 through 31) is valid.

The URU (Unrestricted Use Disc) bit, when set to one, indicates that the mounted CD-R/RW disc is defined for unrestricted use. When the Unrestricted Use Disc bit is set to zero, the mounted CD-R/RW disc is defined for restricted use. To record data to the mounted disc the appropriate Host Application code shall be set through the Write Parameters Page. A Host Application Code of zero may be used to indicate a restricted use disc - general purpose.

The Disc Type field specifies the type of data on the whole disc. A disc has only one disc type. The disc type shall be obtained from the PMA or from the A0/PSEC field in the TOC of the first session in which there is at least one data track.

In the case of a session that contains no data track (only audio), A0/PSEC field in the TOC of the session is always 00h regardless of actual disc type.

The disc type shall be determined from the following sequences:

- 1) Disc ID (Disc Type) as written in PMA.
- 2) From the first Complete Session that includes at least one data track.
- 3) From the first session of a Complete Disc.
- 4) The Disc type is NOT decided, the Disc Type field of Disc Information shall contain FF. (undefined)

**Table 133 - Disc Type Field - PMA**

Disc Type Code	Disc Type
00h	CD-DA or CD-ROM Disc
10h	CD-I Disc
20h	CD-ROM XA Disc
FFh	Undefined
All Other Values	Reserved

The Disc Identification number recorded in the PMA is returned. The Disc Identification Number is recorded in the PMA as a six-digit BCD number. It is returned in the Disc Information Block as a 32 bit binary integer.

The Last Session lead-in Start Time field is an address given in MSF format as defined in sub-clause 4.1.7. This field shall specify the location of the next Lead-in to be recorded. If the disc is Empty as specified in the Disc Status field or has no Complete Session, then the Lead-in Start Time is returned as specified by ATIP. If the last session, which is second or greater, is Empty or Incomplete, this field shall specify the Lead-in Start Time of the Last Session. If the Disc Status is Complete, the Lead-in Start Time shall be FF/FF/FF MSF.

The Last Possible Start Time of lead-out field is an address given in MSF format as specified in sub-clause 4.1.7. If the disc is a Complete disc, the Last Possible Start Time of Lead-out shall be FF/FF/FF MSF.

The Disc Bar Code field contains the Hex value of the bar code if the device has the ability to read Disc Bar Code and a bar code is present. See Table 103.

An OPC (Optimum Power Calibration) Table is attached only if the values are known for the disc. Since OPC values are likely to be different for different recording speeds, each table entry is associated with a recording speed. The Number of OPC Table Entries indicates that [8 x (Number of OPC Table Entries)] bytes follow the first part of the Disc Information. This number shall be the same for all values of Allocation Length. The Number of OPC Table Entries will always be zero for CD-ROM discs and for CD-R/RW discs for which OPC have not yet been determined.

Table 134 - OPC Table Entry

0	Speed (kBytes per second)
1	
2	OPC Values
3	
4	
5	
6	
7	

Speed is in kBytes per second (see Table 105). See SEND OPC Command sub-clause 6.2.12.

The OPC Value field is associated with the speed specified in the speed field, and its content is vendor specific.

Table 135 - Recommended errors for READ DISC INFORMATION Command

Error	Reference
Deferred Errors	Sub-clause A.1
General Errors	Table A.2
Media Access Errors	Table A.3



## 6.2.7. READ MASTER CUE Command

The READ MASTER CUE command reads the Mastering Information from a Master CD. Refer to RIAJ Standard, RIS 105-1994, Operation Rule of CD-R Master for CD.

Note: This document does not define any relationship between the master cue data and data sent with the Send Cue Sheet command.

Table 136 - READ MASTER CUE Command Descriptor Block

Bit Byte	Bit 7	Bit 6	Bit 5	Bit 4	Bit 3	Bit 2	Bit 1	Bit 0
0	Operation Code (59h)							
1	Reserved			Reserved				
2	Reserved							
3	Reserved							
4	Sheet Number							
5	Reserved							
6	(MSB) Allocation Length (LSB)							
7								
8								
9	Control							

The Sheet Number values are shown in Table 137 below.

Table 137 - Sheet Number Values

Sheet Number	Content
00h	Disc Information
01h	Master Cue Sheet
02 ... FFh	Reserved

Allocation Length specifies the maximum number of bytes that are returned. Response data is terminated when allocation length bytes have been transferred or when all data have been transferred to the initiator, whichever is less. An Allocation Length of zero is not an error. If Allocation Length is zero, no data shall be transferred. The data read from the Master CD is transferred in the format shown in Table 138 below.

If no master cue sheet exists on the media, the device shall return CHECK CONDITION status, INCOMPATIBLE MEDIUM INSTALLED.

Table 138 - Master CD response data format

Byte number	Byte 0	Byte 1	Byte 2	Byte 3	Byte 4	Byte 5	Byte 6	Byte 7
0	00h	00h	00h	00h	Sheet Length (byte)			
8	Contents of the Sheet							
...	...							

Table 139 - Recommended errors for READ MASTER CUE Command

Error	Reference
Deferred Errors	Sub-clause A.1
General Errors	Table A.2
Media Access Errors	Table A.3

## 6.2.8. READ TRACK INFORMATION Command

The READ TRACK INFORMATION Command provides information about a track, regardless of its status.

**Table 140 - READ TRACK INFORMATION Command Descriptor Block**

Bit Byte	7	6	5	4	3	2	1	0
0	Operation Code (52h)							
1	Reserved							Track
2	(MSB) Logical Block Address/ Track Number (LSB)							
3								
4								
5								
6								
7	(MSB) Allocation Length (LSB)							
8								
9	Control Byte							

The Track bit in byte 1 is used to specify the contents of bytes 2 through 5 of the CDB. If the Track bit is set to zero, then bytes 2 through 5 contain a Logical Block Address. If the Track is set to one, then bytes 2 through 5 contain a track number.

The Logical Block Address/Track Number field, Bytes 2 through 5 are defined in Table 141.

**Table 141 - Track Number/LBA Field definition**

Track Bit	Logical Block Address/Track Number	Track Number Used for Track Information
0	Logical Block Address	$T_{LBA}$ , where $T_{LBA}$ is the number of the track which contains the block associated with Logical Block Address.
1	$T_{CDB}$ , a valid track number	$T_{CDB}$
1	FFh	$T_{INV}$ , where $T_{INV}$ is the track number of the invisible track

The number of Track Information Block bytes returned is limited by the Allocation Length parameter of the CDB. An Allocation Length of zero is not an error.

The format and content of the Track Information Block is shown in Table 142.

**Table 142 - Track Information Block**

Bit Byte	7	6	5	4	3	2	1	0
0	(MSB) Data Length (LSB)							
1								
2	Track Number							
3	Session Number							
4	Reserved							
5	Reserved		Damage	Copy	Track Mode			
6	RT	Blank	Packet	FP	Data Mode			
7	Reserved							NWA_V
8	(MSB) Track Start Address (LSB)							
9								
10								
11								
12	(MSB) Next Writable Address (LSB)							
13								
14								
15								
16	(MSB) Free Blocks (LSB)							
17								
18								
19								
20	(MSB) Fixed Packet Size (LSB)							
21								
22								
23								
24	(MSB) Track Size (LSB)							
25								
26								
27								

Data length field specifies the length, in bytes, of the requested data to be transferred in response to the command. The data length value does not include the data length field itself. If the Allocation length specified is less than the data length, the response shall be truncated at the allocation length specified. This truncation shall not cause a Check Condition status to be presented. The Data Length is not modified when the allocation length is insufficient to return all of the response data available.

Track Number is the track number for all of the information in this structure.

Session Number is the number of the session containing this track.

The Copy bit indicates that this track is a second or higher generation copy.

The Damage bit, when set to one, and the NWA\_V is set to zero, the track shall be considered "not closed due to an incomplete write." An automatic repair may be attempted by the drive when the CLOSE TRACK/SESSION command is

issued. The Damage bit, when set to one, and the NWA\_V is set to one, an automatic repair may be attempted by the drive when the next command that requires writing to the track is issued. If the repair is successful, the Damage bit shall be set to zero.

Track Mode is the control nibble as defined for mode 1 Q sub-channel for this track. See Figure 3 and Table 61

If the RT bit is zero, then the track is not reserved, otherwise the track is reserved. Reserved indicates that a PMA entry indicating the track's start and end addresses exists.

The Blank bit, when set to one, indicates that the track contains no written data. Tracks with the Track Descriptor Block recorded shall not be considered blank.

The Packet bit is valid only when the RT bit is set to one or the track indicated is the incomplete track. The Packet bit, when set to one, indicates that this track is to be written only with packets.

The FP (Fixed Packet) bit is valid only when the Packet bit is set to one. When the Packet bit is set to one and the FP bit is also set to one, then the track is to be written only with fixed packets. When the Packet bit is set to one and the FP bit is set to zero, then the track is to be written only with variable packets.

When writing, certain parameters may be set via the write parameters page. The state of the track determines what parameters must be set and which parameters in the mode page must match. Required Write Parameters are defined in Table 143.

**Table 143 - Write Parameter Restrictions due to Track State**

RT	Blank	Packet	Write Parameter Restrictions
0	0	0	Can't write to stamped disc, or during track at once on invisible track, or writing session at once mode
0	0	1	Write type set to packet; all parameters common to READ TRACK INFO and the write parameters mode page must match.
0	1	0	Write type may be set to packet or TAO. All other parameters shall be changeable. If this track is the first track of a Session, then Session at Once is allowed.
0	1	1	Invalid State
1	0	0	Can't write to recorded track or during track at once on reserved track.
1	0	1	Write type set to packet; all parameters common to READ TRACK INFO and the write parameters mode page must match.
1	1	0	Write type set to TAO. Track mode set to same as READ TRACK INFO. Copy bit may be set only if copyright bit in track mode is clear. All other common parameters must match.
1	1	1	Write type set to Packet. Track mode set to same as READ TRACK INFO. Copy bit may be set only if copyright bit in track mode is clear. FP and packet size are changeable. All other common parameters must match.

When RT, Blank and Packet bits are set to one, FP bit of a Read Track Information result data is set to zero.

Data Mode defines the track content. Data Mode is defined in Table 145.

Table 144 - Track Status Indications

RT	Blank	Packet	FP	Write Method	Track Status
0	0	0		Uninterrupted/TAO/SAO	Complete/During TAO/SAO
0	0	1	0	Variable	Incomplete
0	0	1	1	Fixed	Incomplete
0	1	0	0	TAO/Variable/Fixed(*)	Invisible
0	1	1	0	-	(invalid)
0	1	1	1	-	(invalid)
1	0	0		TAO	Complete/During TAO
1	0	1	0	Variable	Complete/Partially Recorded Reserve
1	0	1	1	Fixed	Complete/Partially Recorded Reserve
1	1	0	-	TAO	Empty Reserved
1	1	1	0	Variable/Fixed	Empty Reserved
1	1	1	1	-	(invalid)

\* In case last session is empty, SAO is also valid.

Table 145 - Data Mode

Value	Definition
1	Mode 1 (ISO/IEC 10149)
2	Mode 2 (ISO/IEC 10149 or CD-ROM XA)
Fh	Data Block Type unknown (no track descriptor block)
0, 3 - Eh	Reserved

If NWA\_V is zero, then the next writable address field is not valid. Otherwise the next writable address field is valid. NWA\_V shall be set to zero if the track is not writable for any reason.

The Track Start Address is the starting address for the specified track.

The Next Writable Address, if valid, is the LBA of the next writable user block in the track specified by the LBA/Track Number field in the CDB. Next Writable Address shall be associated with the RT, Blank, Packet and FP bits as defined in Table 146. If the write type is Raw, the Next Writable Address may be a negative number as required to point to the start of the first lead-in (see Table 173). When streaming in any write type, the Next Writable Address shall be the next user data block the drive expects to receive if no underrun occurs.

Table 146 - Next Writable Address Definition

RT	Blank	Packet	FP	NWA_V	Definition
0	0	0	-	0 *4	LBA that shall be specified by next write command *2
0	0	1	0	1 *1	LBA that shall be specified by next write command *2
0	0	1	1	1 *1	LBA that shall be specified by next write command *2, *3
0	1	0	0	1	LBA of the first data block after pre-gap *5
0	1	1	0	-	-
0	1	1	1	-	-
1	0	0	-	0 *4	LBA that shall be specified by next write command *2
1	0	1	0	1 *1	LBA that shall be specified by next write command *2
1	0	1	1	1 *1	LBA that shall be specified by next write command *2, *3
1	1	0	-	1	LBA of the first data block after pre-gap
1	1	1	0	1	LBA of the first data block after pre-gap
1	1	1	1	-	-

\*1 - When "Free Blocks" is 0 (data full), NWA\_V is 0.

\*2 - NWA shall be taken account of data blocks in buffer that has not yet been written to media. If the drive can write the data of next write command without interrupting of current data streaming (no underrun condition), NWA shall be contiguous to last address data in buffer. If WCE in Mode Cache Page is zero, NWA shall be taken account of Link Blocks (2 Run-out blocks, 1 Link block and 4 Run-out blocks) in case of Addressing Method-1.

\*3 - NWA shall follow the Addressing Method-2 if Method-2 bit in Mode CD Capabilities and Mechanical Status Page is set to one.

\*4 - During TAO (SAO), NWA\_V is 1.

\*5 - In the case of SAO NWA shall be the first block after lead-in for the first track of session.

The Free Blocks field represents the maximum number of user data blocks available for recording in the track. This field shall be computed as follows: First, the Available Track Space (ATS) shall be computed. For the invisible track,  $ATS = (\text{StartTimeofLastPossibleLead-out}) - NWA + 5$ . For a reserved track,  $ATS = (\text{PMASopTime}) - NWA + 5$ . If

the track is reserved for, or written with, fixed packets,  $\text{FreeBlocks} = \text{IP}\left(\frac{ATS}{\text{PacketSize} + 7}\right) \cdot \text{PacketSize}$ . Otherwise,

$$\text{FreeBlocks} = \text{ATS} - 7$$

Note: The StartTimeofLastPossibleLead-out is the last possible location of the link block at the start of the lead-out. If a disc is fully recorded, the PMA entry for the last track will be equal to the StartTimeofLastPossibleLead-out.

Addressing within fixed packet written tracks is translated by the drive for reading and writing. The NWA shall also reflect this translation:  $NWA_{\text{Method2}} = NWA_{\text{Method1}} - 7 \cdot \text{IP}\left(\frac{NWA_{\text{Method1}} - \text{TrackStartAddress}}{\text{PacketSize} + 7}\right)$ . Method 1 is the physical address. Method 2 is used on fixed packet written tracks to hide the link areas from the initiator. The TrackStartAddress is always a physical address, even if prior tracks are recorded with Method 2. IP() is the integer part of the value.

The Fixed Packet Size is valid only when the Packet and the FP bits are both set to one.

If the disc is stamped, then DAMAGE = 0, BLANK = 0, RT = 0, and NWA\_V = 0.

Track Size is the number of user data blocks in the track. The track size shall be computed as follows: First, compute the Complete Track Size (CTS). For an incomplete track,

CTS = (StartTimeofLastPossibleLeadout) – PMATrackStart + 5. For a reserved track,

CTS = (PMAStopTime) – PMAStartTime + 5. If the track is reserved for, or written with, fixed packets,

$$\text{TrackSize} = \text{IP}\left(\frac{\text{CTS}}{\text{PacketSize} + 7}\right) \bullet \text{PacketSize} . \text{ Otherwise, } \text{TrackSize} = \text{CTS} - 7$$

NOTE: Read Track Information shall provide certain valid fields for a disc with the Unrecordable status: Track Number, Session Number, Track Mode, Data Mode, Track Start Address.

NOTE: The Track Size number may not be exact for the tracks that do not have a PMA entry.

Table 147 - Recommended errors for READ TRACK INFORMATION Command

Error	Reference
Deferred Errors	Sub-clause A.1
General Errors	Table A.2
Media Access Errors	Table A.3



## 6.2.9. REPAIR TRACK command

A track which has been defined for packet writing may be damaged due to an incomplete packet at the end of written data. This may be caused by a RESET or a power-fail condition during a packet write. The REPAIR TRACK (Table 148) command will fill a fixed length packet to its correct user data length and add run-outs. Variable length packets will simply be completed with run-outs. The user data in the repaired packet must be rewritten as the repaired packet is not readable. The recovery indicated here only allows the track to become writable again.

Table 148 - REPAIR TRACK Command Descriptor Block

Bit Byte	7	6	5	4	3	2	1	0
0	Operation Code (58h)							
1	Reserved							
2	Reserved							
3	Reserved							
4	Reserved							
5	Track Number							
6	Reserved							
7	Reserved							
8	Reserved							
9	Control Byte							

The Track Number specifies the track which requires repair.

Behavior of this command with non-packet written tracks is vendor specific.

Table 149 - Recommended errors for REPAIR TRACK Command

Error	Reference
Deferred Errors	Sub-clause A.1
General Errors	Table A.2
Media Access Errors	Table A.3
Write Errors	Table A.4

## 6.2.10. RESERVE TRACK Command

The RESERVE TRACK Command allows reservation of disc space for a track. A PMA entry for the track shall be either written or cached for writing prior to disc removal.

Table 150 - RESERVE TRACK Command Descriptor Block

Bit Byte	7	6	5	4	3	2	1	0
0	Operation Code (53h)							
1	Reserved							
2	Reserved							
3	Reserved							
4	Reserved							
5	(MSB) Reservation Size (LSB)							
6								
7								
8								
9	Control Byte							

The Reservation Size field contains the number of user blocks desired for the track reservation. The actual number of blocks allocated shall be according to the Write Parameters Mode Page. The PMA start time shall reflect the appropriate pre-gap, as determined by the previous track's mode and the settings of the Write Parameters mode page. Table 151 specifies the PMA stop time:

Table 151 - Track reservation sizing

Write Parameters Page Write Type Value	PMA Stop Time
Session-at-once	CHECK CONDITION status is returned and sense is set to ILLEGAL REQUEST, COMMAND SEQUENCE ERROR
Track-at-once	Reserves the number of user blocks specified. The PMA stop time shall be $PMA_{Start} + ReservationSize + 2$
Variable Packet	Reserve behaves as in track-at-once.
Fixed Packet	Set $p = \frac{ReservationSize}{PacketSize}$ packets, where packet size is taken from the Write Parameters Mode Page. If p is an integer, then the reservation is performed and the PMA stop time shall be $PMA_{Start} + (PacketSize + 7) \cdot p - 5$ . Otherwise, the reservation is not performed, CHECK CONDITION status is returned, and sense is set to ILLEGAL REQUEST, INVALID FIELD IN COMMAND PACKET. Enough space for reservation size user data packets shall be reserved.

The invisible track is known to have track number N+1 only because the track number of the track immediately preceding it has track number N. Tracks shall only be reserved from the beginning of the invisible track. Each track prior to the invisible track has a track number defined in the PMA. After the reservation is done, the track number given to the new track is the current track number of the invisible track. The number of the invisible track is increased by one following a reservation.

If the Reservation Size is smaller than four seconds, excluding pre-gap length, the drive shall return CHECK CONDITION status and sense set to 05/24/00 Invalid Field in CDB.

Reserving shall be allowed when the track is invisible. Attempting to reserve an existing incomplete track shall cause a CHECK CONDITION status, ILLEGAL REQUEST, COMMAND SEQUENCE ERROR. Attempting to reserve a track

when the invisible track is partially recorded shall cause a CHECK CONDITION status, ILLEGAL REQUEST, COMMAND SEQUENCE ERROR.

Reserving a track when the Write Type is set to packet (See Table 108) shall cause the TDB to be written.

**Table 152 - Recommended errors for RESERVE TRACK Command**

Error	Reference
Deferred Errors	Sub-clause A.1
General Errors	Table A.2
Media Access Errors	Table A.3
Write Errors	Table A.4

## 6.2.11. SEND CUE SHEET Command

A Session-at-once recording is written beginning with the lead-in and continuing through the lead-out. Only user data will be sent with the write commands, so a guide structure is required by the CD-R/RW device in order to control the recording process. This guide structure is called the cue sheet. The cue sheet is constructed in the initiator and sent to the device.

Table 153 - SEND CUE SHEET Command Descriptor Block

Bit	7	6	5	4	3	2	1	0
Byte								
0	Operation Code (5Dh)							
1	Reserved							
2	Reserved							
3	Reserved							
4	Reserved							
5	Reserved							
6	(MSB) Cue Sheet Size (LSB)							
7								
8								
9	Control Byte							

The Cue Sheet Size parameter is the number of bytes in the cue sheet to be sent to the device. The entire cue sheet must be received by the device prior to beginning the write process. If the device cannot accept and buffer the entire cue sheet, then CHECK CONDITION is returned and sense is set to ILLEGAL REQUEST, INVALID FIELD IN COMMAND DESCRIPTOR BLOCK.

If the Write Parameters Mode Page does not have Write Type set to Session-at-once, then CHECK CONDITION status is returned and sense key is set to ILLEGAL REQUEST, COMMAND SEQUENCE ERROR.

If the Write Mode in the Write Parameter Mode page, is changed from session at once, the Q sheet may not be available.

## 6.2.11.1. CUE SHEET FORMAT

The Cue Sheet contains information required to specify the layout of a disc to be written, and must be sent to the drive via the SEND CUE SHEET command before writing data to the disc.

The Cue Sheet format is shown in Table 154.

Table 154 - Cue Sheet format

Byte Number	Cue Sheet Data
0	Mixture of Information of absolute disc location, catalogue Code, and ISRC (total m lines)
...	
(m-1)* 8	

If the Catalogue Code is to be recorded, it shall be described at the beginning of the Cue sheet.

If the ISRC is to be recorded, it shall be described immediately preceding each Track's information in the Cue Sheet.

For the Cue sheet, the lead-out start time shall be the last entry.

## 6.2.11.2. Information of the absolute disc location

The drive writes a disc according to this information. This information defines the following parameters:

1. Generation of Sub-channel P and Q channel.
2. Format and block size of the data transferred by the WRITE command

Table 155 - Sample CUE SHEET

Byte Number (Hex)	CTL/ ADR  (hex)	TNO  (hex)	INDEX  (hex)	DATA FORM  (hex)	SCMS  (hex)	ABSOLUTE TIME		
						MIN	SEC	FRAME
00 (lead-in)	01 *5	00	00 *1	01 *5	00	00 *1	00 *1	00 *1
08 (TNO:01)	01	01	00	01	00	00	00	00
10 (TNO:01) *2	01	01	01	00	00	00	02	00
18 (TNO:02)	01	02	00	C0	00	07	29	71
20 (TNO:02)	01	02	01	C0	00	07	31	71
28 (TNO:03)	01	03	01	C0	00	14	18	03
30 (NO:04) *4	41	04	00	10	00	19	06	62
38 (TNO:04)	41	04	01	10	00	19	09	62
40 (TNO:05) *4	41	05	00	11	00	27	37	10
48 (TNO:05)	41	05	01	10	00	27	40	10
50 (TNO:06)	01	06	00	01	80 *6	38	53	23
58 (TNO:06)	01	06	01	00	80 *6	38	55	23
60 (lead-out)	01 *5	AA	01 *3	01 *5	00	56	37	46

All numbers are Hex.

## NOTES:

- 1) Always zero for lead-in.
- 2) The first information track on a disc is preceded by a pause encoding of 2-3 seconds. (If the first track is a Data track, this track does not contain pause encoding, but always contains a "pause" of 2 seconds of pre-gap).
- 3) Always 01h for lead-out
- 4) Pre-gap
- 5) For the lead-in and lead-out area the DATA FORM shall be one. For lead-in, data form and control mode of the first track is specified. For lead-out, data form and control mode of last track is specified automatically. All data for both lead-in and lead-out shall be generated by the drive.
- 6) Copy

This information is composed of data units of 8 bytes (1 line). The information consists of three parts:

- 1) The lead-in area, and contains only one data unit.
- 2) The Program area, that contains data units.
- 3) The lead-out area, and contains one or more data units.

The data units in Program Area and lead-out area are in Absolute Time order from the start time of index = 0 of the first track of the session.

Each data unit of Program area and lead-out area indicates that the value of each field (CONTROL, TNO, X, DATA FORM or ZERO) changes at the time shown in ABSOLUTE TIME field.

**Table 156 - Cue Sheet Data**

CTL/ ADR (hex)	TNO (hex)	INDEX (hex)	DATA FORM (hex)	SCMS (hex)	ABSOLUTE TIME		
					Min	Sec	Frame
01	02	01	C0	00	07	31	71
01	03	01	C0	00	14	18	03

The above data unit indicates that the value of TNO changes from 02 to 03 when ABSOLUTE TIME is 14/18/03 MSF.

#### 6.2.11.2.1. Control/Address Field

The CTL/ADR byte contains the Control field in the upper 4 bits and the ADR in the lower 4 bits. Refer to Table 157.

**Table 157 - CTL/ADR byte**

7	6	5	4	3	2	1	0
CTL Field				ADR Field			

#### 6.2.11.2.2. CTL Field(upper 4 bits)

The CTL (Control) field contains 4 bits that define the kind of information in a track. The definition is shown in Table 158.

**Table 158 - Control Field**

Bit 7	Bit 6	Bit 5	Bit 4	Definition
0	0	x	0	2 audio channels without pre-emphasis
1	0	x	0	4 audio channels without pre-emphasis
0	0	x	1	2 audio channels with pre-emphasis of 50/15 $\mu$ s.
1	0	x	1	4 audio channels with pre-emphasis of 50/15 $\mu$ s.
0	1	x	0	Data track
x	x	0	x	digital copy prohibited
x	x	1	x	digital copy permitted

The bits of the Control field (except for the copy bit) shall only be changed during an actual pause (Index = 00) of at least 2 seconds and during lead-in area.

## 6.2.11.2.3. ADR Field(lower 4 bits)

Table 159 defines the codes found in the ADR Field

Table 159 - ADR Field

Bit 3	Bit 2	Bit 1	Bit 0	Definition
0	0	0	1	start time at TNO/IDX
0	0	1	0	CATALOG CODE
0	0	1	1	ISRC CODE

All other codes are reserved for future use.

Control must be the same for each entry associated with a particular track except for first part of pre-gap.

## 6.2.11.2.4. TNO

The TNO field indicates track number expressed in HEX. Each track has a minimum length of 4 seconds, not including the pause length preceding the track.

## 6.2.11.2.5. INDEX Field

The index number expressed in HEX. The drive supports only 00h ~ 63h.

## 6.2.11.2.6. DATA FORM

Table 160 defines the data form byte.

Table 160 - Data Form Byte

7	6	5	4	3	2	1	0
Data Form of Sub-channel		Data Form of Main Data					

## 6.2.11.2.7. SCMS (Serial Copy Management System)

Bit 7 of data form of 1 indicates that Copy bit of CONTROL field alternates for Serial Copy Management System (see Table 161). The other 7 bits (Reserved) are zero This bit is effective if Copy bit of the Control Code is zero.

Table 161 - SCMS Byte

7	6	5	4	3	2	1	0
Alternate Copy bit	Reserved						

## 6.2.11.2.8. DATA FORM OF MAIN DATA

The DATA FORM OF MAIN DATA field specifies the format of the main data to be sent by a WRITE command to write on the disc. Currently available data formats are 1.) CD-DA, 2.) CD-ROM mode 1, 3.) CD-ROM XA, and CD-I. For lead-in and lead-out area data are generated automatically.

## 6.2.11.2.9. CD-DA Data Form

Figure 13 defines a CD-DA Data Form for one frame.

Data Form	Data of One Frame	Data Size
00h	2352	2352
01h	2352	0

Figure 13 - CD (CD-DA)

The CD-DA data format, Table 162, is as follows;

Table 162 - CD-DA Data format (1 Sample)

Bit Byte	7	6	5	4	3	2	1	0
n*4+0 (L ch)	L7	L6	L5	L4	L3	L2	L1	L0
n*4+1 (L ch)	L15	L14	L13	L12	L11	L10	L9	L8
n*4+2 (R ch)	R7	R6	R5	R4	R3	R2	R1	R0
n*4+3 (R ch)	R15	R14	R13	R12	R11	R10	R9	R8

n = 0,1, .. ,587

1 Second = 75 Frames

1 Frame = 588 Samples

1 Sample = 4 bytes (16 bits L, Rch)

## 6.2.11.2.10. CD-ROM mode 1 Form

Figure 14 defines the form for CD-ROM mode 1.

Data Form	Sync/ Header	Data of One Frame	EDC/ECC Area	Data Size
10h	16 *2	2048 *1	288 *2	2048
11h	16 *3	2048 *1	288 *3	2352
12h	16 *2	2048 *3	288 *2	2048
13h	16 *3	2048 *3	288 *3	2352
14h	16 *2	2048 *2	288 *2	0

Figure 14 - CD-ROM mode 1



## 6.2.11.2.11. CD-ROM XA, CD-I Form

Figure 15 defines the form for CD-ROM XA, CD-I.

Data Form	Sync/ Header	Sub Header	Data of One Frame	EDC/ECC Area	Data Size	
20h	Form 1	16 *2	8 *1	2048 *1	280 *3	2336
	Form 2	16 *2	8 *1	2324 *1	4 *3	2336
21h	Form 1	16 *3	8 *1	2048 *1	280 *3	2352
	Form 2	16 *3	8 *1	2324 *1	4 *3	2352
22h	Form 1	16 *2	8 *1	2048 *3	280 *3	2336
	Form 2	16 *2	8 *1	2324 *3	4 *3	2336
23h	Form 1	16 *3	8 *1	2048 *3	280 *3	2352
	Form 2	16 *3	8 *1	2324 *3	4 *3	2352
24h	Form 1	NA	NA	NA	NA	NA
	Form 2	16 *2	8 *2	2324 *2	4 *2	0

Figure 15 - CD-ROM XA, CD-I

Reserved Area: The Reserved Area contains 4 bytes that are reserved for quality control during the disc production process. In case of Generate Zero, the drive generates zero data of 4 bytes for this area.

## 6.2.11.2.12. CD-ROM mode 2

Figure 16 defines the form for CD-ROM mode 2.

Data Form	Sync/ Header	Data of One Frame	Data Size
30h	16 *2	2336 *1	2336
31h	16 *3	2336 *1	2352
32h	16 *2	2336 *3	2336
33h	16 *3	2336 *3	2352
34h	16 *2	2336 *2	0

Figure 16 - CD-ROM Mode 2

Notes for all forms:

1. Read Buffer: The data is sent by the initiator.
2. Generate Data: The drive generates the data in this area. The initiator shall not send the data for this area. All sectors in the program area shall have an associated write, even if all data for the sector is to be generated by the drive. Zero bytes shall be transferred for such sectors.
3. Ignore Buffer: The drive receives the data for this area from the initiator with Write command. However, the drive ignores the data and generates data for this area.

## 6.2.11.3. Data Form of Sub-Channel

The DATA FORM OF SUB-CHANNEL (Table 163) field specifies the format of the sub-channel data stored in the inner buffer by WRITE command to write on the disc.

Table 163 - Data Form of Sub-channel

Data Form		Data of One Frame				Data Size
Bit 7	Bit 6					
0	0	96 *1				0
0	1	96 *2				96
1	0	Reserved				
1	1	24 Pack *3	24 Pack *3	24 Pack *3	24 Pack *3	96

Notes:

- 1) Generate zero data
- 2) RAW Data
- 3) PACK DATA, Initiator sends packed data. The drive writes R-W. The drive calculates and overwrites ECC, and performs Interleaving for each PACK.

The Sub-channel data is placed at the end of each Frame of main data. Figure 17 shows the relationship of Main Data and sub-channel data.

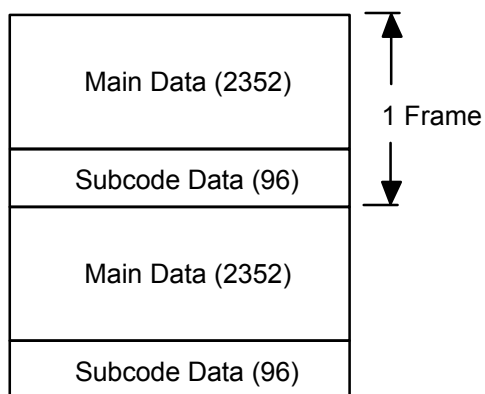

Data transferred by WRITE command

Figure 17 - Location of Sub-channel Data

The P and Q sub-channel information contained within the Subcode Data shall be ignored. The P and Q sub-channel information is generated by the drive and based on the content of the cue sheet.

## 6.2.11.4. Absolute Time

The time shown at Min, Sec, and Frame gives the changing point of the CONTROL, TNO, X, DATA FORM or SCMS field. These values are given in absolute time scale.

## 6.2.11.5. Session Format

The Session Format is used for the identification of the type of disc. Refer to Table 112 - Session Format Codes.

### 6.2.11.6. Pre-gap

If a Data track is preceded by a different mode of track (such as an audio track) or if the mode number of CD-ROM changes, this Data track starts with an extended pre-gap. A pre-gap is placed at the head of a Data track, also is belonging to the Data track. A pre-gap does not contain actual user data. The pre-gap is encoded as "pause."

An extended pre-gap is divided into two parts. The first part of the extended pre-gap has a minimum 1 second of data, and it is encoded according to the data structure of previous track. The second part has a minimum 2 seconds data, and this data track is encoded according to the same data structure as the other parts.

### 6.2.11.7. Post-gap

If a Data track is followed by another kind of track (such as an audio track), this Data track ends with a post-gap. A post-gap is placed at the end of a Data track, and is part of the Data Track. A post-gap does not contain actual user data. The minimum length of post-gap is 2 seconds. The drive does not perform any action for a Post-gap.

### 6.2.11.8. Catalog Number

Table 164, Catalog Number, indicates the catalog number of a disc. The number uses UPC/EAN-code (BAR coding). If no catalog number is used, it shall be omitted. The format is as follows;

**Table 164 - Catalog Number (N1..N13)**

CTL/ ADR	Catalog Number						
Byte 0	Byte 1	Byte 2	Byte 3	Byte 4	Byte 5	Byte 6	Byte 7
02h	N1	N2	N3	N4	N5	N6	N7
02h	N8	N9	N10	N11	N12	N13	00h

N1-N13 Catalog Number

CTL: 4 bits are zero.

ADR: 0010b

Catalog Number: ASCII 13 BYTES

## 6.2.11.9. ISRC

Table 165, ISRC (International Standard Recording Code), is a code that is given to CD-DA tracks. If no ISRC is used, it shall be omitted. If a track has no ISRC, it is not written in the Cue Sheet.

Table 165 - ISRC (I1..I12)

CTL/ ADR	ISRC(International Standard Recording Code)						
byte 0	byte 1	byte 2	byte 3	byte 4	byte 5	byte 6	byte 7
x3h	TNO	I1	I2	I3	I4	I5	I6
x3h	TNO	I7	I8	I9	I10	I11	I12

CTL: 4 bits of Control code are the same as that of disc location of the specified track

ADR: 0011b

TNO: Track number in HEX.

12 letters ISRC (On the Cue Sheet, I1-I12 must be described by valid ASCII characters. See Table 3 for valid codes.

I1-I2: Country Code

I3-I5: Owner Code

I6-I7: Year of recording

I8-I12: Serial Number

Table 166 - Recommended Sense Key, ASC and ASCQ SEND CUE SHEET Command

Error	Reference
Deferred Errors	A.1
General Errors	Table A.2

Errors in mixed case indicate all errors in that class.

Errors in upper case refer to a specific error

## 6.2.12. SEND OPC INFORMATION Command

This command is used to restore the Optimum Power Calibration (OPC) (Table 167) values to the drive for a specific disc. It is used in combination with the READ DISC INFORMATION command (sub-clause 6.2.6.).

Table 167 - SEND OPC INFORMATION Command Descriptor Block

Bit Byte	7	6	5	4	3	2	1	0
0	Operation Code (54h)							
1	Reserved			Reserved			DoOpc	
2	Reserved							
3	Reserved							
4	Reserved							
5	Reserved							
6	Reserved							
7	(MSB) Parameter List Length							
8	(LSB)							
9	Control							

The Parameter List Length must be set to reflect the number of the parameter bytes to be transferred. The minimum number of bytes to transfer is eight (8): 2 byte OPC Speed and 6 bytes of OPC value. This can be extended with a second OPC Speed and Value. In this case the length is 16. See sub-clause 6.2.6. for more information.

The DoOpc bit, when is set to one, indicates the drive shall perform an OPC operation to set the OPC values for the current speed. These OPC values shall become current. A Parameter List may be sent to indicate an initial value of OPC. When the bit is set to zero, the device sets OPC values to those sent in the Parameter List.

A Parameter List Length field of zero shall not be considered an error condition.

The initiator shall transfer one or more OPC table entries(see Table 134). The transfer length shall be 8X (the number of OPC table entries).

The format of the OPC Response Data to be transferred is shown in Table 168.

Table 168 - SEND OPC INFORMATION Paramter List

Bit Byte	7	6	5	4	3	2	1	0
0	(MSB) OPC Speed in kBytes per Second							
1	(LSB)							
2	(MSB)							
3	OPC Value							
4								
5								
6								
7								

Table 169 - Recommended errors for SEND OPC INFORMATION Command

Error	Reference
Deferred Errors	Sub-clause A.1
General Errors	Table A.2
Media Access Errors	Table A.3
Write Errors	Table A.4

## 6.2.13. SYNCHRONIZE CACHE Command

The SYNCHRONIZE CACHE command is shown in Table 170. Also see SCSI-3 BLOCK COMMANDS.

In reference to this command set, this command provides a normal sequence to terminate a Write process, and assures all remaining data in the data buffer has been written to the media.

If the data buffer is empty, issuing this command will result in no data being written to the physical media. This action will not be considered an error. Normal status shall be presented at the completion of the action.

Table 170 - SYNCHRONIZE CACHE Command

Bit Byte	7	6	5	4	3	2	1	0
0	Operation Code (35h)							
1	Reserved			Reserved			Immed	RELADR
2	(MSB) Logical Block Address (LSB)							
3								
4								
5								
6	Reserved							
7	(MSB) Number of Blocks (LSB)							
8								
9	Control							

An Immed (Immediate) bit of one indicates that the device shall return status when the command descriptor block has been validated. An Immediate bit of zero indicates that the status shall not be returned until the operation has been completed. If the Immediate bit is one and the device does not support immediate operation, then the command shall terminate with CHECK CONDITION status. The sense key shall be set to ILLEGAL REQUEST and the additional sense code shall be set to INVALID FIELD IN CDB.

The RELADR bit shall be set to zero.

The Logical Block Address field may be ignored by the drive.

The Number of Blocks field specifies the total number of contiguous logical blocks within the range. A Number of Blocks field, equal to 0, indicates that all remaining logical blocks on the logical unit shall be within the range. This field may be ignored by the drive.

A logical block within the specified range that is not in cache memory is not considered an error.

Table 171 - Recommended errors for SYNCHRONIZE CACHE Command

Error	Reference
Deferred Errors	Sub-clause A.1
General Errors	Table A.2
Media Access Errors	Table A.3
Write Errors	Table A.4

## 6.2.14. WRITE Command

The Write command (Table 172) shall use the WRITE Parameters mode page to determine its operating behavior.

Table 172 identifies the fields and information necessary to perform the WRITE operation. This command definition is identical to the WRITE Command defined in the SCSI-3 Block Command document. Bit definitions supplied in this document are for reference.

Table 172 - WRITE command

Bit Byte	7	6	5	4	3	2	1	0
0	OPERATION CODE (2Ah)							
1	Reserved			DPO	FUA	Reserved		RELADR
2	(MSB) Logical Block Address (LSB)							
3								
4								
5								
6								
7	(MSB) Transfer Length (LSB)							
8								
9	Control							

A DPO (Disable Page Out) bit, set to one, indicates that the target shall assign the logical blocks accessed by this command the lowest priority for being fetched into or retained by the cache. A DPO bit, of one, overrides any retention priority specified in the cache page. A DPO bit of zero indicates the priority shall be determined by the retention priority fields in the cache page. All other aspects of the algorithm implementing the cache replacement strategy are not defined by this International Standard. The drive may ignore this bit.

NOTE: The DPO bit is used to control replacement of logical blocks in the cache memory when the initiator has information on the future usage of the logical blocks. If the DPO bit is set to one, the initiator knows the logical blocks accessed by the command are not likely to be accessed again in the near future and should not be put in the cache memory nor retained by the cache memory. If the DPO bit is zero, the initiator expects that logical blocks accessed by this command are likely to be accessed again in the near future.

A FUA (force unit access) bit, set to one, indicates that the target shall access the media in performing the command prior to returning GOOD status. In the case where the cache contains a more recent version of a logical block than the media, the logical block shall first be written to the media. WRITE commands shall not return GOOD status until the logical blocks have actually been written on the media, and the Write process is complete. This mode may not work with a sequence of writes intended to produce a continuous stream unless tagged queuing is implemented. See the SCSI Architectural Model (X3.270).

An FUA bit of zero indicates that the target may satisfy the command by accessing the cache memory. For WRITE operations, logical blocks may be transferred directly to the cache memory. GOOD status may be returned to the initiator prior to writing the logical blocks to the medium. Any error that occurs after the GOOD status is returned is a deferred error, and information regarding the error is not reported until the following command.

The Logical Block Address field specifies the logical block where the write operation shall begin. In case of WCE=1 (see Write Cache page in SCSI-3 Block Commands) and FUA=0 with variable packet writing, and if the LBA is equal to the Next Writable Address in the same track as a previous Write, then writing should continue without interruption of streaming. If, during streaming, a WRITE command is issued for packet writing with an LBA = NWA+7 the drive shall begin a new packet. If the LBA is equal to the NWA in another track, a synchronize cache may be performed before executing the write command. If the LBA is not any next writable address or a writable CD- E address, the status shall be set to CHECK CONDITION, ILLEGAL REQUEST, INVALID ADDRESS FOR WRITE.



LBA in the range of -45150 (FFFF4FA2h) to -1 (FFFFFFFFh) shall be encoded as a two's complement negative number. Values in the range 0 through ffff4fa1h shall be considered positive values. Values -45150 through 404849 are valid for CD media. Table 173 shows the MSF to LBA mapping.

Table 173- LBA to MSF translation

Condition	Formulae
$-150 \leq \text{LBA} \leq 404849$	$M = \text{IP} \left( \frac{\text{LBA} + 150}{60 \cdot 75} \right)$ $S = \text{IP} \left( \frac{\text{LBA} + 150 - M \cdot 60 \cdot 75}{75} \right)$ $F = \text{IP} (\text{LBA} + 150 - M \cdot 60 \cdot 75 - S \cdot 75)$
$-45150 \leq \text{LBA} \leq -151$	$M = \text{IP} \left( \frac{\text{LBA} + 450150}{60 \cdot 75} \right)$ $S = \text{IP} \left( \frac{\text{LBA} + 450150 - M \cdot 60 \cdot 75}{75} \right)$ $F = \text{IP} (\text{LBA} + 450150 - M \cdot 60 \cdot 75 - S \cdot 75)$
$00/00/00 \leq \text{MSF} \leq 89/59/74$	$\text{LBA} = (M \cdot 60 + S) \cdot 75 + F - 150$
$90/00/00 \leq \text{MSF} \leq 99/59/74$	$\text{LBA} = (M \cdot 60 + S) \cdot 75 + F - 450150$

The RELADR bit shall be set to zero.

The transfer length field specifies the number of contiguous logical blocks of data that shall be transferred. A transfer length of zero indicates that no logical blocks shall be transferred. This condition shall not be considered an error. Any other value indicates the number of logical blocks that shall be transferred. The block size shall be determined by the write parameters mode page (if in track at once, packet, or raw mode) or by the cue sheet (session at once mode).

Once actual writing to the media has started, the data stream must be uninterrupted until the recording is done. Interruptions of data are called "underruns." The underrun condition may also be forced with the "Synchronize Cache" command. The drive shall behave as follows in an underrun condition.

- 1) Session at Once mode (see Table 108 - Write Parameters Mode Page for more information)

The drive shall generate and write a lead-out (the lead-in was generated and written before any data). The drive shall update the PMA.

- 2) Track at Once mode:

The drive shall pad the track (if reserved or not minimum length) and update the PMA.

- 3) Variable Packet:

The drive shall write run-out and link blocks.

- 4) Fixed Packet:

The drive shall pad the packet.

- 5) Raw mode

The drive shall write run-out and link blocks. The drive shall read the TOC and track information from the session just written and update the PMA. It is assumed that the initiator has written the lead-out.

Note: "Update the PMA" means to update the PMA on the disc or to update the PMA Cache, which shall be written to the PMA on the disc prior to the removing the disc from the drive. PMA Caching is vendor specific.

If the block number specified by the LBA field is already written on CD-R media, the drive shall return a CHECK CONDITION status, ILLEGAL REQUEST, INVALID ADDRESS FOR WRITE. This error will indicate that an underrun may have occurred, as the run-out and link blocks occupy logical addresses. On CD-RW media, the LBA shall specify an address that is an appendable point (according to CD-R rules) or is the first user data block of an existing packet or track.

While writing is occurring, the drive may not be able to process all SCSI commands. The following is a list of commands that shall function during writing without causing a synchronize cache.

- 1) TEST UNIT READY
- 2) REQUEST SENSE
- 3) INQUIRY
- 4) READ TRACK INFO (for current track). If the LBA or track number specified is not within the current track, the drive may return CHECK CONDITION status , ILLEGAL COMMAND, Invalid Field in CDB.
- 5) READ BUFFER CAPACITY

All other commands may force a synchronize cache before executing. . This shall not be considered an error.

**Table 174 - Recommended errors for WRITE Command**

Error	Reference
Deferred Errors	Sub-clause A.1
General Errors	Table A.2
Media Access Errors	Table A.3
Write Errors	Table A.4

## Annex A Additional Sense Codes for CD (normative)

This annex lists error codes expected to be generated by CD devices. Specific commands specify that certain errors occur in response to certain conditions, but each command does not contain a comprehensive list of possible error conditions.

### A.1. Error Reporting

Any error may be reported in response to any command due to the occurrence of a deferred error. For example, a write error may occur due to a cached write command and that error shall be reported in response to the next command.

Errors listed in Table A.2 are not caused by any specific commands but by actions outside the control of the initiator.

Table A.1 lists all errors that may be generated by CD devices. Not all errors are applicable to all devices.

Table A.1 - CD Device Sense Key, ASC and ASCQ Assignments

Sense Key	ASC	ASCQ	Type	Description
0	00	00	R	NO ADDITIONAL SENSE INFORMATION
b	00	06	R	I/O PROCESS TERMINATED
5	00	11	R	AUDIO PLAY OPERATION IN PROGRESS
4	00	17	R	CLEANING REQUESTED
3	02	00	R	NO SEEK COMPLETE
2	04	00	R	LOGICAL UNIT NOT READY, CAUSE NOT REPORTABLE
2	04	01	R	LOGICAL UNIT IS IN PROCESS OF BECOMING READY
2	04	02	R	LOGICAL UNIT NOT READY, INITIALIZING CMD. REQUIRED
2	04	03	R	LOGICAL UNIT NOT READY, MANUAL INTERVENTION REQUIRED
2	04	04	++R	LOGICAL UNIT NOT READY, FORMAT IN PROGRESS
2	04	07	R	LOGICAL UNIT NOT READY, OPERATION IN PROGRESS
2	04	08	R	LOGICAL UNIT NOT READY, LONG WRITE IN PROGRESS
4	05	00	R	LOGICAL UNIT DOES NOT RESPOND TO SELECTION
3	06	00	R	NO REFERENCE POSITION FOUND
5	07	00	R	MULTIPLE PERIPHERAL DEVICES SELECTED
4	08	00	R	LOGICAL UNIT COMMUNICATION FAILURE
4	08	01	R	LOGICAL UNIT COMMUNICATION TIME-OUT
4	08	02	R	LOGICAL UNIT COMMUNICATION PARITY ERROR
4	09	00	R	TRACK FOLLOWING ERROR
4	09	01	R	TRACKING SERVO FAILURE
4	09	02	R	FOCUS SERVO FAILURE
4	09	03	R	SPINDLE SERVO FAILURE
4	09	04	R	HEAD SELECT FAULT
6	0A	00	R	ERROR LOG OVERFLOW
1	0B	00	R	WARNING
1	0B	01	R	WARNING - SPECIFIED TEMPERATURE EXCEEDED
1	0B	02	R	WARNING - ENCLOSURE DEGRADED
3	0C	00	R	WRITE ERROR
3	0C	07	R	WRITE ERROR - RECOVERY NEEDED
3	0C	08	R	WRITE ERROR - RECOVERY FAILED
3	0C	09	R	WRITE ERROR - LOSS OF STREAMING
3	0C	0A	R	WRITE ERROR - PADDING BLOCKS ADDED

All values are in hex

Table A.1 (cont.) - CD Device Sense Key, ASC and ASCQ Assignments

Sense Key	ASC	ASCQ	Type	Description
3	11	00	R	UNRECOVERED READ ERROR
3	11	01	++R	READ RETRIES EXHAUSTED
3	11	02	++R	ERROR TOO LONG TO CORRECT
3	11	05	R	L-EC UNCORRECTABLE ERROR
3	11	06	R	CIRC UNRECOVERED ERROR
3	11	0F	R	ERROR READING UPC/EAN NUMBER
3	11	10	R	ERROR READING ISRC NUMBER
b	11	11	++R	READ ERROR - LOSS OF STREAMING
3	15	00	R	RANDOM POSITIONING ERROR
3	15	01	R	MECHANICAL POSITIONING ERROR
3	15	02	R	POSITIONING ERROR DETECTED BY READ OF MEDIUM
1	17	00	R	RECOVERED DATA WITH NO ERROR CORRECTION APPLIED
1	17	01	R	RECOVERED DATA WITH RETRIES
1	17	02	R	RECOVERED DATA WITH POSITIVE HEAD OFFSET
1	17	03	R	RECOVERED DATA WITH NEGATIVE HEAD OFFSET
1	17	04	R	RECOVERED DATA WITH RETRIES AND/OR CIRC APPLIED
1	17	05	R	RECOVERED DATA USING PREVIOUS SECTOR ID
1	17	07	++R	RECOVERED DATA WITHOUT ECC - RECOMMEND REASSIGNMENT
1	17	08	++R	RECOVERED DATA WITHOUT ECC - RECOMMEND REWRITE
1	17	09	++R	RECOVERED DATA WITHOUT ECC - DATA REWRITTEN
1	18	00	R	RECOVERED DATA WITH ERROR CORRECTION APPLIED
1	18	01	R	RECOVERED DATA WITH ERROR CORR. & RETRIES APPLIED
1	18	02	R	RECOVERED DATA - DATA AUTO-REALLOCATED
1	18	03	R	RECOVERED DATA WITH CIRC
1	18	04	R	RECOVERED DATA WITH L-EC
1	18	05	R	RECOVERED DATA - RECOMMEND REASSIGNMENT
1	18	06	R	RECOVERED DATA - RECOMMEND REWRITE
5	1A	00	R	PARAMETER LIST LENGTH ERROR
4	1B	00	R	SYNCHRONOUS DATA TRANSFER ERROR
a	1D	00	++R	MISCOMPARE DURING VERIFY OPERATION
5	20	00	R	INVALID COMMAND OPERATION CODE
5	21	00	R	LOGICAL BLOCK ADDRESS OUT OF RANGE
5	21	01	R	INVALID ELEMENT ADDRESS
5	24	00	R	INVALID FIELD IN CDB
5	25	00	R	LOGICAL UNIT NOT SUPPORTED

All values are in hex

Table A.1 (cont.) - CD Device Sense Key, ASC and ASCQ Assignments

Sense Key	ASC	ASCQ	Type	Description
5	26	00	R	INVALID FIELD IN PARAMETER LIST
5	26	01	R	PARAMETER NOT SUPPORTED
5	26	02	R	PARAMETER VALUE INVALID
5	26	03	R	THRESHOLD PARAMETERS NOT SUPPORTED
5	26	04	R	INVALID RELEASE OF ACTIVE PERSISTENT RESERVATION
5	27	00	++R	WRITE PROTECTED
5	27	01	++R	HARDWARE WRITE PROTECTED
5	27	02	++R	LOGICAL UNIT SOFTWARE WRITE PROTECTED
5	27	03	++R	ASSOCIATED WRITE PROTECT
5	27	04	++R	PERSISTENT WRITE PROTECT
5	27	05	++R	PERMANENT WRITE PROTECT
6	28	00	R	NOT READY TO READY CHANGE, MEDIUM MAY HAVE CHANGED
6	28	01	R	IMPORT OR EXPORT ELEMENT ACCESSED
6	29	00	R	POWER ON, RESET, OR BUS DEVICE RESET OCCURRED
6	29	01	R	POWER ON OCCURRED
6	29	02	R	SCSI BUS RESET OCCURRED
6	29	03	R	BUS DEVICE RESET FUNCTION OCCURRED
6	29	04	R	DEVICE INTERNAL RESET
6	2A	00	R	PARAMETERS CHANGED
6	2A	01	R	MODE PARAMETERS CHANGED
6	2A	02	R	LOG PARAMETERS CHANGED
6	2A	03	R	RESERVATIONS PREEMPTED
5	2B	00	R	COPY CANNOT EXECUTE SINCE HOST CANNOT DISCONNECT
5	2C	00	R	COMMAND SEQUENCE ERROR
5	2C	03	R	CURRENT PROGRAM AREA IS NOT EMPTY
5	2C	04	R	CURRENT PROGRAM AREA IS EMPTY
6	2F	00	R	COMMANDS CLEARED BY ANOTHER INITIATOR
2	30	00	R	INCOMPATIBLE MEDIUM INSTALLED
2	30	01	R	CANNOT READ MEDIUM - UNKNOWN FORMAT
2	30	02	R	CANNOT READ MEDIUM - INCOMPATIBLE FORMAT
2	30	03	++R	CLEANING CARTRIDGE INSTALLED
2	30	04	R	CANNOT WRITE MEDIUM - UNKNOWN FORMAT
2	30	05	R	CANNOT WRITE MEDIUM - INCOMPATIBLE FORMAT
2	30	06	++R	CANNOT FORMAT MEDIUM - INCOMPATIBLE MEDIUM
2	30	07	R	CLEANING FAILURE
5	30	08	R	CANNOT WRITE - APPLICATION CODE MISMATCH
5	30	09	R	CURRENT SESSION NOT FIXATED FOR APPEND

All values are in hex

Table A.1 (cont.) - CD Device Sense Key, ASC and ASCQ Assignments

Sense Key	ASC	ASCQ	Type	Description
3	31	00	R	MEDIUM FORMAT CORRUPTED
3	31	01	R	FORMAT COMMAND FAILED
	34	00	R	ENCLOSURE FAILURE
	35	00	R	ENCLOSURE SERVICES FAILURE
	35	01	R	UNSUPPORTED ENCLOSURE FUNCTION
	35	02	R	ENCLOSURE SERVICES UNAVAILABLE
	35	03	R	ENCLOSURE SERVICES TRANSFER FAILURE
	35	04	R	ENCLOSURE SERVICES TRANSFER REFUSED
1	37	00	R	ROUNDED PARAMETER
5	39	00	R	SAVING PARAMETERS NOT SUPPORTED
2	3A	00	R	MEDIUM NOT PRESENT
2	3A	01	++R	MEDIUM NOT PRESENT - TRAY CLOSED
2	3A	02	++R	MEDIUM NOT PRESENT - TRAY OPEN
6	3B	0D	R	MEDIUM DESTINATION ELEMENT FULL
6	3B	0E	R	MEDIUM SOURCE ELEMENT EMPTY
6	3B	0F	R	END OF MEDIUM REACHED
6	3B	11	R	MEDIUM MAGAZINE NOT ACCESSIBLE
6	3B	12	R	MEDIUM MAGAZINE REMOVED
6	3B	13	R	MEDIUM MAGAZINE INSERTED
6	3B	14	R	MEDIUM MAGAZINE LOCKED
6	3B	15	R	MEDIUM MAGAZINE UNLOCKED
5	3D	00	R	INVALID BITS IN IDENTIFY MESSAGE
2	3E	00	R	LOGICAL UNIT HAS NOT SELF-CONFIGURED YET
4	3E	01	++R	LOGICAL UNIT FAILURE
4	3E	02	++R	TIMEOUT ON LOGICAL UNIT
6	3F	00	R	TARGET OPERATING CONDITIONS HAVE CHANGED
6	3F	01	R	MICROCODE HAS BEEN CHANGED
6	3F	02	R	CHANGED OPERATING DEFINITION
6	3F	03	R	INQUIRY DATA HAS CHANGED
4	40	NN	R	DIAGNOSTIC FAILURE ON COMPONENT NN (80H-FFH)
5	43	00	R	MESSAGE ERROR
4	44	00	R	INTERNAL TARGET FAILURE
b	45	00	R	SELECT OR RESELECT FAILURE
4	46	00	R	UNSUCCESSFUL SOFT RESET
4	47	00	R	SCSI PARITY ERROR
b	48	00	R	INITIATOR DETECTED ERROR MESSAGE RECEIVED
b	49	00	R	INVALID MESSAGE ERROR

All values are in hex



Table A.1 (cont.) - CD Device Sense Key, ASC and ASCQ Assignments

Sense Key	ASC	ASCQ	Type	Description
4	4A	00	R	COMMAND PHASE ERROR
4	4B	00	R	DATA PHASE ERROR
4	4C	00	R	LOGICAL UNIT FAILED SELF-CONFIGURATION
b	4D	NN	R	TAGGED OVERLAPPED COMMANDS (NN = QUEUE TAG)
b	4E	00	R	OVERLAPPED COMMANDS ATTEMPTED
3	51	00	++R	ERASE FAILURE
4	53	00	R	MEDIA LOAD OR EJECT FAILED
5	53	02	R	MEDIUM REMOVAL PREVENTED
3	57	00	R	UNABLE TO RECOVER TABLE-OF-CONTENTS
6	5A	00	R	OPERATOR REQUEST OR STATE CHANGE INPUT
6	5A	01	R	OPERATOR MEDIUM REMOVAL REQUEST
6	5A	02	++R	OPERATOR SELECTED WRITE PROTECT
6	5A	03	++R	OPERATOR SELECTED WRITE PERMIT
6	5B	00	R	LOG EXCEPTION
6	5B	01	R	THRESHOLD CONDITION MET
6	5B	02	R	LOG COUNTER AT MAXIMUM
6	5B	03	R	LOG LIST CODES EXHAUSTED
6	5D	00	R	FAILURE PREDICTION THRESHOLD EXCEEDED
6	5D	FF	R	FAILURE PREDICTION THRESHOLD EXCEEDED (FALSE)
6	5E	00	R	LOW POWER CONDITION ON
6	5E	01	R	IDLE CONDITION ACTIVATED BY TIMER
6	5E	02	R	STANDBY CONDITION ACTIVATED BY TIMER
6	5E	03	R	IDLE CONDITION ACTIVATED BY COMMAND
6	5E	04	R	STANDBY CONDITION ACTIVATED BY COMMAND
5	63	00	R	END OF USER AREA ENCOUNTERED ON THIS TRACK
5	63	01	R	PACKET DOES NOT FIT IN AVAILABLE SPACE
5	64	00	R	ILLEGAL MODE FOR THIS TRACK
5	64	01	R	INVALID PACKET SIZE
4	65	00	R	VOLTAGE FAULT

All values are in hex

Table A.1 (cont.) - CD Device Sense Key, ASC and ASCQ Assignments

Sense Key	ASC	ASCQ	Type	Description
3	72	00	R	SESSION FIXATION ERROR
3	72	01	R	SESSION FIXATION ERROR WRITING LEAD-IN
3	72	02	R	SESSION FIXATION ERROR WRITING LEAD-OUT
5	72	03	R	SESSION FIXATION ERROR - INCOMPLETE TRACK IN SESSION
5	72	04	R	EMPTY OR PARTIALLY WRITTEN RESERVED TRACK
3	73	00	R	CD CONTROL ERROR
1	73	01	R	POWER CALIBRATION AREA ALMOST FULL
3	73	02	R	POWER CALIBRATION AREA IS FULL
3	73	03	R	POWER CALIBRATION AREA ERROR
3	73	04	R	PROGRAM MEMORY AREA UPDATE FAILURE
3	73	05	R	PROGRAM MEMORY AREA IS FULL

All values are in hex

Table A.2 lists errors that may occur at any time, typically in response to a protocol or hardware error or user intervention.

Table A.2 - CD General Errors

Sense Key	ASC	ASCQ		Description
0	00	00	R	NO ADDITIONAL SENSE INFORMATION
b	00	06	R	I/O PROCESS TERMINATED
2	04	00	R	LOGICAL UNIT NOT READY, CAUSE NOT REPORTABLE
2	04	01	R	LOGICAL UNIT IS IN PROCESS OF BECOMING READY
2	04	02	R	LOGICAL UNIT NOT READY, INITIALIZING CMD. REQUIRED
2	04	03	R	LOGICAL UNIT NOT READY, MANUAL INTERVENTION REQUIRED
2	04	04	++R	LOGICAL UNIT NOT READY, FORMAT IN PROGRESS
2	04	07	R	LOGICAL UNIT NOT READY, OPERATION IN PROGRESS
2	04	08	R	LOGICAL UNIT NOT READY, LONG WRITE IN PROGRESS
4	05	00	R	LOGICAL UNIT DOES NOT RESPOND TO SELECTION
5	07	00	R	MULTIPLE PERIPHERAL DEVICES SELECTED
4	08	00	R	LOGICAL UNIT COMMUNICATION FAILURE
4	08	01	R	LOGICAL UNIT COMMUNICATION TIME-OUT
4	08	02	R	LOGICAL UNIT COMMUNICATION PARITY ERROR
6	0A	00	R	ERROR LOG OVERFLOW
1	0B	00	R	WARNING
1	0B	01	R	WARNING - SPECIFIED TEMPERATURE EXCEEDED
1	0B	02	R	WARNING - ENCLOSURE DEGRADED
5	1A	00	R	PARAMETER LIST LENGTH ERROR
4	1B	00	R	SYNCHRONOUS DATA TRANSFER ERROR
5	20	00	R	INVALID COMMAND OPERATION CODE
5	24	00	R	INVALID FIELD IN CDB
5	25	00	R	LOGICAL UNIT NOT SUPPORTED
5	26	00	R	INVALID FIELD IN PARAMETER LIST
5	26	01	R	PARAMETER NOT SUPPORTED
5	26	02	R	PARAMETER VALUE INVALID
6	28	00	R	NOT READY TO READY CHANGE, MEDIUM MAY HAVE CHANGED
6	29	00	R	POWER ON, RESET, OR BUS DEVICE RESET OCCURRED
6	29	01	R	POWER ON OCCURRED
6	29	02	R	SCSI BUS RESET OCCURRED
6	29	03	R	BUS DEVICE RESET FUNCTION OCCURRED
6	29	04	R	DEVICE INTERNAL RESET
6	2A	00	R	PARAMETERS CHANGED
6	2A	01	R	MODE PARAMETERS CHANGED
6	2A	02	R	LOG PARAMETERS CHANGED
6	2F	00	R	COMMANDS CLEARED BY ANOTHER INITIATOR

All values are in hex

Table A.2 (cont.) - CD General Errors

Sense Key	ASC	ASCQ		Description
	34	00	R	ENCLOSURE FAILURE
	35	00	R	ENCLOSURE SERVICES FAILURE
	35	01	R	UNSUPPORTED ENCLOSURE FUNCTION
	35	02	R	ENCLOSURE SERVICES UNAVAILABLE
	35	03	R	ENCLOSURE SERVICES TRANSFER FAILURE
	35	04	R	ENCLOSURE SERVICES TRANSFER REFUSED
5	3D	00	R	INVALID BITS IN IDENTIFY MESSAGE
2	3E	00	R	LOGICAL UNIT HAS NOT SELF-CONFIGURED YET
4	3E	01	++R	LOGICAL UNIT FAILURE
4	3E	02	++R	TIMEOUT ON LOGICAL UNIT
6	3F	00	R	TARGET OPERATING CONDITIONS HAVE CHANGED
6	3F	01	R	MICROCODE HAS BEEN CHANGED
6	3F	02	R	CHANGED OPERATING DEFINITION
6	3F	03	R	INQUIRY DATA HAS CHANGED
4	40	NN	R	DIAGNOSTIC FAILURE ON COMPONENT NN (80H-FFH)
5	43	00	R	MESSAGE ERROR
4	44	00	R	INTERNAL TARGET FAILURE
b	45	00	R	SELECT OR RESELECT FAILURE
4	46	00	R	UNSUCCESSFUL SOFT RESET
4	47	00	R	SCSI PARITY ERROR
b	48	00	R	INITIATOR DETECTED ERROR MESSAGE RECEIVED
b	49	00	R	INVALID MESSAGE ERROR
4	4A	00	R	COMMAND PHASE ERROR
4	4B	00	R	DATA PHASE ERROR
4	4C	00	R	LOGICAL UNIT FAILED SELF-CONFIGURATION
b	4D	NN	R	TAGGED OVERLAPPED COMMANDS (NN = QUEUE TAG)
b	4E	00	R	OVERLAPPED COMMANDS ATTEMPTED
6	5A	00	R	OPERATOR REQUEST OR STATE CHANGE INPUT
6	5A	01	R	OPERATOR MEDIUM REMOVAL REQUEST
6	5B	00	R	LOG EXCEPTION
6	5B	01	R	THRESHOLD CONDITION MET
6	5B	02	R	LOG COUNTER AT MAXIMUM
6	5B	03	R	LOG LIST CODES EXHAUSTED
6	5D	00	R	FAILURE PREDICTION THRESHOLD EXCEEDED
6	5D	FF	R	FAILURE PREDICTION THRESHOLD EXCEEDED (FALSE)
4	65	00	R	VOLTAGE FAULT

Note: All values are in hex

Table A.3 lists errors that may be generated by media access commands of any type (read of control or user data or writing of control or data area).

Table A.3 - CD Media Access Errors

Sense Key	ASC	ASCQ		Description
4	00	17	R	CLEANING REQUESTED
3	02	00	R	NO SEEK COMPLETE
3	06	00	R	NO REFERENCE POSITION FOUND
4	09	00	R	TRACK FOLLOWING ERROR
4	09	01	R	TRACKING SERVO FAILURE
4	09	02	R	FOCUS SERVO FAILURE
4	09	03	R	SPINDLE SERVO FAILURE
4	09	04	R	HEAD SELECT FAULT
3	11	00	R	UNRECOVERED READ ERROR
3	11	01	++R	READ RETRIES EXHAUSTED
3	11	02	++R	ERROR TOO LONG TO CORRECT
3	11	05	R	L-EC UNCORRECTABLE ERROR
3	11	06	R	CIRC UNRECOVERED ERROR
3	11	0F	R	ERROR READING UPC/EAN NUMBER
3	11	10	R	ERROR READING ISRC NUMBER
3	15	00	R	RANDOM POSITIONING ERROR
3	15	01	R	MECHANICAL POSITIONING ERROR
3	15	02	R	POSITIONING ERROR DETECTED BY READ OF MEDIUM
1	17	00	R	RECOVERED DATA WITH NO ERROR CORRECTION APPLIED
1	17	01	R	RECOVERED DATA WITH RETRIES
1	17	02	R	RECOVERED DATA WITH POSITIVE HEAD OFFSET
1	17	03	R	RECOVERED DATA WITH NEGATIVE HEAD OFFSET
1	17	04	R	RECOVERED DATA WITH RETRIES AND/OR CIRC APPLIED
1	17	05	R	RECOVERED DATA USING PREVIOUS SECTOR ID
1	17	07	++R	RECOVERED DATA WITHOUT ECC - RECOMMEND REASSIGNMENT
1	17	08	++R	RECOVERED DATA WITHOUT ECC - RECOMMEND REWRITE
1	17	09	++R	RECOVERED DATA WITHOUT ECC - DATA REWRITTEN
1	18	00	R	RECOVERED DATA WITH ERROR CORRECTION APPLIED
1	18	01	R	RECOVERED DATA WITH ERROR CORR. & RETRIES APPLIED
1	18	02	R	RECOVERED DATA - DATA AUTO-REALLOCATED
1	18	03	R	RECOVERED DATA WITH CIRC
1	18	04	R	RECOVERED DATA WITH L-EC
1	18	05	R	RECOVERED DATA - RECOMMEND REASSIGNMENT
1	18	06	R	RECOVERED DATA - RECOMMEND REWRITE
5	21	00	R	LOGICAL BLOCK ADDRESS OUT OF RANGE

Note: All values are in hex

Table A.3 (cont.) - CD Media Access Errors

Sense Key	ASC	ASCQ		Description
2	30	00	R	INCOMPATIBLE MEDIUM INSTALLED
2	30	01	R	CANNOT READ MEDIUM - UNKNOWN FORMAT
2	30	02	R	CANNOT READ MEDIUM - INCOMPATIBLE FORMAT
2	30	03	++R	CLEANING CARTRIDGE INSTALLED
2	30	07	R	CLEANING FAILURE
3	31	00	R	MEDIUM FORMAT CORRUPTED
2	3A	00	R	MEDIUM NOT PRESENT
2	3A	01	++R	MEDIUM NOT PRESENT - TRAY CLOSED
2	3A	02	++R	MEDIUM NOT PRESENT - TRAY OPEN
3	57	00	R	UNABLE TO RECOVER TABLE-OF-CONTENTS
6	5E	00	R	LOW POWER CONDITION ON
6	5E	01	R	IDLE CONDITION ACTIVATED BY TIMER
6	5E	02	R	STANDBY CONDITION ACTIVATED BY TIMER
6	5E	03	R	IDLE CONDITION ACTIVATED BY COMMAND
6	5E	04	R	STANDBY CONDITION ACTIVATED BY COMMAND
5	63	00	R	END OF USER AREA ENCOUNTERED ON THIS TRACK
5	64	00	R	ILLEGAL MODE FOR THIS TRACK
3	73	00	R	CD CONTROL ERROR

Note: All values are in hex

Table A.4 describes errors that may be generated by commands that cause user or control data to be written to the medium.

**Table A.4 - CD Write Errors**

Sense Key	ASC	ASCQ		Description
3	0C	00	R	WRITE ERROR
3	0C	07	R	WRITE ERROR - RECOVERY NEEDED
3	0C	08	R	WRITE ERROR - RECOVERY FAILED
3	0C	09	R	WRITE ERROR - LOSS OF STREAMING
3	0C	0A	R	WRITE ERROR - PADDING BLOCKS ADDED
5	27	00	++R	WRITE PROTECTED
5	27	01	++R	HARDWARE WRITE PROTECTED
5	27	02	++R	LOGICAL UNIT SOFTWARE WRITE PROTECTED
5	27	03	++R	ASSOCIATED WRITE PROTECT
5	27	04	++R	PERSISTENT WRITE PROTECT
5	27	05	++R	PERMANENT WRITE PROTECT
2	30	04	R	CANNOT WRITE MEDIUM - UNKNOWN FORMAT
2	30	05	R	CANNOT WRITE MEDIUM - INCOMPATIBLE FORMAT
5	30	08	R	CANNOT WRITE - APPLICATION CODE MISMATCH
5	30	09	R	CURRENT SESSION NOT FIXATED FOR APPEND
6	5A	02	++R	OPERATOR SELECTED WRITE PROTECT
6	5A	03	++R	OPERATOR SELECTED WRITE PERMIT
1	73	01	R	POWER CALIBRATION AREA ALMOST FULL
3	73	02	R	POWER CALIBRATION AREA IS FULL
3	73	03	R	POWER CALIBRATION AREA ERROR
3	73	04	R	PROGRAM MEMORY AREA UPDATE FAILURE
3	73	05	R	PROGRAM MEMORY AREA IS FULL

Note: All values are in hex

Table A.5 describes errors that may be generated by commands that cause the CD session to be closed.

**Table A.5 - CD Fixation Errors**

Sense Key	ASC	ASCQ		Description
5	2C	03	R	CURRENT PROGRAM AREA IS NOT EMPTY
5	2C	04	R	CURRENT PROGRAM AREA IS EMPTY
3	72	00	R	SESSION FIXATION ERROR
3	72	01	R	SESSION FIXATION ERROR WRITING LEAD-IN
3	72	02	R	SESSION FIXATION ERROR WRITING LEAD-OUT
5	72	03	R	SESSION FIXATION ERROR - INCOMPLETE TRACK IN SESSION
5	72	04	R	EMPTY OR PARTIALLY WRITTEN RESERVED TRACK

Note: All values are in hex

## Annex B ATAPI Compliance (normative)

### B.1. Introduction

This section describes the implementation of the MultiMedia Commands in ATAPI devices. The intent is to make the command sets highly compatible. It is desired that a common driver may be written to control both SCSI and ATAPI devices.

### B.2. General

ATAPI devices implement a subset of SCSI behavior. Certain errors and conditions that exist in SCSI don't exist in ATAPI. In addition, certain terms are used in ATAPI instead of related SCSI terms. The mechanisms for transporting the commands, data, and status are unique to each transport. Addressing of units is also unique to each transport. MMC does not directly specify any of these mechanisms; the command and data layer definition may be layered on either transport.

#### B.2.1. Terms

B.2.1.1. Host - the ATAPI equivalent for the SCSI term "Initiator."

B.2.1.2. Device - the ATAPI equivalent for the SCSI term "Target" or "Logical Unit."

B.2.1.3. Command Packet - the ATAPI equivalent for the SCSI term "Command Descriptor Block."

#### B.2.2. Supported Block Sizes

ATAPI does not use the block size in the mode select block descriptor. Instead, the block size shall be determined by the command. The READ command shall return 2048 bytes per block. The WRITE command shall send the number of bytes per block as determined by the WRITE PARAMETERS mode page. The READ CD and READ CD MSF commands shall return the number of bytes per block as specified by the command.

#### B.2.3. CD Audio error reporting

PLAY commands with the immediate bit set in the audio control mode return status as soon as the command has been validated (which may involve a seek to the starting address). The playback operation continues and may complete without notification to the initiator. Error termination of audio operations shall not be reported to the host by returning immediate CHECK CONDITION status to the next command. The status may be obtained with READ SUB-CHANNEL or any command that returns the audio status.

#### B.2.4. Multi-Initiator Environment

A multi-initiator environment cannot exist in ATAPI. Therefore, conditions that occur only in multi-initiator environments cannot occur. For example, there is no way in ATAPI to produce a reservation conflict, or for another initiator to change common mode parameters. The descriptions of these conditions in SCSI shall be ignored in ATAPI implementations.

#### B.2.5. Command Packet Padding

All ATAPI commands are twelve bytes long. SCSI commands are six, ten, or twelve bytes long. To build the appropriate ATAPI Command Packet, padding bytes shall be added to the six and ten byte SCSI Command Descriptor Blocks. Six byte commands shall have six padding bytes added. Ten byte commands shall have two padding bytes added. These pad bytes shall have a value of zero.

The Control byte shall be reserved and set to zero.



### B.3. ATAPI CD Commands

Commands for ATAPI CD devices are listed in Table B.1. Commands that have no differences other than those mentioned in sub-clauses B.2.1. through B.2.5. are documented only in the main body of the document.

Table B.1. - ATAPI CD Commands

Command Name	Operation Code	Type	Sub-clause
Blank	A1h	E	MMC
Close Track/Session	5Bh	R	MMC
Format Unit	04h	E	MMC
Inquiry	12h	M	SPC
Load/Unload CD	A6h	C	MMC
Mechanism Status	BDh	M	MMC
Mode Select (10)	55h	M	SPC
Mode Sense (10)	5Ah	M	SPC
Pause/Resume	4Bh	A	MMC
Play Audio (10)	45h	A	MMC
Play Audio (12)	A5h	A	MMC
Play Audio MSF	47h	A	MMC
Play CD	BCh	O	MMC
Prevent/Allow Medium Removal	1Eh	M	SPC
Read (10)	28h	M	SBC
Read (12)	A8h	M	SBC
Read Buffer Capacity	5Ch	O	MMC
Read CD	BEh	M	MMC
Read CD MSF	B9h	M	MMC 5.1.9.
Read CD Recorded Capacity	25h	M	MMC 5.1.10.
Read Disc Information	51h	R	MMC 6.2.6.
Read Header	44h	M	MMC 5.1.11.
Read Master Cue	59h	O	MMC 6.2.7.
Read Sub-channel	42h	M	MMC 5.1.12.
Read TOC/PMA/ATIP	43h	M	MMC 5.1.13.
Read Track Information	52h	R	MMC 6.2.8.

Key: M = command implementation is mandatory  
 O = command implementation is optional  
 A = mandatory command when implementing Audio  
 R = mandatory command for CD-R/RW devices  
 E = mandatory command for CD-RW devices  
 C = mandatory for embedded changer

Table B.1. (cont.) - ATAPI CD Commands

Command Name	Operation Code	Type	Sub-clause
Repair Track	58h	O	MMC 6.2.9.
Request Sense	03h	M	SPC
Reserve Track	53h	R	MMC 6.2.10.
Scan	BAh	A	MMC 5.1.14.
Seek	2Bh	M	SBC
Send Cue Sheet	5Dh	O	MMC 6.2.11.
Send OPC Information	54h	O	MMC 6.2.12.
Set CD Speed	BBh	R	MMC 5.1.15.
Start/Stop Unit	1Bh	M	SBC
Stop Play/Scan	4Eh	M	MMC 5.1.16.
Synchronize Cache	35h	R	MMC 6.2.13.
Test Unit Ready	00h	M	SPC
Write (10)	2Ah	R	SBC
Write (12)	AAh	R	SBC

Key: M = command implementation is mandatory  
O = command implementation is optional  
A = mandatory command when implementing Audio  
R = mandatory command for CD-R/RW devices  
E = mandatory command for CD-RW devices  
C = mandatory for embedded changer

## B.4. Parameters for CD devices

### B.4.1. Mode parameters

This sub-clause defines the descriptors and pages for mode parameters used with CD devices.

The Mode Parameter Block Descriptor does not apply to ATAPI devices, and the Block Descriptor Length in the Mode Parameter Header shall be set to 0. As the Block Descriptor doesn't apply, no density code shall apply.

The mode page codes for ATAPI CD devices are defined in Table B.2.

Table B.2 - Mode page codes

Page code	description	ref. doc.
00h	Vendor specific (does not require page format)	
01h	Read error recovery page	
02h	Write Cache Page	
03h-04h	Reserved	
05h	Write Parameter Page	
06h	Reserved	
07h	Reserved	
08h	Reserved	
09h	Reserved	
0Ah	Reserved	
0Bh	Reserved	
0Ch	Reserved	
0Dh	CD page	
0Eh	CD audio control page	
0Fh - 1Fh	Reserved	
20h - 29h	Vendor specific (page format required)	
2Ah	CD Capabilities and Mechanism Status Page	
2Bh - 3Eh	Vendor specific (page format required)	
3Fh	Return all pages (valid only for mode sense command)	

### B.4.2. CD Audio Control parameters

All parameters are the same as defined for SCSI devices, except that the IMMED bit shall be set to 1.

### B.4.3. Write Parameters Mode Page

In the Write Parameters Mode Page, (Write Type field) support for Packet and Track at Once shall be mandatory. Session at Once and Raw are optional.

## Annex C Command Play/Scan Operation (normative)

The CD-ROM device should accept and perform the commands specified in Table C.1 without terminating an Audio Play command already in progress.

**Table C.1 - Commands That Will Stop a Play or Scan Operation**

Opcode	Command Description	Action Taken
ANY	When it generates an Illegal Field in Command Packet Check Condition	Will terminate normally
00h	TEST UNIT READY	Will execute normally
03h	REQUEST SENSE	Will execute normally
12h	INQUIRY	The data will be returned
1Bh	START/STOP UNIT	Will terminate immediately
1Eh	PREVENT/ALLOW MEDIA REMOVAL	Will terminate normally
25h	READ CD RECORDED CAPACITY	Will terminate normally
28h	READ (10)	Will terminate immediately
2Bh	SEEK	Will terminate immediately
42h	READ SUB-CHANNEL	Only the current position information (Format Code 01h) will be supported while the play is in progress. If any other type of information is requested the READ SUB-CHANNEL will not be executed and a CHECK CONDITION will be generated.
43h	READ TOC/PMA/ATIP	Only drives that cache the TOC will be able to respond to this command while the play is in progress. If the drive does not support caching the TOC, the command will not be executed and a CHECK CONDITION will be generated.
44h	READ HEADER	Will terminate immediately
45h	PLAY AUDIO (10)	Will terminate immediately
47h	PLAY AUDIO MSF	Will terminate immediately
4Bh	PAUSE/RESUME	Will terminate immediately
55h	MODE SELECT	The Mode Select will be accepted and executed as long as no Media or Mode information is changed. If parameters that affect the play are changed, the Mode Select will terminate with a CHECK CONDITION without being executed
5Ah	MODE SENSE	Will terminate normally
A6h	LOAD/UNLOAD CD	Will terminate immediately
B4h	PLAY CD	Will terminate immediately
BDh	MECHANISM STATUS	Will execute normally
BEh	READ CD	Will terminate immediately
B9h	READ CD MSF	Will terminate immediately
BAh	SCAN	SCAN command will be executed and the PLAY command will resume at completion of the scan
BBh	SET CD SPEED	Will terminate immediately

## Annex N Command Listings (Informative)

Table N.1 - Multimedia Commands - Alphabetically

Command Name	Operation Code	MMC Type	Sub-clause
BLANK Command	A1h	O	6.2.2.
CLOSE TRACK/SESSION	5Bh	M	6.2.3.
FORMAT UNIT	04h	O	6.2.4.
LOAD/UNLOAD CD	A6h	O	5.1.1.
MECHANISM STATUS	BDh	M	5.1.2.
PAUSE/RESUME	4Bh	O	5.1.3.
PLAY AUDIO (10)	45h	A	5.1.4.
PLAY AUDIO (12)	A5h	A	5.1.5.
PLAY AUDIO MSF	47h	A	5.1.6.
READ BUFFER CAPACITY	5Ch	O	6.2.5.
READ CD	BEh	O	5.1.8.
READ CD MSF	B9h	M	5.1.9.
READ CD RECORDED CAPACITY	25h	M	5.1.10.
READ DISC INFORMATION	51h	M	6.2.6.
READ HEADER	44h	M	5.1.11.
READ MASTER CUE	59h	O	6.2.7.
READ SUB-CHANNEL	42h	M	5.1.12.
READ TOC/PMA/ATIP	43h	M	5.1.13.
READ TRACK INFORMATION	52h	O	6.2.8.
REPAIR TRACK	58h	O	6.2.9.
RESERVE TRACK	53h	M	6.2.10.
SCAN	BAh	O	5.1.14.
SEEK	2Bh	M	
SEND CUE SHEET	5Dh	O	6.2.11.
SEND OPC INFORMATION	54h	O	6.2.12.
SET CD SPEED	BBh	M	5.1.15.
STOP PLAY/SCAN	4Eh	O	5.1.16.
SYNCHRONIZE CACHE	35h	M	6.2.13.
WRITE (10)	2Ah	O	6.2.14.

Key: M = command implementation is mandatory  
O = command implementation is optional  
A = Must be implemented for Audio

Table N.2 - Multimedia Commands - by OpCode

Command Name	Operation Code	MMC Type	Sub-clause
FORMAT UNIT	04h	O	6.2.4.
READ CD RECORDED CAPACITY	25h	M	5.1.10.
WRITE (10)	2Ah	O	6.2.14.
SEEK	2Bh	O	
SYNCHRONIZE CACHE(FLUSH)	35h	M	6.2.13.
READ SUB-CHANNEL	42h	M	5.1.12.
READ TOC/PMA/ATIP	43h	M	5.1.13.
READ HEADER	44h	M	5.1.11.
PLAY AUDIO (10)	45h	A	5.1.4.
PLAY AUDIO MSF	47h	A	5.1.4.
PAUSE/RESUME	4Bh	O	5.1.3.
STOP PLAY/SCAN	4Eh	O	5.1.16.
READ DISC INFORMATION	51h	M	6.2.6.
READ TRACK INFORMATION	52h	O	6.2.8.
RESERVE TRACK	53h	M	6.2.10
SEND OPC INFORMATION	54h	O	6.2.12.
REPAIR TRACK	58h	O	6.2.9.
READ MASTER CUE	59h	O	6.2.7.
CLOSE TRACK/SESSION	5Bh	M	6.2.3.
READ BUFFER CAPACITY	5Ch	O	6.2.5.
BLANK	A1h	O	6.2.2
PLAY AUDIO (12)	A5h	A	5.1.5.
LOAD/UNLOAD CD	A6h	O	5.1.1.
READ CD MSF	B9h	M	5.1.9.
SCAN	BAh	O	5.1.14.
SET CD SPEED	BBh	M	5.1.15.
MECHANISM STATUS	BDh	M	5.1.2.
READ CD	BEh	O	5.1.8.

Key: M = command implementation is mandatory  
O = command implementation is optional  
A = Must be implemented for Audio

Table N.3 - Commands Common to all SCSI Devices

Command Name	Operation Code	SCSI-3	
		Type	Ref Std
CHANGE DEFINITION	40h	O	
COMPARE	39h	O	
COPY	18h	O	
COPY AND VERIFY	3Ah	O	
INQUIRY	12h	M	
LOCK/UNLOCK CACHE	36h	O	
LOG SELECT	4Ch	O	
LOG SENSE	4Dh	O	
MODE SELECT (10)	55h	O	
MODE SELECT (6)	15h	M	
MODE SENSE (10)	5Ah	M	
MODE SENSE (6)	1Ah	M	
PREFETCH	34h	O	
PREVENT/ALLOW MEDIUM REMOVAL	1Eh	M	
READ (10)	28h	M	
READ (12)	A8h	O	
READ (6)	08h	O	
READ BUFFER	3Ch	O	
READ LONG	3Eh	O	
RECEIVE DIAGNOSTIC RESULTS	1Ch	O	
RELEASE (10)	57h	M	
RELEASE(6)	17h	O	
REQUEST SENSE	03h	M	
RESERVE(10)	56h	M	
RESERVE(6)	16h	O	
SEEK (10)	2Bh	M	
SEEK (6)	0Bh	M	
SEND DIAGNOSTIC	1Dh	M	
SET LIMITS (10)	33h	O	
SET LIMITS (12)	B3h	O	
START/STOP UNIT	1Bh	M	

Key: M = command implementation is mandatory  
O = command implementation is optional

Table N.4 (cont.) - Commands Common to all SCSI Devices

Command Name	Operation Code	SCSI-3	
		Type	Ref Std
TEST UNIT READY	00h	M	
VERIFY (10)	2Fh	O	
VERIFY (12)	AFh	O	
WRITE BUFFER	3Bh	O	

Key: M = command implementation is mandatory  
O = command implementation is optional

The following command codes are vendor-specific: 02h, 05h, 06h, 09h, 0Ch, 0Dh, 0Eh, 0Fh, 10h, 11h, 13h, 14h, 19h, 20h, 21h, 22h, 23h, 24h, 26h, 27h, 29h, and C0h through FFh.



## Annex O - Functional Requirements for CD-R (Informative)

### O.1. - INTRODUCTION

With the proliferation of CDs in the marketplace, backward compatibility was a major goal of the MMC document. The existing commands within ATAPI and SCSI-3 were reviewed and those commands deemed appropriate were incorporated into the MMC document.

In the generation of a CD, the industry has elected to follow a proprietary specification referred to as the "Orange Book." This specification is obtained by applying for a license. Where possible, this standard attempted to follow the architectural flow identified in the "Orange Book."

#### O.1.1. - GENERAL

The initiator assumes no prior knowledge of the target and will interrogate the target to determine the attributes of the target. The initiator uses the attributes and issues commands to the target, the target responds with status.

This annex contains architectural models and flow diagrams that will provide guidance in the development of commands. These requirements are identified in order to resolve any conflicts in the architectural differences of any proposals presented.

### O.2. - Disc Definition

A disc contains sessions. Each session contains a lead-in, program area, and lead-out. The program area contains tracks. Each track may contain a pre-gap, user data area, and post-gap. The user data area may contain packets.

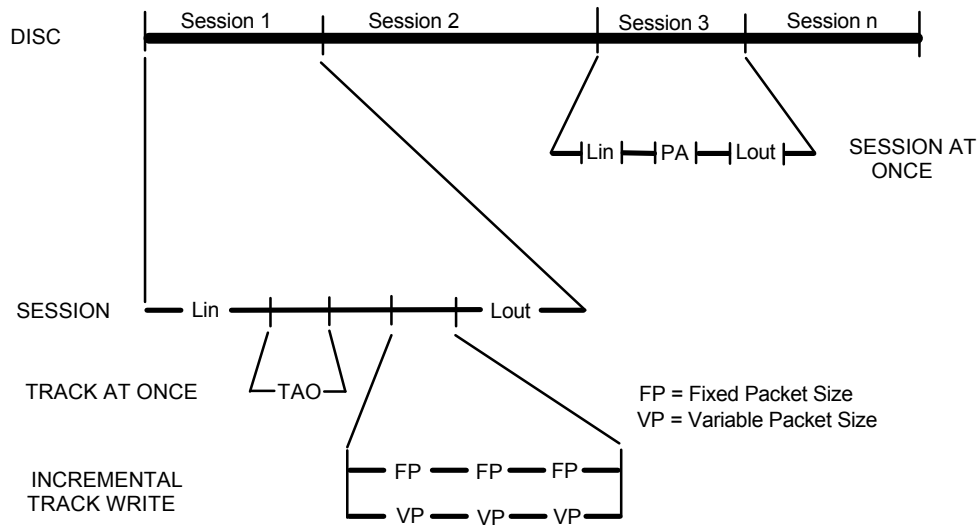

Figure O.1 - Disc Area Definitions

O.3. - Status Definitions

O.3.1. - Track Definitions

O.3.1.1. - Static track definitions



Note F1: The recorded PMA is identical for these three states.

O.3.1.2. - Dynamic Track definitions

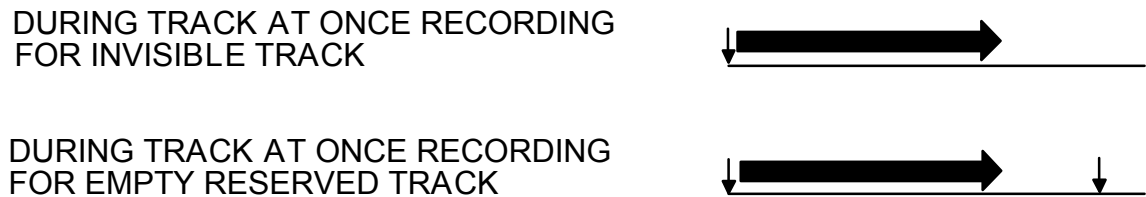

O.3.2. - Session Definitions

O.3.2.1. - Static Session definition

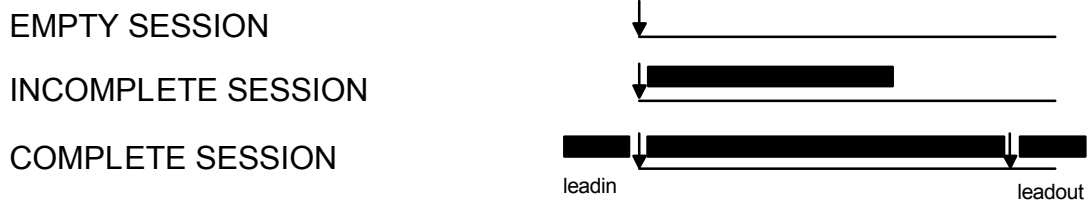

O.3.2.2. - Session State Transitions

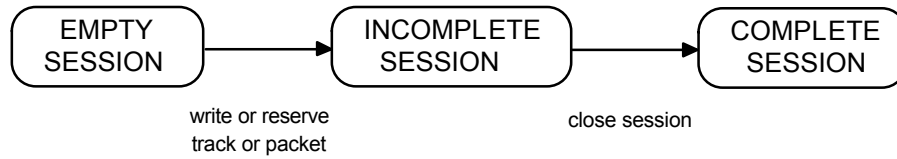

O.3.3. - Disc Status Definitions

O.3.3.1. - Static Disc Definitions

EMPTY DISC

INCOMPLETE DISC

COMPLETE DISC

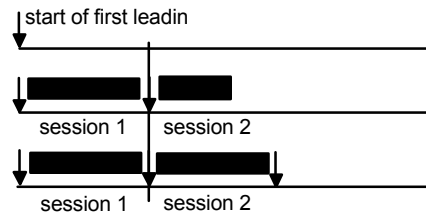

O.3.3.2. - Disc State Transitions

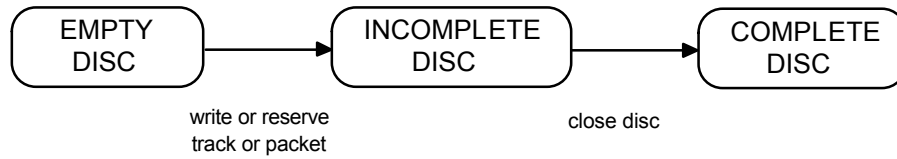

## O.3.4. - Test for Writable Disc

Determination of Disc Status prior to writing is described in Figure O.2 below.

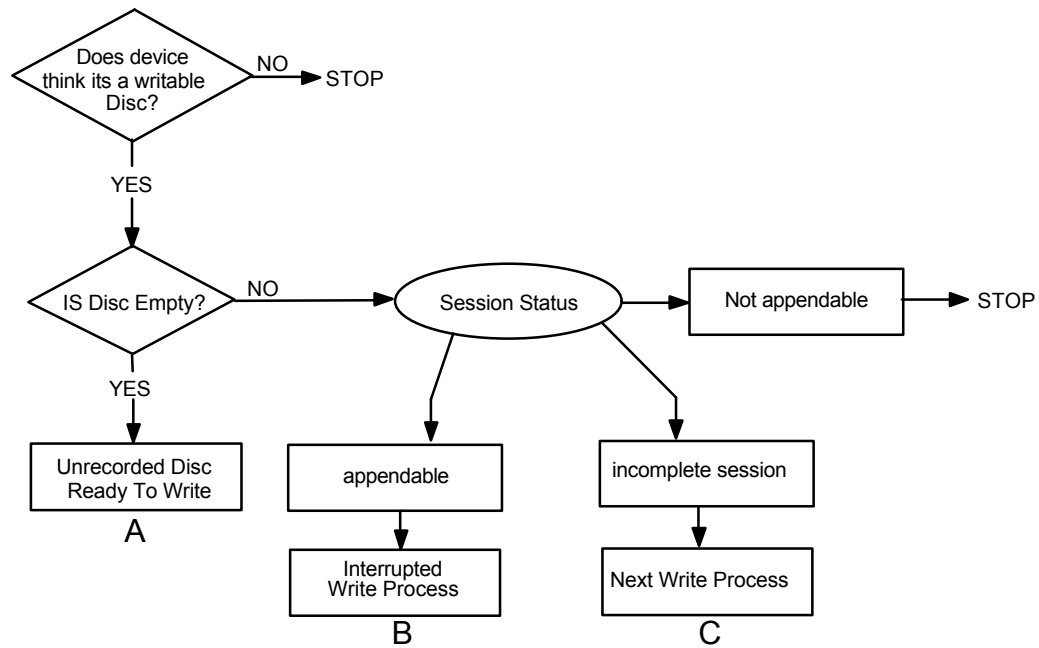

Figure O.2 - Test for Writable CD-R Disc

If the status indicates a blank disc the WRITE process proceeds to the execution of the WRITE operation (point A). If the status is determined to be a disc that has been written to but not full the process is to check for a complete session and proceed to the next write process (C), or to an interrupted write operation(B). Figure O.3 defines the write process once the status of the disc is determined.

O.4. - Write Process

The write process, described in Figure O.3, defines the various write processes that may be performed on a recordable CD. Entries into this process is at points A, B, and C. These points are described in other sub-clauses in this annex.

The write process includes incremental (interrupted) write, disc at once write (uninterrupted), track at once, and session at once writes.

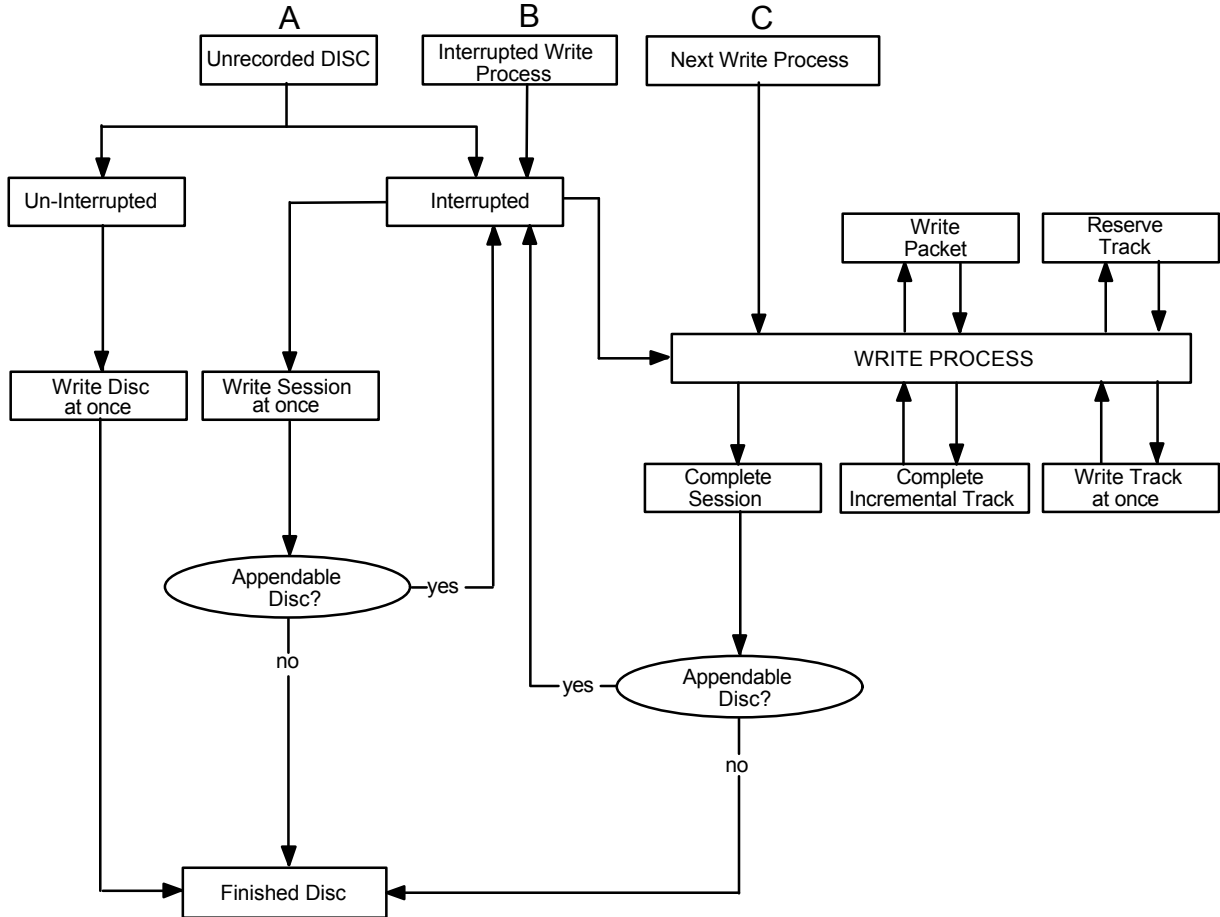

Figure O.3 - Overall Write Process

### O.5. - Empty Disc

The assumptions made by the initiator is that the disc inserted is a CD-R disc and that the device can detect the absent of EFM on the discs.

The basic primitives to accomplish this function are, 1) READ TOC, 2) READ PMA, 3) Read Main Channel Data based on ATIP address.

The process flow is shown in Figure O.4 for determining if a disc is blank and therefore capable of being written.

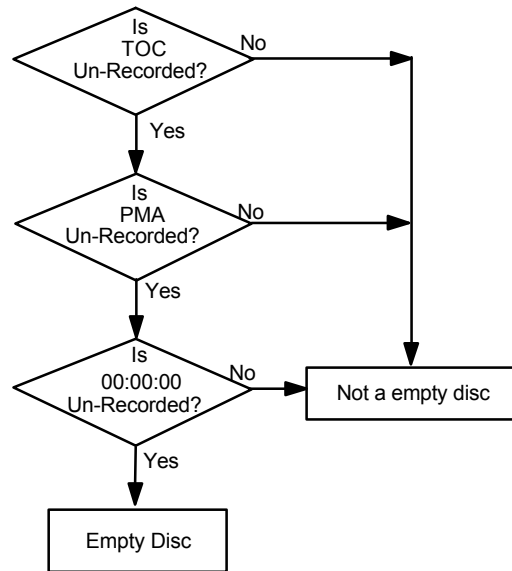

Figure O.4 - Blank Disc

## O.6. - Session Status

When testing for a writable disc, the initiator must test for incomplete sessions if the disc inserted has some recording already implemented. The process for determining if the disc has an incomplete session on it, is the disc able to have information appended to it, or is not appendable. Refer to Figure O.5 below for the method for determining contents of disc.

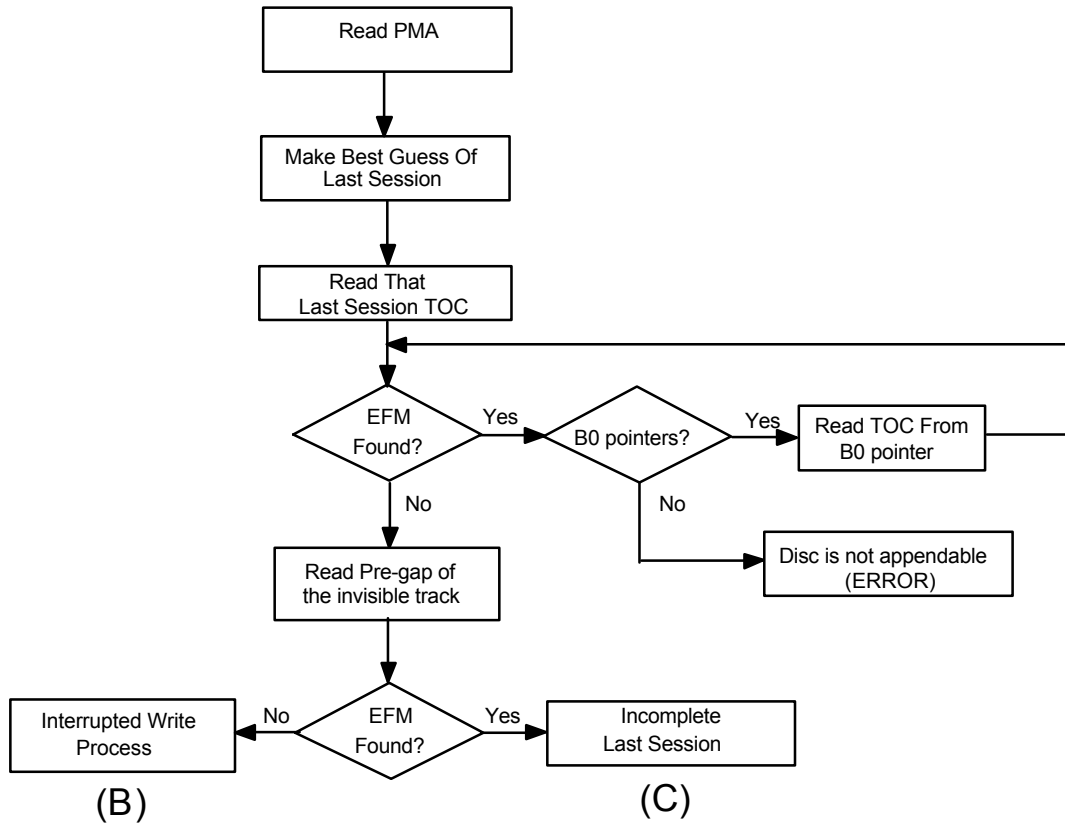

Figure O.5 - Session Status

Sectors that contain Sub Q Mode 0 should be considered as no EFM.

Points B and C are entries to the overall write process once the content of the disc is determined.

O.7. - RESERVE TRACK

For multiple session discs or recorders the capability to RESERVE Tracks and then return to record them is essential. The process to reserve a track is described in Figure O.6 below.

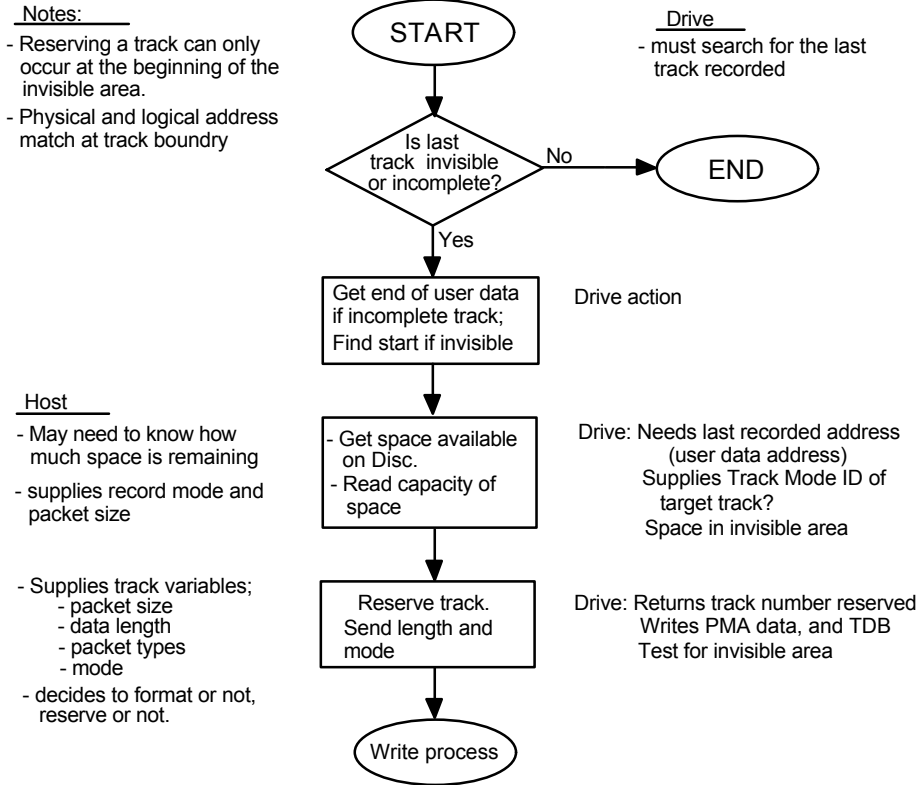

Figure O.6 - RESERVE TRACK



## O.8. - Write a Track

## Track at Once

1. Set the Write Parameters mode page:
  - a) Set the Write Type to "Track"
  - b) Set the Media Catalog Number if desired.
  - c) Set the ISRC if desired.
  - d) Set the Mode/Control.
  - e) Set the Open Next Session Pointer bit as appropriate.

Note: Setting this bit now removes the need to rewrite this mode page when the session is closed with a Close Track/Session command.

- f) Set the desired block size (2048-2448 bytes)
2. Use the Read Track Info command to get the block number of the first data block.

Note: This address reflects the next writable address after the drive writes the pre-gap.
3. Use the Write command to send blocks of data. The drive generates necessary information - header, Q sub-channel and ECC as appropriate and indicated by the block size.

Each subsequent write has an LBA specified that is n higher than the previous write command, where n is the number of blocks specified in the previous write command. An underrun may be indicated if the drive reports that this LBA is invalid.
4. After all data has been sent, the drive writes the run-out and link blocks.

Note: The end of data can be determined by an underrun, a Synchronize Cache command, or a Close Track/Session command.
5. Repeat as desired.

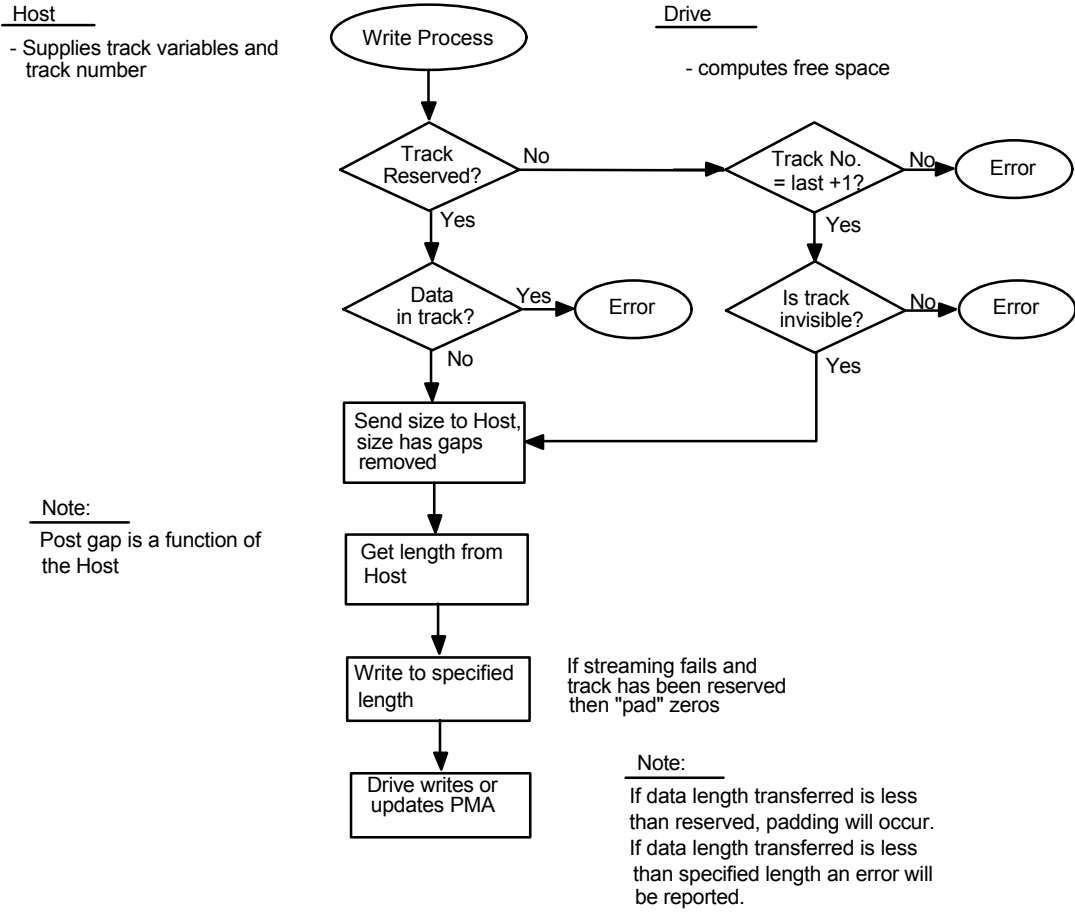

Figure O.7 - Write Track at Once

## O.9. - Write a Packet

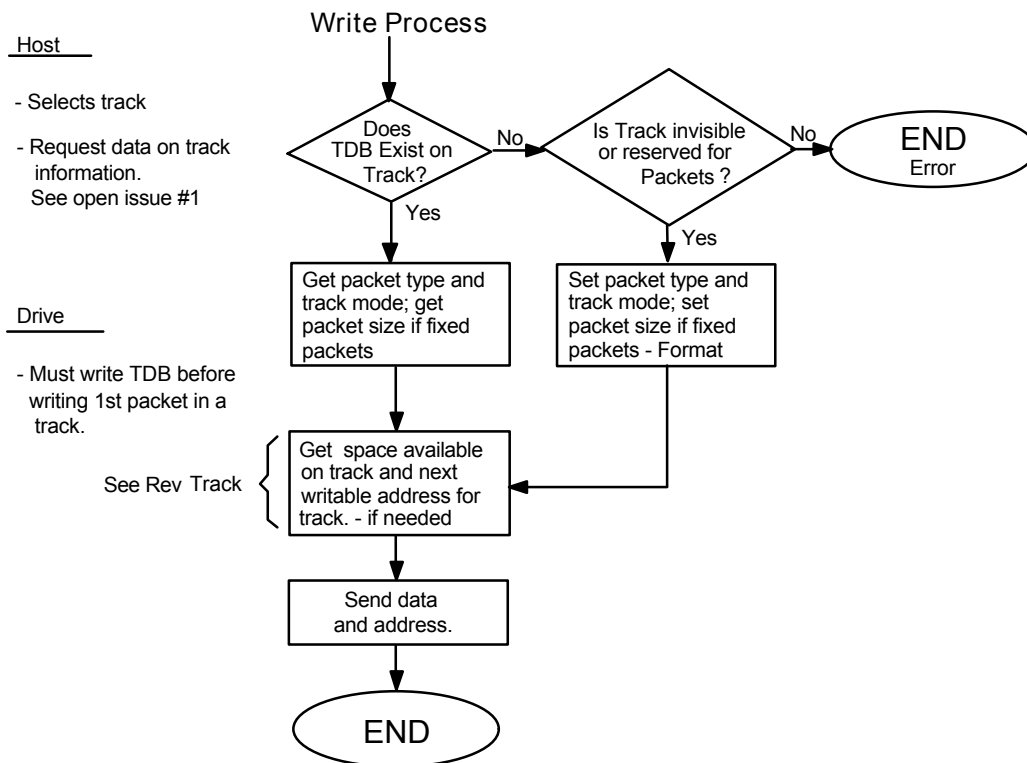

Figure O.8 - Write Packet

## Write Packet

- Set the Write Parameters mode page:
  - Read the Write Parameters Mode Page.
  - Set the Write Type to Packet.
  - Set the Media Catalog Number if desired.
  - Set the ISRC if desired.
  - Set the Mode/Control.
  - Set the packet type.
  - Set the packet size ( if packet type is fixed).
  - Set the Open Next Session Pointer bit as appropriate.

Note: Setting this bit now removes the need to rewrite this mode page when before the session is close with a Close Track/Session command.

- Set the desired block size (2048 - 2448 bytes).
- Read track information may be used at any time to obtain the next writable address. Note that the next writable address is somewhat dynamic; while streaming is in progress, the next writable address increments with each write command issued by the number of requested blocks. If streaming is interrupted, the next writable address will be seven blocks larger (in variable packet mode) due to the link area automatically produced.

It is possible to obtain a next writeable address that is not valid when the next write is attempted. This will occur if streaming is lost between the read track information command and the following write. In this case, the device detects the error by the (now) invalid LBA and return a check condition status (ILLEGAL ADDRESS).

The initiator may force the underrun condition at any time by issuing a SYNCHRONIZE CACHE command. The READ TRACK INFO command will then return a next writable address that is after the link area.

3. Use the Write command to send blocks of data. The drive generates necessary information - header, and ECC as appropriate and indicated by the block size. Q sub-channel is always generated by the drive.

To write a single variable packet with multiple WRITE commands, each subsequent write has an LBA specified that is  $n$  higher than the previous write command, where  $n$  is the number of blocks specified in the previous write command. An underrun may be indicated if this LBA is invalid.

To begin a new packet, the WRITE command has an LBA specified that is  $(n+7)$  higher than the previous write command, where  $n$  is the number of blocks specified in the previous write command.

4. After each packet has been sent, the drive writes the run-out and link blocks.  
Note: The end of data can be determined by an underrun, a Synchronize Cache command, or a Close Track/Session command.
5. Repeat as desired.

O.10. - Complete Incremental Track

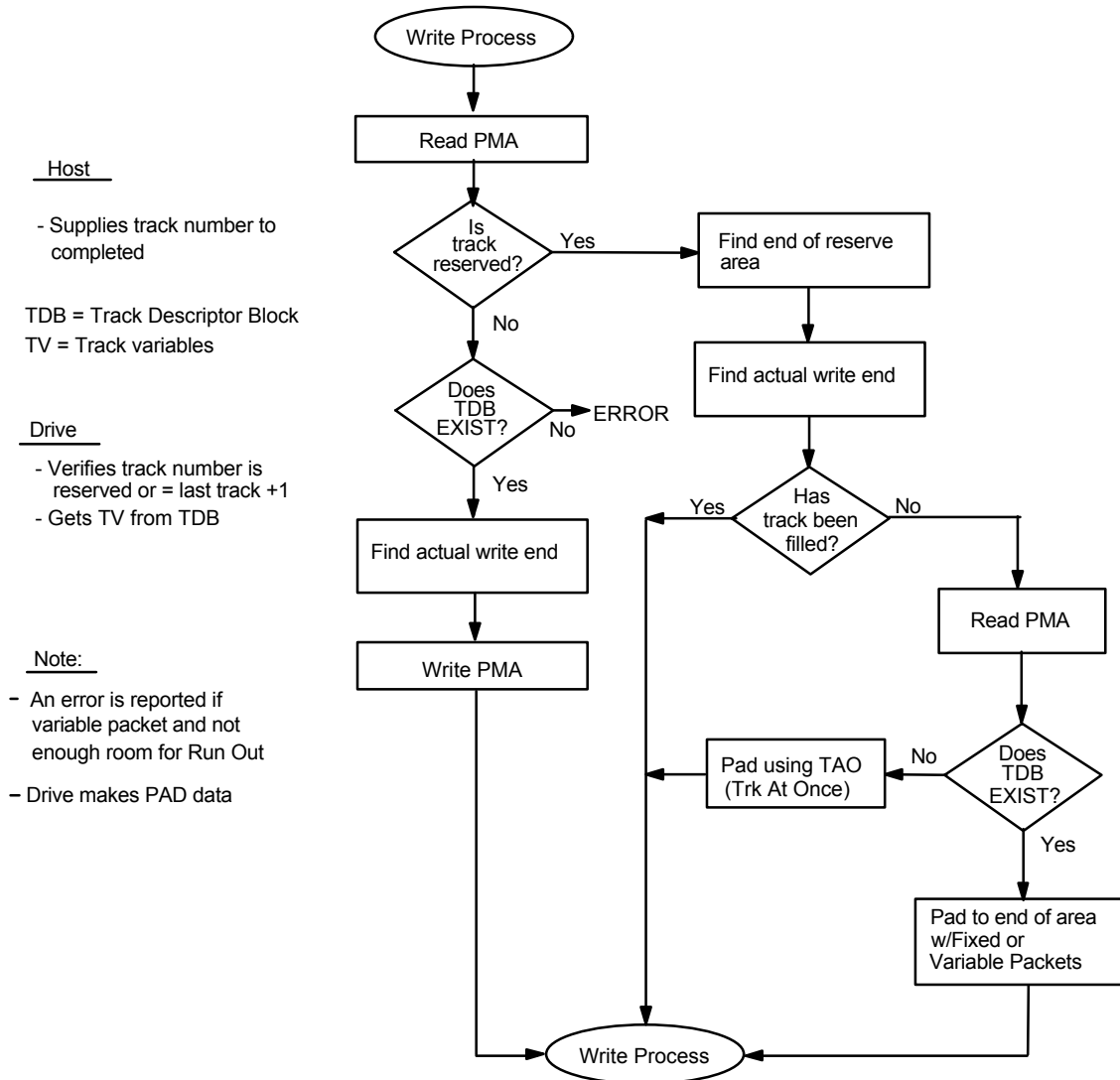

Figure O.9 - Complete Incremental Track

## O.11. - Write Raw

## Raw

1. Send the Write Parameters mode page with the Write Type set to "Raw." If the block is not Data Block Type of 1, 2 or 3, fill in the remainder of the fields as appropriate.
2. Use the Read Track Info command to get the block number of the lead-in. The number may be negative if this is the first session on the disc and the block is Data Block Type of 1, 2 or 3.
3. Use the Write command to send blocks of data.

If the block size is Data Block Type of 1, 2 or 3, each block of data includes both data and sub-channel information. Mode information for the link and run-in blocks is taken from the first data block. Q sub-channel position information is automatically generated by the drive for the link and run-in blocks.

Each subsequent write has an LBA specified that is n higher than the previous write command, where n is the number of blocks specified in the previous write command. An underrun may be indicated if the drive reports that this LBA is invalid.

4. After all data has been sent, the drive writes the link block. The drive should not generate run-in and run-out blocks (main and sub-channel 1 data) but shall generate and record the link block.
5. Repeat as desired.

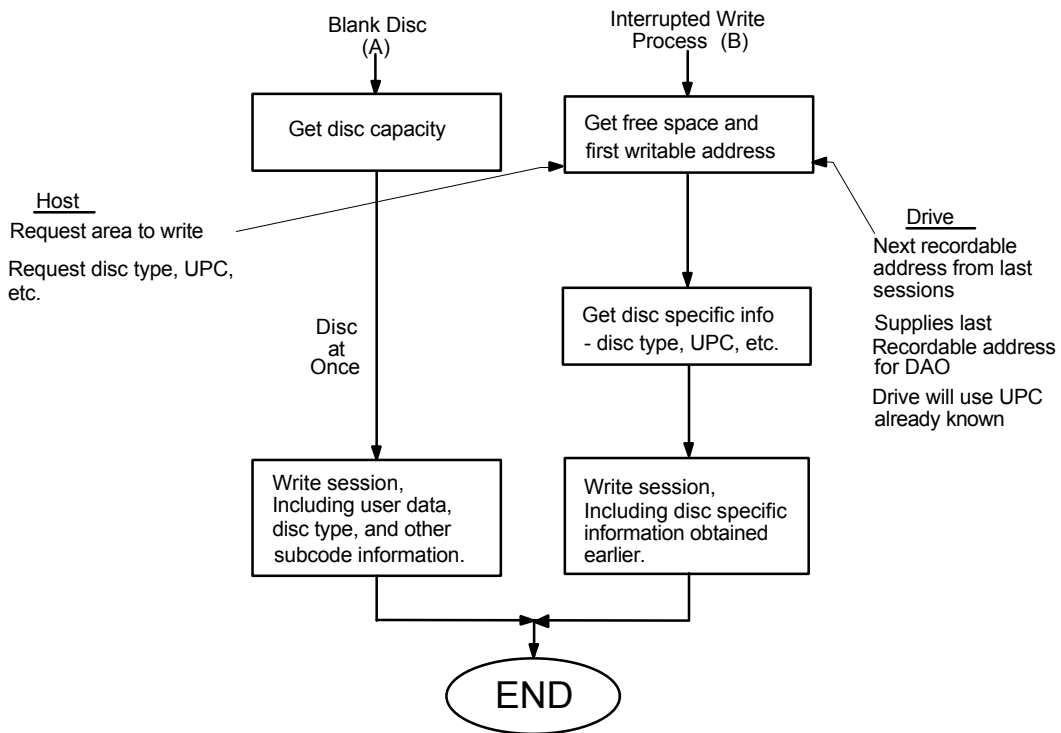

Figure O.10 - Write Session At Once

## O.12. - Complete Session

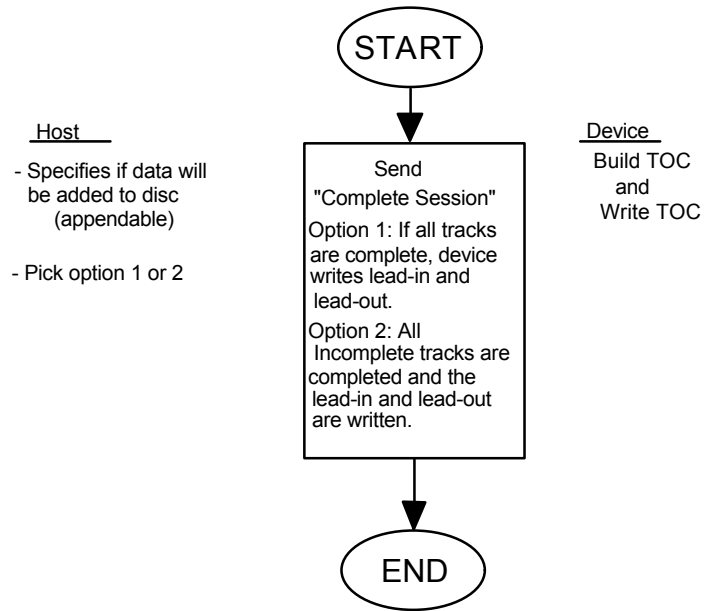

Figure O.11 - Complete Session

## Annex P - SAMPLES OF CUE SHEETS (Informative)

Table P 1 - Session At Once Cue sheet Sample 1 (CD-DA)

CONT / ADR (HEX)	TNO (HEX)	INDEX (HEX)	DATA FORM (HEX)	SCMS (HEX)	ABSOLUTE TIME (HEX)			Comments
					MIN	SEC	FRAME	
02	C1	C2	C3	C4	C5	C6	C7	CATALOG CODE
02	C8	C9	CA	CB	CC	CD	00	
01	00	00	00	00	00	00	00	
01	01	00	00	80	00	00	00	
01	01	01	00	80	00	02	00	
01	02	00	40	00	07	29	00	
01	02	01	40	00	07	31	00	ISRC CODE
03	03	11	12	13	14	15	16	
03	03	17	18	19	1A	1B	1C	
01	03	00	00	00	14	18	03	
01	03	01	00	00	14	20	03	
01	04	01	00	00	19	06	00	
01	05	00	00	00	27	37	00	
01	05	01	00	00	27	40	00	
01	06	00	00	00	38	53	74	
01	06	01	00	00	38	55	74	
01	06	02	00	00	45	12	42	
01	06	03	00	00	48	33	09	
01	06	04	00	00	52	47	59	
01	AA	01	00	00	56	37	46	

Control field reflects to lead-in Control Data type reflects follows:

TNO = 0: lead-in

TNO = 1-99: At track 1, Index 0 period is at least 2 seconds. (see track 1)  
 Index 0 period may be 0 seconds. (see track 4) for the second or higher track in the TOC,  
 Index 0 period may be divided into two parts. (see sample 7)

Each track: The CD standard requires the a track without an INDEX 0 must have a length greater than 4 seconds.

INDEX: Must start from 0 up to 99 Indexes (see track 6)  
 If no physical area of index = 0, ATIME of index = 0 and 1 must be the same. (see track 4)

TNO = AA: lead-out



Table P.2 - Cue Sheet Sample 2 (CD-ROM mode 1)

CONT / ADR (HEX)	TNO (HEX)	INDEX (HEX)	DATA FORM (HEX)	SCMS (HEX)	ABSOLUTE TIME (HEX)			Comments
					MIN	SEC	FRAME	
41	00	00	00	00	00	00	00	
41	01	00	10	00	00	00	00	
41	01	01	10	00	00	02	00	
41	02	00	10	00	07	29	00	
41	02	01	10	00	07	31	00	
41	03	00	10	00	14	18	03	
41	03	01	10	00	14	20	03	
41	AA	01	00	00	23	37	46	

Table P.3 - Cue sheet Sample 3 (CD-I)

CONT / ADR (HEX)	TNO (HEX)	INDEX (HEX)	DATA FORM (HEX)	SCMS (HEX)	ABSOLUTE TIME (HEX)			Comments
					MIN	SEC	FRAME	
41	00	00	00	00	00	00	00	
41	01	00	20	00	00	00	00	
41	01	01	20	00	00	02	00	
41	AA	01	00	00	56	37	46	

Table P.4 - Cue sheet Sample 4 (CD-ROM XA)

CONT / ADR (HEX)	TNO (HEX)	INDEX (HEX)	DATA FORM (HEX)	SCMS (HEX)	ABSOLUTE TIME (HEX)			Comments
					MIN	SEC	FRAME	
41	00	00	00	00	00	00	00	
41	01	00	21	00	00	00	00	
41	01	01	21	00	00	02	00	
41	02	00	21	00	07	29	00	
41	02	01	21	00	07	31	00	
41	AA	01	00	00	14	37	46	

Table P.5 - Cue sheet Sample 5 (CD-ROM mix mode)

CONT / ADR (HEX)	TNO (HEX)	INDEX (HEX)	DATA FORM (HEX)	SCMS (HEX)	ABSOLUTE TIME (HEX)			Comments
					MIN	SEC	FRAME	
41	00	00	00	00	00	00	00	
41	01	00	12	00	00	00	00	
41	01	01	12	00	00	02	00	
01	02	00	00	00	05	00	00	
01	02	01	00	00	05	02	00	
01	AA	01	00	00	10	00	00	

Table P.6 - Cue sheet Sample 6 (CDDA start track = 5)

CONT /ADR (HEX)	TNO (HEX)	INDE X (HEX)	DATA FORM (HEX)	SCMS (HEX)	ABSOLUTE TIME (HEX)			Comments
					MIN	SEC	FRAM E	
01	00	00	00	00	00	00	00	
01	05	00	00	80	00	00	00	
01	05	01	00	80	00	02	00	
01	06	00	00	80	05	00	00	
01	06	01	00	80	05	02	00	
01	07	00	00	80	08	00	00	
01	07	01	00	80	08	02	00	
01	AA	01	00	00	10	00	00	