

## Speech Recognition Microcontroller

### GENERAL DESCRIPTION

The RSC-300/364, from the Interactive Speech™ family of products, is an 8-bit microcontroller designed specifically for speech applications in consumer electronic products. The RSC-300/364 is a single chip solution that combines the flexibility of a microcontroller with advanced speech technology, including high-quality speech recognition, speech and music synthesis, speaker verification, and voice record and playback. Products can use one or all of the RSC-300/364 features in a single application.

The RSC-300/364 supports Sensory Speech™ 6, the latest speech recognition technology from Sensory, which includes a number of new techniques that significantly improve recognition performance over previous versions. Using a sophisticated neural network technology, on-chip speech recognition algorithms reach an accuracy of greater than 97% for speaker-independent recognition and greater than 99% for speaker-dependent recognition.

In addition to the improved recognition performance, the RSC-300/364 provides further on-chip integration of features, including a preamplifier, multiplier, timer-2, and 2.5 Kbytes of RAM. A complete system may be built with few additional parts other than a battery, speaker, microphone, and a few resistors and capacitors. The RSC-300 is designed for ROM-less for applications that need more ROM space and consequently use off-chip memory.

### FEATURES

#### Full Range of Sensory Speech™ 6 Capabilities

- Speaker-independent speech recognition
- Speaker-dependent speech recognition
- High quality speech synthesis and sound effects
- Speaker verification
- Four-voice music synthesis
- Voice record & playback

#### Integrated Single-Chip Solution

- 4 MIPS 8-bit microcontroller
- On-chip A/D and D/A converters, and pre-amplifier
- 32kHz clock for time keeping
- Internal 64 Kbytes ROM; 2.5 Kbytes RAM
- Secondary Timer 2
- External memory bus: 16-bit Address, 8-bit Data
- 24x24 Multiplier for rapid recognition processing

#### Low Power Requirements

- 2.85 – 5.25V operation
- ~10mA operating current at 3V
- Power down mode; <5 µA standby current

### RSC-300/364 Block Diagram

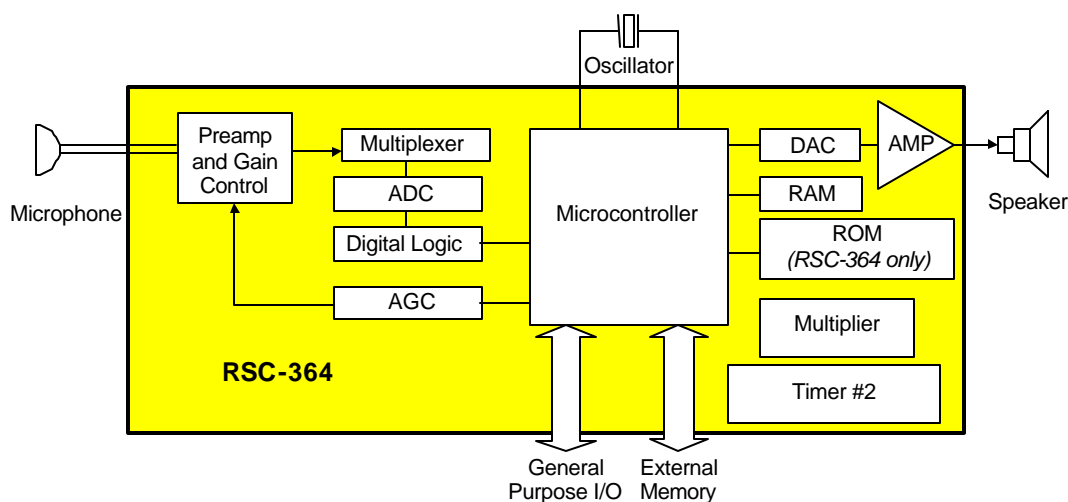

## RSC-300/364 OVERVIEW

The RSC-300/364 is a member of the Interactive Speech™ line of products from Sensory. It features a high-performance 8-bit microcontroller with on-chip A/D, D/A, preamplifier, RAM and ROM (RSC-364 only). The RSC-300/364 is designed to bring a high degree of integration and versatility into low-cost, power-sensitive toy applications.

Various functional units have been integrated onto the CPU core in order to reduce total system cost and increase system reliability without degrading system performance. The RSC-300/364 delivers 4 MIPS of integer performance at 14.32 MHz providing maximum performance at minimum cost.

The CPU core embedded in the RSC-300/364 is an 8-bit, variable-length-instruction, microcontroller. The instruction set is somewhat similar to the Zilog™ 78, and has a variety of addressing mode *mov* instructions. The RSC-300/364 processor avoids the limitations of dedicated A, B, and DPTR registers by having completely symmetrical source and destinations for all instructions. Of the 2.5 Kbytes of internal RAM, 2 Kbytes are organized as a Data Space, with 0.5K used for Register Space.

## SPEECH RECOGNITION

The RSC-300/364 uses a neural network to perform speaker-independent or speaker-dependent speech recognition. Speaker-dependent recognition requires external memory to store speech recognition information (e.g., SRAM, optional Serial EEPROM, Flash Memory). Speaker-independent recognition requires on-chip or off-chip ROM to store the words to be recognized. The RSC-300/364 has several additional speech recognition features as described below.

*Continuous listening* allows the chip to continuously listen for a specific word. With this feature a product can be used in a normal environment and only “activates” when a specific word, preceded by quiet, is spoken.

## SPEECH AND MUSIC SYNTHESIS

The RSC-300/364 provides high-quality speech synthesis by using a hybrid of a time-domain compression scheme that improves on conventional ADPCM and a customized reuse of sounds. Speech synthesis requires on-chip or off-chip ROM to store audio sounds for synthesis.

The RSC-300/364 provides high-quality, low-cost four-voice music synthesis which allows multiple, simultaneous instruments for harmonizing. The RSC-300/364 uses a MIDI-like system to generate music.

## RECORD AND PLAYBACK

The RSC-300/364 can perform audio record and playback at various compression levels depending on the quantity and quality of playback desired. Data rates of under 14,000 bits per second are achievable while maintaining very high quality reproduction. The RSC-300/364 also performs silence removal to improve sound quality and reduce memory requirements.

## SPEAKER VERIFICATION

The RSC-300/364 can also perform text-dependent speaker verification. After a speaker trains the chip on a specific word, the chip is able to identify whether that word is spoken by the original speaker, thus providing biometric security.

## POWER

The typical operating current is 10 mA operating at 14.32 MHz and 3V. Lowering clock frequency reduces power consumption, although speech recognition requires a 14.32 MHz clock. Standby current is <5µA in power down mode.

## RSC-300/364 Architecture Diagram

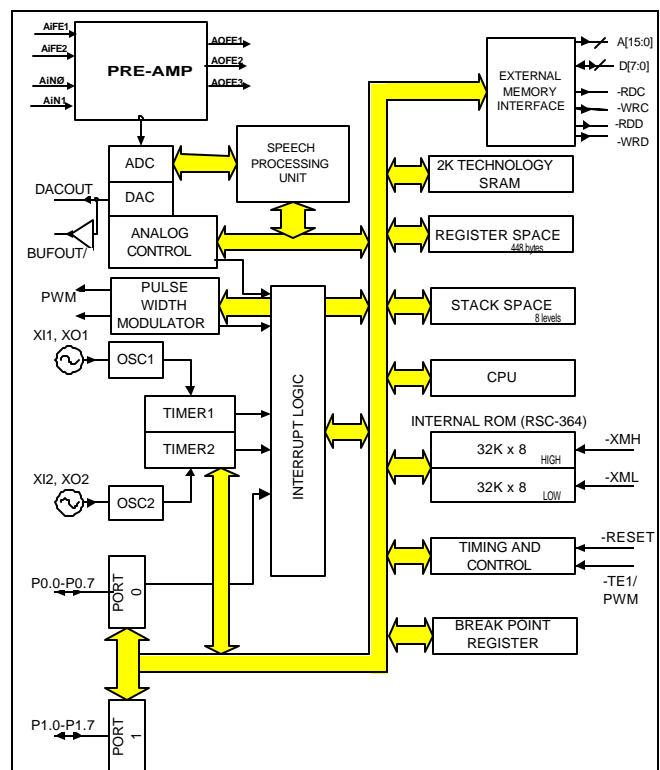

## RSC-300/364 ARCHITECTURE

The RSC-300/364 is a highly integrated device that combines:

- 8-bit microcontroller
- On-chip ROM (64 Kbytes, RSC-364 only) and RAM (2.5 Kbytes), and the ability to address off-chip RAM or ROM
- A/D converter and D/A converter
- Input amplifier and pulse width modulator

The RSC-300/364 has an external memory interface, with 16-bit addresses and 8-bit data buses, for accessing external memory. It also has an internal ROM (RSC-364 only) that can be enabled or disabled (partially or fully) by pin inputs (signals, -XMH, -XML).

Two bi-directional ports provide 16 general purpose I/O pins to communicate with external devices. The RSC-300/364 has a high frequency (14.32 MHz) oscillator as well as a low frequency (32,768 Hz) oscillator suitable for timekeeping applications. The processor clock can be selected from either source, with a selectable divider value. The device performs speech recognition when running at 14.32 MHz. The RSC-300/364 also supports programmable wait states to allow the use of slower external devices.

There are two programmable 8-bit counters / timers, one derived from each oscillator.

An external microphone passes an audio signal to the preamplifier and ADC (Analog-to-Digital Converter) to convert the incoming speech signal into digital data. The output audio signal of the RSC-300/364 is derived from a DAC (Digital-to-Analog Converter) or PWM (Pulse Width Modulator).

## USING THE RSC-300/364

Creating applications using the RSC-300/364 requires the development of electronic circuitry, software code, and speech/music data files. Software code for the RSC-300/364 can be developed by Sensory or by external programmers using the RSC-300/364 Development Kit. For more information about development tools and services, please contact Sensory. A typical product will require about \$0.30 - \$1.00 (in high volume) of additional components, in addition to the RSC-300/364.

The following sample circuit provides an example of how the RSC-300/364 might be used in a consumer electronic product.

## Sample Application Circuit (Die)

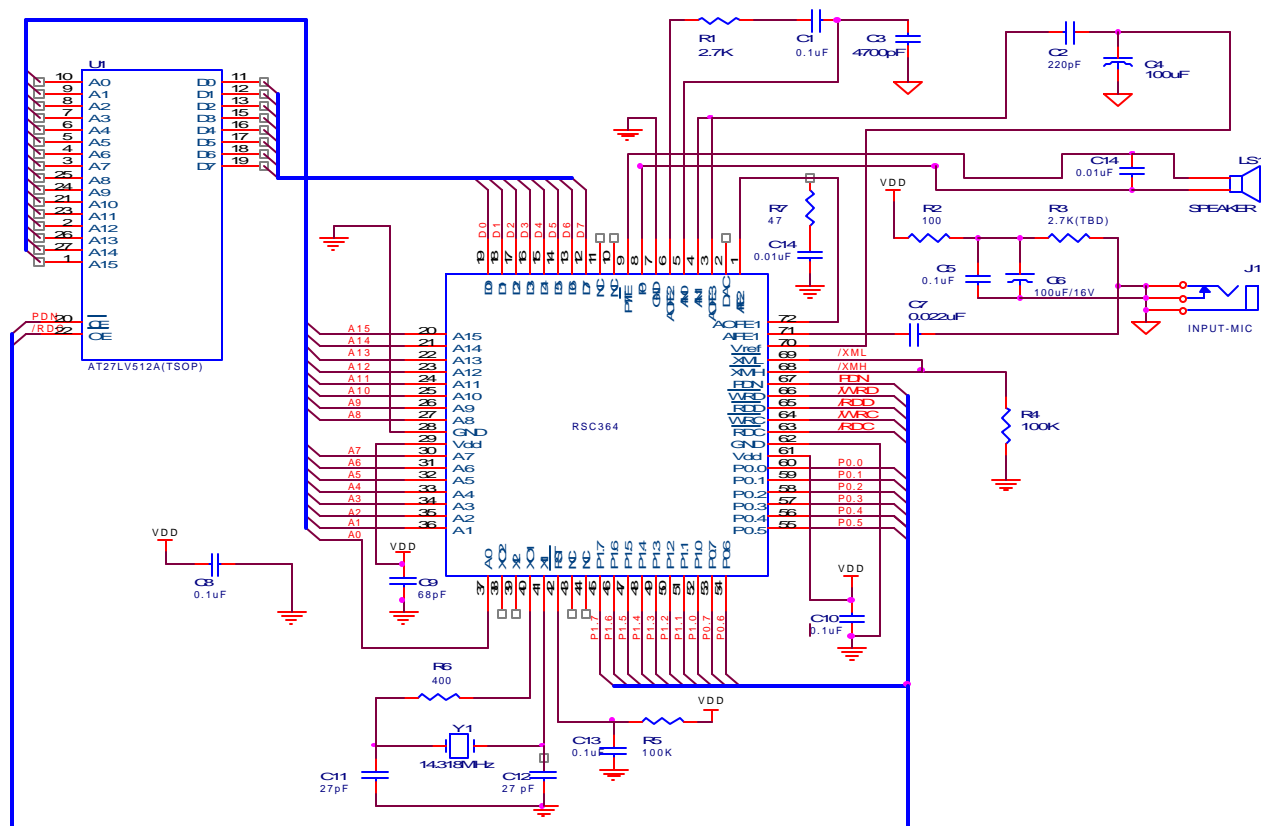

## RSC-300/364 INSTRUCTION SET

The instruction set for the RSC-300/364 has 54 instructions comprising 10 move, 7 rotate, 11 branch, 11 register arithmetic, 9 immediate arithmetic, and 6 miscellaneous instructions. All instructions are 3 bytes or fewer, and no instruction requires more than 10 clock cycles to execute.

## GENERAL PURPOSE I/O

The RSC-300/364 has 16 general purpose I/O pins (P0.0-P0.7, P1.0-P1.7). Each pin can be programmed as an input with weak pull-up (~150k $\Omega$  equivalent device); input with strong pull-up (~10k $\Omega$  equivalent device); input without pull-up, or as an output.

## EXTERNAL MEMORY

The RSC-300/364 includes an external memory interface that allows connection with memory devices for speaker-dependent speech recognition, audio record/playback, and extended durations of speech and music synthesis.

Separate data and address buses allow use of standard EPROMs, ROMs, SRAMs, and Flash memory with little or no additional decoding. Support for separate read and write signals for each external memory space further simplifies interfacing. The RSC-300/364 includes 8 data lines (D[7:0]) and 16 address lines (A[15:0]), and associated control signals for memory interfacing.

## OSCILLATORS

Two independent oscillators in the RSC-300/364 provide a high-frequency clock and a 32kHz time-keeping clock. Both oscillators work with an external crystal, a ceramic resonator or LC. The oscillator characteristics are:

Oscillator #1:	Pins XI1, XO1 14.32 MHz
Oscillator #2	Pins XI2 and XO2 32768 Hz

## CLOCK

The RSC-300/364 uses a fully static core – the processor can be stopped (by removing the clock source) and restarted without causing a reset or losing contents of internal registers. Static operation is guaranteed from DC to 14.32 MHz.

Typically the processor clock runs from a 14.32 MHz crystal with no divisor and one wait state. This creates internal RAM cycles of 70 nsec duration and internal ROM (RSC-364 only) or external cycles of 140 nsec

duration. Careful design may allow operation with memories having access times as slow as 120 nsec.

## TIMERS/COUNTERS

The two independent oscillators of the RSC-300/364 provide counts to two internal timers. Each of the two timers consists of an 8-bit reload value register and an 8-bit up-counter. The reload register is readable and writable by the processor.

## INTERRUPTS

The RSC-300/364 allows for five interrupt sources, as selected by software. Each has its own mask bit and request bit in the IMR and IRQ registers respectively. The following events can generate interrupts:

- Positive edge on Port 0, bit 0
- Overflow of Timer 1
- Overflow of Timer 2
- Sensory reserved functions
- Completion of PWM sample period

## PREAMPLIFIER

The on-chip preamplifier circuit consists of three stages with a maximum overall gain of about 500. The amplifier includes a Vref input that is used to set the amplifier center voltages and must be driven by a low impedance voltage supplied by an external source. The signal inputs of all stages have an 80 K $\Omega$  input impedance to the Vref pad. In a typical design, AOFE1 would be directly coupled to AIFE2, and AOFE2 would be capacitively coupled to AIN0 through an RC lowpass filter to remove DC offset and digital noise. AOFE3 would be bypassed to Vref with a small (220pF) capacitor for additional noise suppression.

## ANALOG OUTPUT

The RSC-300/364 offers two separate options for analog output. The DAC (Digital to Analog Converter) output provides a general purpose 10-bit analog output that may be used for speech output (with the inclusion of an audio amplifier), or other purposes requiring an analog waveform. For speech applications that require driving a small speaker, the PWM (Pulse-Width Modulator) output can be used instead of the DAC output. The PWM output can directly drive a 32 ohm speaker.

## PACKAGING

The RSC-300/364 can be purchased as unpackaged die or a 64 pin TQFP package.

## DIE BOND PAD AND QFP PIN DESCRIPTIONS

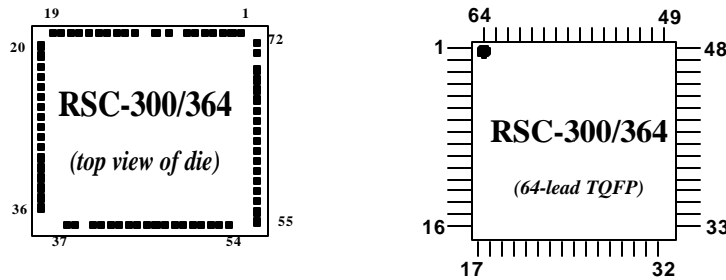

Name	Die Pad	QFP Pin	Description	I/O
A[15:0]	20-27, 30-37	1-8, 11-18	External Memory Address Bus	O
AIN0	5	52	Analog In, low gain. (range AGND to AVDD/2.)	I
AIN1	4	51	Analog In, hi gain (8X input amplitude of AIN0, same range)	I
AOFE1	72	49	Output of 1 <sup>st</sup> stage of preamplifier	O
AOFE2	6	53	Output of 2 <sup>nd</sup> stage of preamplifier	O
AOFE3	3	51	Output of 3 <sup>rd</sup> stage of preamplifier	O
AIFE1	71	48	Input of 1 <sup>st</sup> stage of preamplifier	I
AIFE2	1	49	Input of 2 <sup>nd</sup> stage of preamplifier	I
NC	10,11,43,44		Not Connected	-
PWM0	8	55	Pulse Width Modulator Output0	O
DACOUT	2	50	Analog Output (unbuffered).	O
D[7:0]	12-19	57-64	External Data Bus	I/O
Vss	7,28,62	9, 39,54	Vss	-
PDN	67	44	Power Down. Active high when powered down.	O
P1[7:0], P0[7:0]	43-52,53-60	22-29, 30-37	General Purpose Port I/O. Pin P0.0 can act as an external interrupt input. All I/O pins can act as "wake up" inputs.	I/O
/RDC	63	40	External Code Read Strobe	O
/RDD	65	42	External Data Read Strobe	O
/RESET	42	21	Reset	I
/TE1 or PWM1	9	56	Test Mode <i>or</i> Pulse Width Modulator Output1 (multiplexed)	I <i>or</i> O
VREF	70	47	Reference Voltage = Vdd/2 or Vdd/4. Depends on software	-
V <sub>DD</sub>	29,61	10,38	Supply Voltage	-
/WRC	64	41	External Code Write Strobe	O
/WRD	66	43	External Data Write Strobe	O
/XMH	68	45	External Hi-memory enable (low active)	I
/XML	69	46	External Low-memory enable (low active)	I
XO1	40	19	Oscillator 1 output (high frequency)	O
XI1	41	20	Oscillator 1 input	I
XO2	38	NA	Oscillator 2 output (32768 Hz)	O
XI2	39	NA	Oscillator 2 input	I

Note: Substrate should be connected to VSS

**DC CHARACTERISTICS**(T<sub>O</sub> = 0°C to +70°C, V<sub>DD</sub> = 2.85V – 5.25V )

SYMBOL	PARAMETER	MIN	TYP	MAX	UNITS	TEST CONDITIONS
V <sub>IL</sub>	Input Low Voltage	-0.1		0.75	V	
V <sub>IH(Vcc&lt;3.6)</sub>	Input High Voltage	0.8*Vdd		Vdd+0.3	V	
V <sub>IH(Vcc&gt;3.6)</sub>	Input High Voltage	3.0		Vdd+0.3	V	
V <sub>OL</sub>	Output Low Voltage		0.3	0.1*Vdd	V	I <sub>OL</sub> = 2 mA
V <sub>OH</sub>	Output High Voltage (I/O Pins)	0.8*Vdd	0.9*Vdd		V	I <sub>OL</sub> = -2 mA
I <sub>IL</sub>	Logical 0 Input Current		<1	10	uA	V <sub>ss</sub> < V <sub>pin</sub> < V <sub>dd</sub>
I <sub>DD1</sub>	Supply Current, Active		10	20	mA	Hi-Z Outputs
I <sub>DD3</sub>	Supply Current, Powerdown		1	10	uA	Hi-Z Outputs
R <sub>pu</sub>	Pull-up resistance P0.0-P1.7					
	I/O Pins	5,80, Hi-Z	4.5,200, Hi-Z		kΩ	Selected with software
	/XML,/XMH		200		kΩ	Fixed

**A.C. CHARACTERISTICS (EXTERNAL MEMORY ACCESSES)**(T<sub>O</sub> = 0°C to +70°C, V<sub>DD</sub> = 5V; load capacitance for outputs = 80 pF; Osc=14.32 MHz)

SYMBOL	PARAMETER	CPU=osc/1, 1 WS		CPU=osc/2, 0WS		UNITS
		MIN	MAX	MIN	MAX	
1/TCL1	Processor Clock frequency		14.32		7.16	MHz
TRLRH	-RDC (-RDD) Pulse Width		140		140	ns
TRLAV	-RDC (-RDD) Low to Address valid		5		5	ns
TALRAX	Address hold after -RDC (-RDD)		0		0	ns
TRAVDV	Address valid to Valid Data In		135		135	ns
TRHDX	Data Hold after -RDC (-RDD)	0		0		ns
TWLWH	-WRC (-WRD) Pulse Width		140		140	ns
TAVWL	Address Valid to -WRC (-WRD)	35		70		ns
TALWAX	Address Hold after -WRC (-WRD)	35		70		ns
TWDVAV	Write Data Valid to Address Valid		5		5	ns
TWHQX	Data Hold after -WRC (-WRD)	35		70		ns

### TIMING DIAGRAMS

Note that the -RDC signal does not necessarily pulse for every read from code space, but may stay low for multiple cycles.

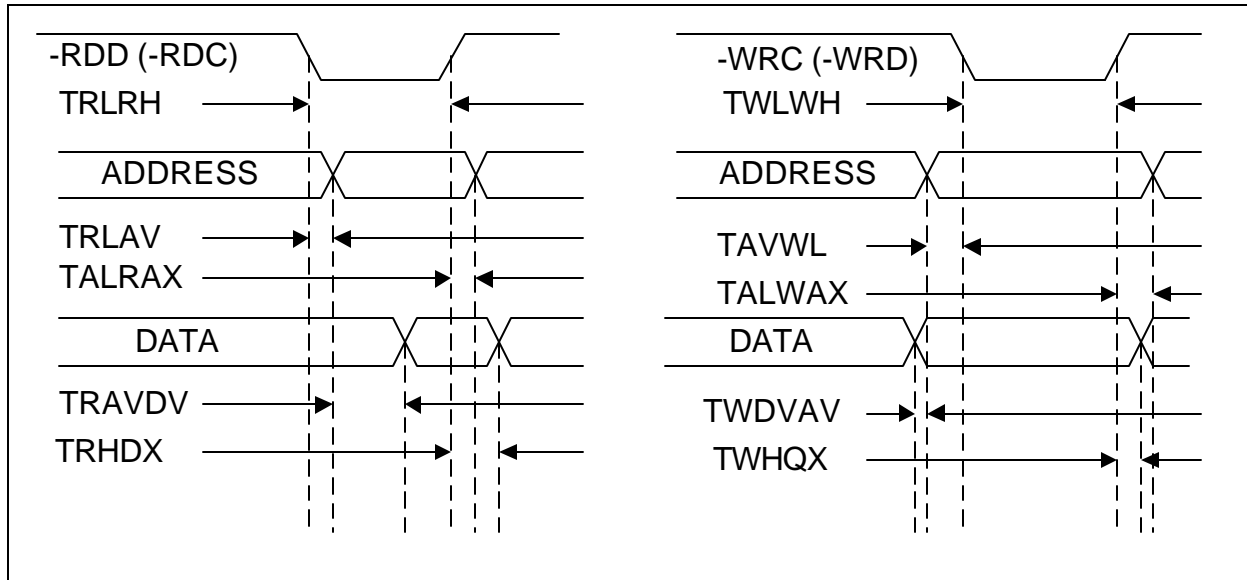

External Read Timing

External Write Timing

### ABSOLUTE MAXIMUM RATINGS

Any pin to GND	-0.1V to +6.5V
Operating temperature (T <sub>o</sub> )	0°C to +70°C
Soldering temperature	260°C for 10 sec
Power dissipation	1 W
Operating Conditions	0°C to +70°C; V <sub>DD</sub> =2.85 - 5.25V V <sub>SS</sub> =0V

**WARNING:** *Stressing the RSC-300/364 beyond the “Absolute Maximum Ratings” may cause permanent damage. These are stress ratings only. Operation beyond the “Operating Conditions” is not recommended and extended exposure beyond the “Operating Conditions” may affect device reliability.*

### ORDERING INFORMATION

Part	Shipping P/N	Marketing P/N	Description
RSC-300 Die	65-0087	C300XS1P	Tested, Singulated RSC-300 die in waffle pack
RSC-300B Die	65-0098	C30BXS1P	Tested, Singulated RSC-300B die in waffle pack
RSC-300 QFP	65-0111	C300XT1V	RSC-300 64 pin 10 x 10 x 1.0 mm TQFP
RSC-364 Die	(ROM specific)	C364XS1P	Tested, Singulated RSC-364 die in waffle pack
RSC-364 QFP	(ROM specific)	C364XT1V	RSC-364 64 pin 10 x 10 x 1.0 mm TQFP

## THE INTERACTIVE SPEECH™ PRODUCT LINE

The Interactive Speech line of ICs and software was developed to “bring life to products” through advanced speech recognition and audio technology. The Interactive Speech Product Line was designed for consumer telephony products and cost-sensitive consumer electronic applications such as home electronics, personal security, and personal communication. The product line includes award-winning RSC-series general-purpose microcontrollers and tools plus a line of easy-to-implement chips that can be pin-configured or controlled by an external host microcontroller. Sensory’s software technologies run on a variety of microcontrollers and DSPs.

### RSC Microcontrollers and Tools

The RSC family of microcontrollers (RSC-300/364) are low-cost 8-bit microcontrollers designed for use in consumer electronics. All members of the RSC family are fully integrated and include A/D, pre-amplifier, D/A, ROM (RSC-364), and RAM circuitry. The RSC family can perform a full range of speech/audio functions including speech recognition, speaker verification, speech and music synthesis, and voice record/playback. The family is supported with a complete suite of tools and development kits.



### Application Specific Standard Products (ASSPs)

**Voice Direct™ 364** provides inexpensive speaker-dependent speech recognition and speech synthesis. This easy-to-use, pin-configurable chip requires no custom programming and can recognize up to 60 trained words in slave mode, and 15 words in stand-alone mode. Ideal for speaker-dependent command and control of household consumer products, Voice Direct™ 364 is part of a complete product line that includes the IC, module, and Voice Direct 364 Speech Recognition Kit.

**Voice Dialer™ 364** delivers speech recognition technology that allows users to dial phone numbers by saying the name of the person they wish to call. Voice dialing and phone directory management through speech recognition can be easily integrated into existing products. This IC is designed for use as a slave chip controlled by an external host processor.

**Voice Extreme™** simplifies the creation of fully custom speech-enabled products by offering developers the capability of programming the chip in a high-level C-like language. Program code, speech data, and even record and playback information can be stored on a single off-chip Flash memory. Based on Sensory’s RSC-364 speech processor, Voice Extreme includes a highly efficient on-chip code interpreter, and is supported by a comprehensive suite of low-cost development tools..

### Software and Technology

**Voice Activation™** micro footprint software provides advanced speech technology on a variety of microcontroller and DSP platforms. A flexible design with a broad range of technologies allows manufacturers to easily integrate speech functionality into consumer electronic products.

**Fluent Speech™** small footprint software recognizes up to 50,000 words; offers Animated Speech with the ability to automate enunciation and articulation; performs text-to-speech synthesis in either male or female voices; provides noise and echo cancellation, performs wordspotting for natural language usage; offers telephone barge-in; and provides continuous digit recognition.

### IMPORTANT NOTICES

Sensory reserves the right to make changes to or to discontinue any product or service identified in this publication at any time without notice in order to improve design and supply the best possible product. Sensory does not assume responsibility for use of any circuitry other than circuitry entirely embodied in a Sensory product. Information contained herein is provided gratuitously and without liability to any user. Reasonable efforts have been made to verify the accuracy of this information but no guarantee whatsoever is given as to the accuracy or as to its applicability to particular uses.

Applications described in this data sheet are for illustrative purposes only, and Sensory makes no warranties or representations that the RSC series of products will be suitable for such applications. In every instance, it must be the responsibility of the user to determine the suitability of the products for each application. Sensory products are not authorized for use as critical components in life support devices or systems.

Sensory conveys no license or title, either expressed or implied, under any patent, copyright, or mask work right to the RSC series of products, and Sensory makes balance between recognition and synthesis no warranties or representations that the RSC series of products are free from patent, copyright, or mask work right infringement, unless otherwise specified. Nothing contained herein shall be construed as a recommendation to use any product in violation of existing patents or other rights of third parties. The sale of any Sensory product is subject to all Sensory Terms and Conditions of Sales and Sales Policies.



S E N S O R Y

[www.VoiceActivation.com](http://www.VoiceActivation.com)

1991 Russell Ave.  
Santa Clara, CA 95054  
TEL: (408) 327-9000  
FAX: (408) 727-4748

© 2001 SENSORY, INC.  
ALL RIGHTS RESERVED

### IMPORTANT NOTICE

Reasonable efforts have been made to verify the accuracy of information contained herein, however no guarantee can be made of accuracy or applicability. Sensory reserves the right to change any specification or description contained herein.

Sensory is registered by the U.S. Patent and Trademark Office. All other trademarks or registered trademarks are the property of their respective owners.